



FEDERAL SIGNAL
Safety and Security Systems

Yagi and Omni Antennas

Installation Manual

Limited Warranty

This product is subject to and covered by a limited warranty, a copy of which can be found at www.fedsig.com/SSG-Warranty. A copy of this limited warranty can also be obtained by written request to Federal Signal Corporation, 2645 Federal Signal Drive, University Park, IL 60484, email to info@fedsig.com or call +1 708-534-3400.

This limited warranty is in lieu of all other warranties, express or implied, contractual or statutory, including, but not limited to the warranty of merchantability, warranty of fitness for a particular purpose and any warranty against failure of its essential purpose.



FEDERAL SIGNAL Safety and Security Systems

2645 Federal Signal Drive
University Park, Illinois 60484-3617

www.fedsig.com

Customer Support 800-548-7229 • +1 708 534-3400
Technical Support 800-524-3021 • +1 708 534-3400

All products indicated are trademarks of Federal Signal Corporation.
All other product names or trademarks are properties of their respective owners.

Contents

Safety Messages	4
General Description	6
Introduction	6
Planning your Antenna System.....	6
Installing the Antennas.....	6
Installing the Yagi Antenna	7
Yagi Antenna Pre-Assembly Instruction.....	7
Final VSWR Tuning.....	8
Mount Yagi Antenna	8
Installing the Omni Antenna	9
Getting Service	12

Figures

Figure 1 Yagi Antenna Installation Example	10
Figure 2 Omni Antenna Installation Example	10
Figure 3 Antenna Grounding	11
Figure 4 Typical Antenna Pole Mount (AMP-P) Installation	13
Figure 5 Typical Antenna Wall Mount (AMP-W) Installation	14

Safety Messages

⚠ WARNING

It is important to follow all instructions shipped with this product. This device is to be installed by trained personnel who are thoroughly familiar with the country electric codes and will follow these guidelines as well as local codes.

Listed below are important safety instructions and precautions you should follow:

Important Notice

Federal Signal reserves the right to make changes to devices and specifications detailed in the manual at any time in order to improve reliability, function or design. The information in this manual has been carefully checked and is believed to be accurate; however, no responsibility is assumed for any inaccuracies.

Publications

Federal Signal recommends the following publications from the Federal Emergency Management Agency for assistance with planning an outdoor warning system:

- The “Outdoor Warning Guide” (CPG 1-17)
- “Civil Preparedness, Principles of Warning” (CPG 1-14)
- FEMA-REP-1, Appendix 3 (Nuclear Plant Guideline)
- FEMA-REP-10 (Nuclear Plant Guideline).

Planning

- If suitable warning equipment is not selected, the installation site for the siren is not selected properly or the siren is not installed properly, it may not produce the intended optimum audible warning. Follow Federal Emergency Management Agency (FEMA) recommendations.
- If sirens are not activated in a timely manner when an emergency condition exists, they cannot provide the intended audible warning. It is imperative that knowledgeable people, who are provided with the necessary information, are available at all times to authorize the activation of the sirens.
- When sirens are used out of doors, people indoors may not be able to hear the warning signals. Separate warning devices or procedures may be needed to effectively warn people indoors.
- The sound output of sirens is capable of causing permanent hearing damage. To prevent excessive exposure, carefully plan siren placement, post warnings, and restrict access to areas near sirens.
- Activating the sirens may not result in people taking the desired actions if those to be warned are not properly trained about the meaning of siren sounds. Siren users should follow FEMA recommendations and instruct those to be warned of correct actions to be taken.

- After installation, service, or maintenance, test the siren system to confirm that it is operating properly. Test the system regularly to confirm that it will be operational in an emergency.
- If future service and operating personnel do not have these instructions to refer to, the siren system may not provide the intended audible warning and service personnel may be exposed to death, permanent hearing loss, or other bodily injury. File these instructions in a safe place and refer to them periodically. Give a copy of these instructions to new recruits and trainees. Also give a copy to anyone who is going to service or repair the siren.

Installation and Service

- Electrocution or severe personal injury can occur when performing various installation and service functions such as making electrical connections, drilling holes, or lifting equipment. Therefore only experienced electricians should install this product in accordance with national, state and any other electrical codes having jurisdiction. Perform all work under the direction of the installation or service crew safety foreman.
- The sound output of sirens is capable of causing permanent hearing damage. To prevent excessive exposure, carefully plan siren placement, post warnings and restrict access to areas near the sirens. Sirens may be operated from remote control points. Whenever possible, disconnect all siren power including batteries before working near the siren.
- After installation or service, test the siren system to confirm that it is operating properly. Test the system regularly to confirm that it will be operational in an emergency.
- If future service personnel do not have these warnings and all other instructions shipped with the equipment to refer to, the siren system may not provide the intended audible warning and service personnel may be exposed to death, permanent hearing loss, or other bodily injury. File these instructions in a safe place and refer to them periodically. Give a copy of these instructions to new recruits and trainees. Also, give a copy to anyone who is going to service or repair the sirens.

Operation

Failure to understand the capabilities and limitations of your siren system could result in permanent hearing loss, other serious injuries or death to persons too close to the sirens when you activate them or to those you need to warn. Carefully read and thoroughly understand all safety notices in this manual and all operations-related-items in all instruction manuals shipped with equipment. Thoroughly discuss all contingency plans with those responsible for warning people in your community, company, or jurisdiction.

Read and understand the information contained in this manual before attempting to install or service the siren.

Pay careful attention to the notice located on the equipment.

General Description

Introduction

This publication covers the installation of the Yagi and Omni Fiberglass Antennas.

Planning your Antenna System

Proper planning of your antenna system is significantly important. VHF and UHF are essentially line-of-site frequencies; therefore, radio transmission through a mountain or through the earth in a valley is not possible. Height is might. Get the antenna as high as possible. Increasing height by ten feet can make a significant difference and may add miles to the coverage. LMR400 antenna cable length can be up to 200 feet for VHF and 100 feet for UHF. If longer antenna cable length is necessary, higher quality cable is required. The general guideline is reflected power should never exceed 10% of the forward power. Some higher quality organizations use 5% maximum reflected power.

Consider the following guidelines:

- Do not have the antenna radiating element touching anything, if too close to an object, excessive reflected power can occur.
- Place antennas at least 1.5 feet or more from other objects.
- Separate multiple antennas vertically, not horizontally.
- Antenna cable entering a building requires grounded lightning protection at the building entry.

Installing the Antennas

⚠ CAUTION

Radio and antenna installation must conform to the system's FCC (or equivalent) license which specifies the RF frequency, modulation, RF power, antenna location and mounting height. Do not operate the radio system until the installation has been confirmed to comply with the license.

Follow these guidelines:

- Install antenna above the roofline
- Create the service loop diameter at 8-inch minimum radius
- Attach a gas discharge suppressor (to interrupt the antenna cable) to the ground plate mounted to the outside of the building. This properly grounds the antenna shield and prevents lightning from entering the building.

Installing the Yagi Antenna

Yagi Antenna Pre-Assembly Instruction

To pre-assemble the antenna, do the following:

1. Unpack the antenna and locate the following parts:
 - Boom (1-14 inches for 5 element model, 7/8 inch-diameter for 3 element model)
 - 3/8 diameter elements (y---3 = 3 elements, y----5 = 5 elements)
 - Gamma match parts bag
 - Mounting bracket parts bag
2. Find the proper element dimension chart for your antenna, within the antenna instructions, and trim each element according to your operating frequency. Use care to trim equal lengths from each end of each element ensuring that the mounting hole is at the center.

NOTE A: Proper trimming and adjustment is critical to the Voltage Standing Wave Ratio, known as VSWR. (High reflected power levels decrease forward power. The life of the radio and transmit capabilities are dependent upon the VSWR being low as possible).

NOTE B: If two frequencies are being used, then trim the antenna to the transmit frequency of the system where the antenna is mounted.

3. Insert the elements into their respective locations through the boom, starting with R1 (the reflective element) in the hole closest to the mounting holes. Then insert Dr, D1 etc. in that order.

NOTE A: Shortest element is furthest away from the mount and increases in size as it gets closer to the mount.

NOTE B: Be very careful to line up the holes and not cross thread when securing the elements in the next step. The bolts must tighten all the way down upon the lock washers.

4. Secure the elements with the stainless steel 10-32 hex bolts and #10 lockwashers provided.
5. Locate the connector/brass tube assembly in the gamma match parts bag and insert the assembly first through the connector bracket, then thread the connector into the bracket. Be sure to tighten the connector fully. A drop of Loctite or other thread lock may be used in the threads to eliminate the possibility of the connector loosening.
6. Slide the gamma link onto the driven element and assemble the gamma match as shown in figure 1 or 2 (under the antenna instructions provided by the antenna manufacturer). Set dimensions "A" and "B" to those shown in table 1. Setting the match to the dimensions shown for your antenna is a good starting point, which allows you to quickly line tune later. Complete the assembly by attaching the end cap onto the end of the gamma tube. The antenna is now ready for final tuning.

⚠ CAUTION

Antennas may cause severe burns. Do not touch the antenna while the radio is transmitting.

Final VSWR Tuning

To final tune the antenna, do the following:

1. Before final installation of the antenna, temporarily set it up in a clear area at least six feet above the ground.

NOTE A: Do not touch the antenna while the radio is transmitting.

NOTE B: Ensure antenna is not touching any conductive material and is pointed away from all objects and people. Pointing antenna at objects in close proximity may act as a reflector and create inaccurate readings.

2. Apply RF power to the antenna at the transmit frequency to be used at that antenna, and check for the low VSWR while performing each of the following steps.
 - A. Loosen the setscrew with the Allen key provided and make a slight adjustment to the aluminum gamma tube for the lowest VSWR (Reflected power).
 - B. Adjust the gamma link along the driven element for the lowest VSWR.
 - C. Repeat the above steps until the lowest VSWR is achieved. Reflected power must be less than 10% of the forward power.
 - D. Return to the dimensions shown in the antenna instructions, if there is any trouble achieving a good match. If the element dimensions are incorrect for the frequency being used, low VSWR may be unattainable. If the VSWR specification is still unattainable, replace the cable. (A simple ohm meter check of the cable does not guarantee that the antenna cable is good, due to the DMM not having the ability to check the cable at high frequencies.) If that does not take care of the problem, replace the antenna.

Mount Yagi Antenna

See “Figure 1 Yagi Antenna Installation Example” on page 10.

To install the Yagi antenna, do the following:

1. Install antenna, (using installation bracket or equivalent) as high as possible, such that the antenna cable and obstacles allows, and install on side of pole closest to the receiving station. Aim antenna at receiving station. Make sure the antenna elements are in the vertical direction.

Install a service loop when routing antenna cable.

NOTE: Objects around the antenna affect the antenna, keep antenna pointed away from objects.

2. Ensure antenna cable connections are tight. Seal all connection points with heat shrink or tape and seal with Scotch Coat, or equivalent.

3. Apply RF power to the antenna at the transmit frequency to be used at that antenna, and check the VSWR (Reflected power). Reflected power must be less than 10% of the forward power.

If the VSWR specification is unattainable, replace the cable (a simple ohm meter check of the cable does not guarantee that the antenna cable is good, due to the DMM not having the ability to check the cable at high frequencies). If that does not take care of the problem, replace the antenna.

Installing the Omni Antenna

NOTE: No tuning is required for this model.

See “Figure 2 Omni Antenna Installation Example” on page 10

To install the Omni antenna, do the following:

1. Install antenna, (using installation bracket or equivalent) as high as possible, such that the antenna cable and obstacles allows, and install on side of pole closest to the receiving station.

Install a service loop when routing antenna cable.

NOTE: Objects around the antenna affect the antenna, keep antenna away from objects, and at least $\frac{1}{4}$ wavelength from siren pole.

($\lambda = C/f$, where $C = 1.18 \times 10^{10}$ in/sec)

2. Ensure antenna cable connections are tight. Seal all connection points with heat shrink or tape and seal with Scotch Coat, or equivalent.
3. Apply RF power to the antenna at the transmit frequency to be used at that antenna, and check the VSWR (Reflected power). Reflected power must be less than 10% of the forward power.

If the VSWR specification is unattainable, replace the cable (A simple ohm meter check of the cable does not guarantee that the antenna cable is good, due to the DMM not having the ability to check the cable at high frequencies). If that does not take care of the problem, replace the antenna.

Figure 1 Yagi Antenna Installation Example

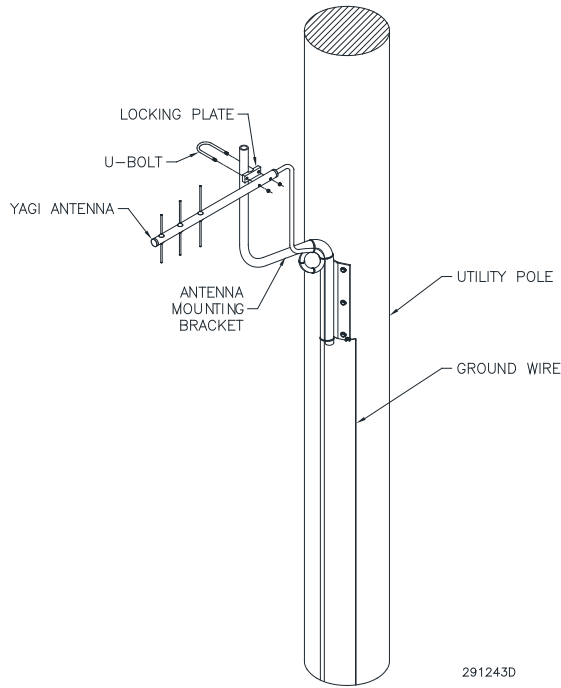

Figure 2 Omni Antenna Installation Example

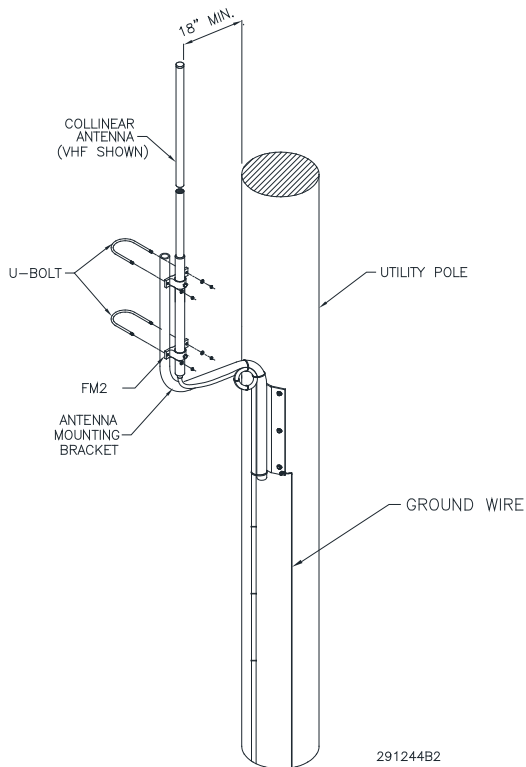
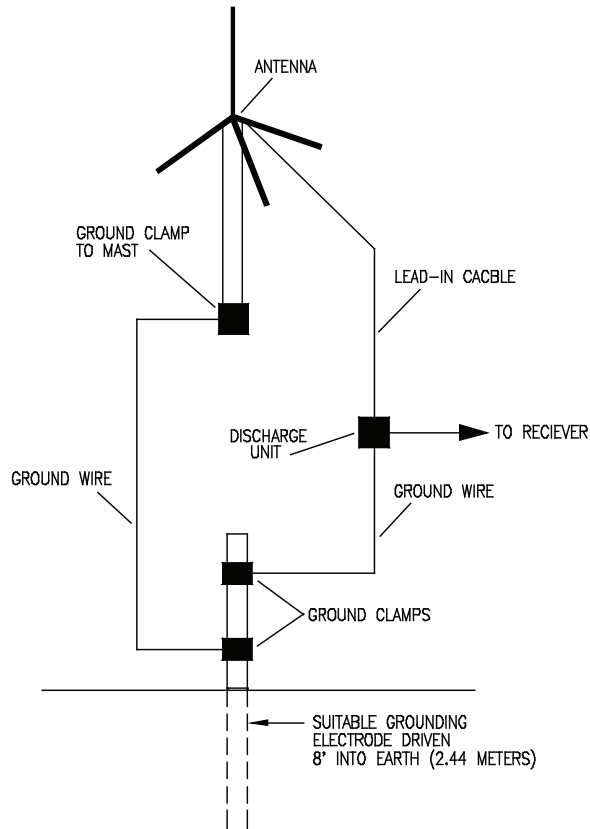

Figure 3 Antenna Grounding

EXAMPLE OF ANTENNA GROUNDING AS PER NATIONAL ELECTRICAL CODE INSTRUCTIONS (REFER TO N.E.C. FOR COMPLETE INSTRUCTIONS.)



- A. USE NO. 10 AWG COPPER, NO. 8 AWG ALUMINUM, NO. 17 AWG COPPER CLAD STEEL OR BRONZE WIRE, OR LARGER AS GROUND WIRE FOR BOTH MAST AND LEAD-IN.
- B. SECURE LEAD-IN CABLE FROM ANTENNA TO ANTENNA DISCHARGE UNIT AND MAST GROUND WIRES TO HOUSE WITH STAND-OFF INSULATORS, SPACED FROM 4 FEET (1.22 METERS) TO 6 FEET (1.83 METERS) APART.
- C. MOUNT ANTENNA DISCHARGE UNITS AS CLOSE TO WHERE LEAD-IN CABLE ENTERS HOUSE AS POSSIBLE.

291160

Getting Service

If you are experiencing any difficulties, contact Federal Signal Customer Care at: 800-548-7229 or 708-534-3400 extension 5822 or Technical Support at: 800-524-3021 or 708-534-3400 extension 7329 or through e-mail at: techsupport@fedsig.com. For instruction manuals and information on related products, visit: <http://www.fedsig.com/>

Figure 4 Typical Antenna Pole Mount (AMP-P) Installation

TYPICAL ANTENNA POLE MOUNT (AMB-P) INSTALLATION, REF. DWG.

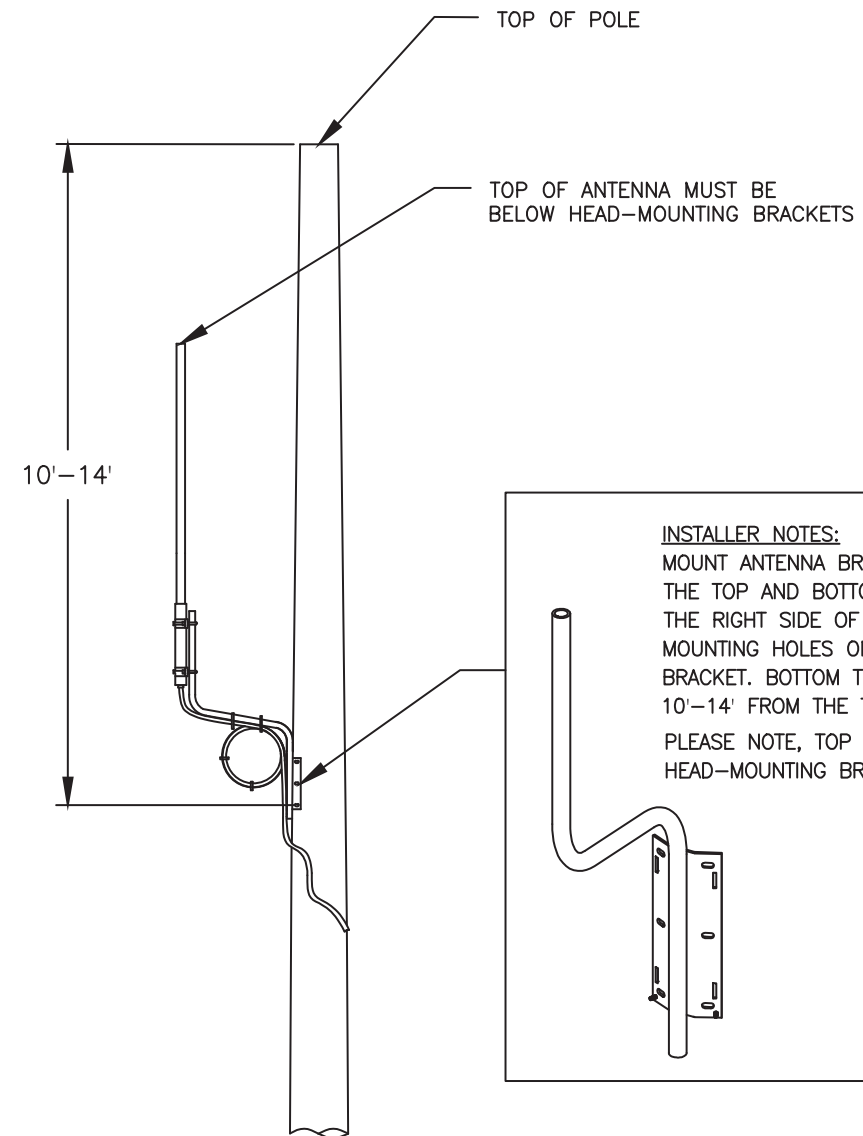
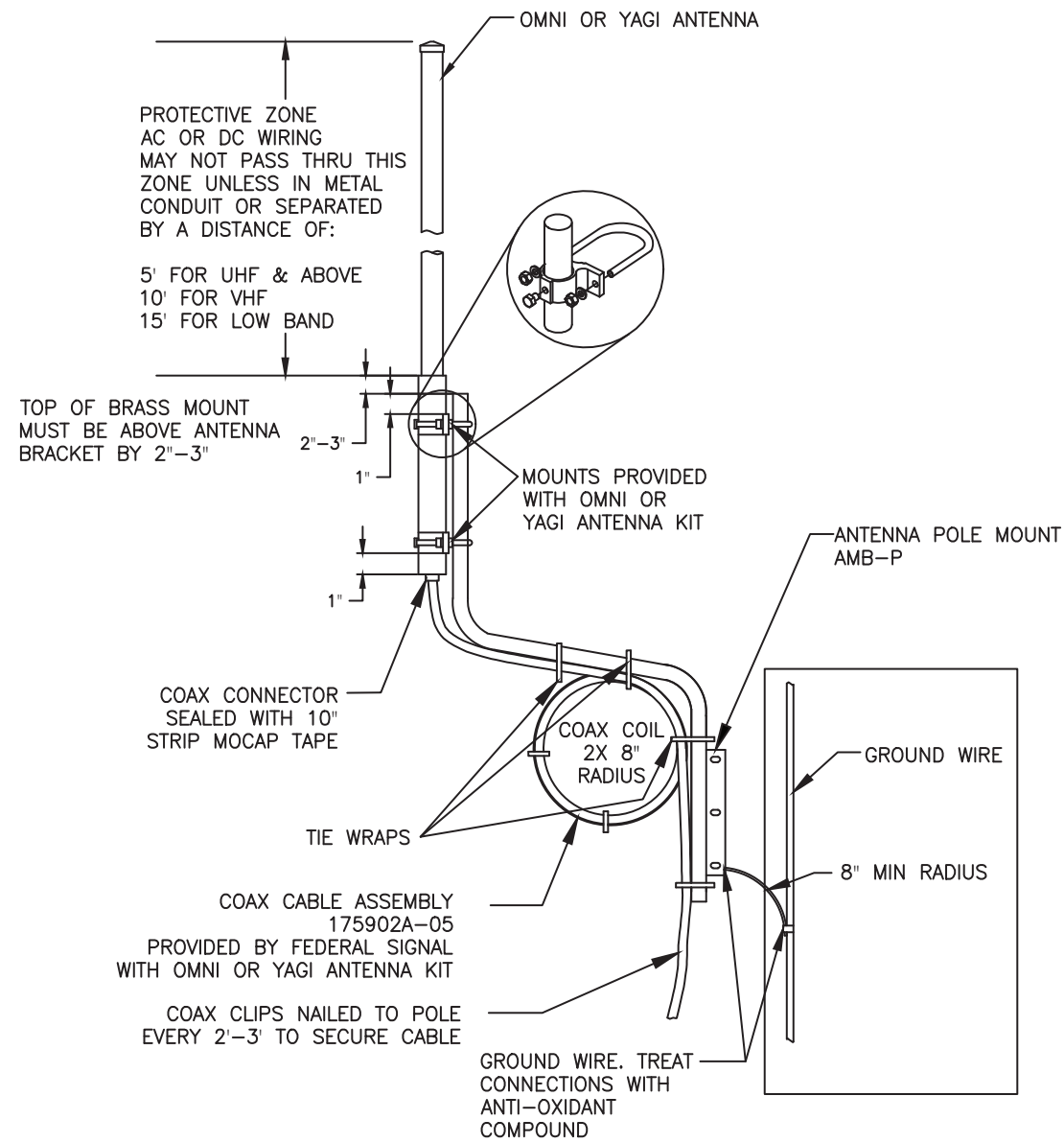

INSTALLER NOTES:
 MOUNT ANTENNA BRACKET TO TIMBER POLE USING THE TOP AND BOTTOM TWO MOUNTING HOLES ON THE RIGHT SIDE OF THE BRACKET AND THE TWO MOUNTING HOLES ON THE LEFT SIDE OF THE BRACKET. BOTTOM TWO HOLES ARE MOUNTED 10'-14' FROM THE TOP OF THE POLE.
 PLEASE NOTE, TOP OF ANTENNA MUST BE BELOW HEAD-MOUNTING BRACKETS.

Tolerances Unless Otherwise Specified	
Angles	±0.5°
x.xx	±.015
x.xxx	±.005

SIGNAL DIVISION
 Federal Signal Corporation
 2645 FEDERAL SIGNAL DRIVE - UNIVERSITY PARK, IL 60466

A	TEXT REVISIONS	02/27/18	JLM
REV.	CHANGE	DATE	BY

FINISH	N/A REMOVE BURRS, SHARP CORNERS AND EDGES	
MATERIAL	N/A	UNIT OF MEASURE PC
NAME	TYPICAL ANTENNA POLE MOUNT INSTALLATION, REF. DWG.	

MATERIAL DESCRIBED AND INFORMATION CONVEYED IS PROPRIETARY TO FEDERAL SIGNAL CORPORATION, IS OR MAY BE THE SUBJECT OF PATENT APPLICATIONS, AND MAY NOT BE COPIED, DIVULGED TO OTHERS, OR USED FOR MANUFACTURING WITHOUT CONSENT.		
DRAWN BY JLM	CHKD. BY ARP	SCALE AT B SIZE: NONE
DATE 1/12/18	DATE 1/12/18	DO NOT SCALE DRAWING
DRAWING NUMBER		850000671A

