

# Pathfinder® PF400

## Siren and Light Controller



### FEATURES

- 400 W Programmable siren/light controller with remote-mount amplifier
- (4) 100 W independent audio channels
- Integrated multi-tone capability
- Integrated Rumbler® traffic-clearing capability
- Capable of Rumbler and dual-tone in a single amplifier
- PF400Q models feature the traditional trademarked Q-Siren tone
- FS Vehicle Integration/On-Board Diagnostics Integration (OBDII)
- Library of selectable siren tones
- (4) FS Convergence Network ports
- (7) programmable inputs and (16) programmable solid-state outputs
- Standard voice messages are available in English, Spanish, and French Canadian to broadcast alerts. Custom voice messages available for an additional fee
- Convergence Network Configuration Software allows for easy customization of siren and light controls
- 12/24 Vdc
- Five-year warranty

Pathfinder® PF400 is a 400-Watt, programmable siren and light controller available with remote surface-mount controllers or handheld controller. Pathfinder PF400 is packed with features such as multi-tone and Rumbler traffic-clearing capability along with optional On-Board Diagnostics (OBDII) integration. Pathfinder PF400 is easy to install and incorporates Convergence Network Configuration Software to provide a high-level of customizable control capability. Convergence Network Configuration Software is available as a download from the Federal Signal website making it easy to program one vehicle –or an entire fleet – from your laptop.

### Controller Features

Pathfinder PF400 provides the user with customized control of the siren, warning lights, directional lights, and other accessories. Pathfinder PF400 can control the SignalMaster™ directional functions in light bars, ILS systems and “stick” lights that are compatible with FS Convergence Network as well as Latitude™ 3-wire SignalMaster. For convenient visual reference, the Pathfinder PF400 emulates the selected pattern of the SignalMaster operation.

All controller options feature programmable buttons that can be programmed for press-on/off, momentary, timed, step-thru and multiple different blinking styles. The button brightness can be dimmed or turned-off for stealth operation. Over (100) labeling stickers, such as alley, gun lock, and wait allow for further customization of the controller.

Button color can be programmed through the Convergence Network Configuration Software. The remote models can be programmed in dual-color (Red/Blue) while the Handheld and 17-button can be programmed in nine different colors - Red, Blue, Green, Cyan, Magenta, Yellow, White, Purple and Amber.

### APPROVALS

- SAE J1849
- CCR Title 13, Class A
- NFPA 1900

### FS TECHNOLOGIES



# Pathfinder® PF400 MODELS

## PF400Q

Remote Surface-mount Controller with (4) Push-buttons and Rotary Knob



## PF400QS17B/PF400S17B

Remote Surface-mount Controller with (17) Push-buttons and Slide Switch



## PF400QH/PF400H

Handheld Controller / Microphone with (14) Push-buttons



## PF400QR/PF400R

Remote Surface-mount Controller with Rotary Knob and Slide Switch



### Integrated Rumbler® and Multi-Tone Capability

The Pathfinder PF400 is available with integrated Rumbler traffic-clearing capability. This allows the Pathfinder PF400 to produce a Rumbler tone without the need for a separate externally mounted amplifier. Rumbler capability requires the purchase of Rumbler speakers and vehicle-specific mounting kit.

Pathfinder PF400 provides the ability for single-, dual-, tri-, or quad-tone capability depending on the amount of speakers used. The Pathfinder PF400 is capable of doing dual-tone and Rumbler in a single amp.



RBKIT-SOLO



RBKIT2-COMPACT

### FS Vehicle Integration/On-Board Diagnostics Integration (OBDII)

The FS Vehicle Integration is a simple plug-in connection using the existing vehicle CAN bus system. The FS Vehicle Integration uses a vehicle-specific cable (sold separately) to seamlessly integrate with the vehicle allowing light and siren control with vehicle events such as door open, headlight, brake, speed, park, etc. The use of the FS Vehicle Integration removes the need to separately wire certain options such as horn ring transfer or ignition (vehicle-type dependent).



OBD-CABLE6-1

For a full list of vehicles, please visit [www.fedsig.com](http://www.fedsig.com).

## Timer Feature

The Pathfinder PF400 built-in timer feature senses ignition ON/OFF and allows the selection of multiple time settings. Various devices can be wired to relay outputs on the Pathfinder amplifier (such as in-car video DVRs, radios, and laptop chargers), and a security timer can be programmed to minimize the possibility of unauthorized gun release. Pathfinder PF400 timer feature allows the end user to avoid the extra cost of an external timer per vehicle by allowing each device to be turned off at a different time, unlike many one setting external timers currently in the market.

## Amplifier Features

The Pathfinder PF400 produces Wail, Yelp, Priority, and an Air Horn sound by default. The horn-ring transfer feature enables the driver to control siren tones as well as patterns by pressing the horn button. A library of other selectable siren tones are available including Unitrol™ branded siren tones such as Wail, Yelp, Futura, Hi-Lo, Ultra Hi-Lo, Alarm, Air Horn, and Hetro. PA, radio rebroadcast, and Air Horn are standard in the Pathfinder PF400. Pathfinder PF400 also includes (4) serial ports to be used with the FS Convergence Network devices such as light bars or directional warning lights for easy "plug-n-play" installation.

The Pathfinder PF400 has sixteen solid-state relays: ten-ampere high and six five-ampere high, and four 500 mA low. The maximum output current for each relay can be set with the Convergence Network Configuration Software.

## Programming Software Features

The Convergence Network Configuration Software is available as a download from the FS website and siren configurations can be created via laptop computer. Configured programs can be extracted, modified, and stored for ease of service and re-use. The Federal Signal Convergence Network allows the user to "plug-and-play" simply by connecting the siren to the vehicle's light bar. Pathfinder PF400 gives the user the ability to clone an entire fleet of siren functions. The user simply connects the Pathfinder PF400 to a PC and downloads the functions of the programmed software onto a USB drive to download functions to each siren.

## Speaker Connections

The Pathfinder PF400 can drive one to four 100-Watt speakers. The PF400 is capable of multiple speaker and tone configurations.

Dual-tone with Rumbler can be accomplished without the need for an external Rumbler amplifier.

Low-frequency siren output in the table below refers to the Rumbler speaker. The BP200, AS100, and ES100C speakers are high-frequency.

If playing a Q-Tone, BP200 or AS124 speakers are recommended.

APPLICATION	SIREN	CHANNEL ONE	CHANNEL TWO	CHANNEL THREE	CHANNEL FOUR	SIREN OUTPUT
FIRE APPARATUS/ AMBULANCE	PF400Q		BP200	RBKIT2-COMPACT	ES100C or AS124	Dual-tone High, Single-tone Low
			BP200		BP200	Dual-tone High
			BP200		RBKIT2-COMPACT (one on each channel)	Single-tone High, Single-tone Low
FIRE CHIEF/ FIRE COMMAND	PF400Q	AS124	AS124	RBKIT2-COMPACT or (2) RBKIT-SOLO (one on each channel)		Dual-tone High, Dual-tone Low
POLICE	PF400	ES100C	ES100C	RBKIT2-COMPACT or (2) RBKIT-SOLO (one on each channel)		Dual-tone High, Dual-tone Low
		ES100C	ES100C	ES100C	RBKIT-SOLO	Tri-tone High, Single-tone Low
		ES100C	ES100C	ES100C	ES100C	Quad-tone High

### Rear Expansion Module (EXPMOD-2)

The EXPMOD-2 Rear Expansion Module works with any Pathfinder siren to provide an additional (16) 7.5 Amp flashing outputs and (2) 20 Amp control outputs. The Rear Expansion Module makes installation faster and easier by giving you full control of OEM brake, tail, turn, reverse and third brake light lighting without the use of additional flashers. (9) blackout relays are also included that allow trained officers to have the ability to cut off all rear lighting to avoid detection. The Rear Expansion Module includes (3) serial ports to be used with the FS Convergence Network devices such as light bars or directional warning lights for easy “plug-and-play” installation.



EXPMOD-2

The Rear Expansion Module is controlled by a Pathfinder siren that can be programmed through the Convergence Network Configuration Software to provide a high-level of distributed and customizable control capability. Up to two Rear Expansion Modules can be used with a Pathfinder Siren providing a total of (32) 7.5 Amp flashing outputs and (4) 20 Amp control outputs. Vehicle specific rear taillight connection wire harnesses are available for the Dodge Charger Pursuit, Chevrolet Tahoe, Dodge Durango, and Ford Police Interceptor Utility.

### 24-Channel Expansion Module (EXPMOD24)

The EXPMOD24 24-Channel Expansion module works with any Pathfinder siren to provide an additional (24) flashing outputs to a Pathfinder System. (2) of the (24) outputs feature diode-protected inputs to serve as OEM LED brake light flash control. The 24-Channel Expansion Module is controlled by a Pathfinder siren that can be programmed through the Convergence Network Configuration Software to provide a high-level of distributed and customizable control capability. The maximum output current for each relay can also be set with the Convergence Network Configuration Software. The 24-Channel Expansion Module is potted to help protect it from unfavorable weather conditions making it ideal for under the hood mounting. Up to four 24-Channel Expansion Modules can be used with a Pathfinder siren.



EXPMOD24

### 32-Channel Expansion Module (EXPMOD32)

The 32-Channel Expansion module works with any Pathfinder PF400 siren to provide an additional 32 flashing outputs to a Pathfinder system. The Expansion Module makes installation faster and easier by providing 3-SPDT, diode-isolated relays allowing for brake light blackout and/or brake/taillight flash, eliminating the need for a taillight flasher. The blackout feature allows trained officers to have the ability to cut off all rear lighting to avoid detection.



EXPMOD32

The 32-Channel Expansion Module is programmed through the Convergence Network Configuration Software to provide a high level of distributed and customizable control capability. The maximum output current for each relay can also be set within the software. The 32-Channel Expansion Module is potted to help protect it from unfavorable weather conditions making it ideal for under the hood mounting.

Up to four 32-Channel Expansion modules can be used in a system. Each Expansion Module has a module identifier to easily help identify while programming in the Convergence Network Configuration software.

### Power Distribution Module (PFPDM-1)

The PFPDM-1 Power Distribution Module provides electrical power from one main power source. The Power Distribution Module makes installation faster and easier and increases reliability due to having fewer failure points. In the case of a product losing power, the Power Distribution Module features diagnostic LEDs that will allow the failure point to be quickly located. The Power Distribution Module includes (4) serial ports to be used with the FS Convergence Network devices, such as light bars or directional warning lights, for easy “plug-and-play” installation. The Power Distribution Module also includes (4) programmable outputs that can be programmed through the Convergence Network Software to provide a high-level of distributed and customizable control capability.



PFPDM-1

### On Scene Sync Module (PFSYNC-1)

The PFSYNC-1 On Scene Sync Module works in conjunction with any Pathfinder Siren to provide synchronization between multiple “like-programmed” vehicles. On Scene Sync Module uses a GPS signal to maintain timing between vehicles providing the capability to synchronize warning lights, and voice messages to unify the visual and audible warning of multi-vehicle response. An ambient light sensor is also included in the On Scene Sync Module to auto-adjust warning lights.



PFSYNC-1

### SPECIFICATIONS

PATHFINDER PF400																					
AUDIO OUTPUT POWER	400 W																				
INPUT VOLTAGE	12/24 Vdc																				
STANDBY CURRENT	< 0.1 A																				
MAX INPUT CURRENT	90 A (siren and relays)																				
OPERATING TEMP	-40° to +176° F (-40° to +80°C)																				
POLARITY	Negative ground only																				
FREQUENCY RANGE	182 to 1600 Hz																				
AMPLIFIER PHYSICAL SPECIFICATIONS																					
	<table border="1"> <thead> <tr> <th></th> <th>PF400Q</th> <th>PF400QR/PF400R</th> <th>PF400QH/PF400H</th> <th>PF400QS17B/PF400S17B</th> </tr> </thead> <tbody> <tr> <td>HEIGHT</td> <td></td> <td>2.5 in (6.4 cm)</td> <td></td> <td></td> </tr> <tr> <td>WIDTH</td> <td></td> <td>6.0 in (15.2 cm)</td> <td></td> <td></td> </tr> <tr> <td>LENGTH</td> <td></td> <td>11.0 in (27.9 cm)</td> <td></td> <td></td> </tr> </tbody> </table>		PF400Q	PF400QR/PF400R	PF400QH/PF400H	PF400QS17B/PF400S17B	HEIGHT		2.5 in (6.4 cm)			WIDTH		6.0 in (15.2 cm)			LENGTH		11.0 in (27.9 cm)		
	PF400Q	PF400QR/PF400R	PF400QH/PF400H	PF400QS17B/PF400S17B																	
HEIGHT		2.5 in (6.4 cm)																			
WIDTH		6.0 in (15.2 cm)																			
LENGTH		11.0 in (27.9 cm)																			
CONTROLLER PHYSICAL SPECIFICATIONS																					
	<table border="1"> <thead> <tr> <th></th> <th>PF400Q</th> <th>PF400QR/PF400R</th> <th>PF400QH/PF400H</th> <th>PF400QS17B/PF400S17B</th> </tr> </thead> <tbody> <tr> <td>HEIGHT</td> <td>2.5 in (6.4 cm)</td> <td>2.5 in (6.4 cm)</td> <td>6.0 in (15.2 cm)</td> <td>3.3 in (8.4 cm)</td> </tr> <tr> <td>WIDTH</td> <td>6.8 in (17.3 cm)</td> <td>6.0 in (15.2 cm)</td> <td>2.5 in (6.4 cm)</td> <td>6.8 in (17.3 cm)</td> </tr> <tr> <td>LENGTH</td> <td>1.2 in (3.0cm)</td> <td>1.5 in (3.5 cm)</td> <td>1.3 in (3.3 cm)</td> <td>1.4 in (3.6 cm)</td> </tr> </tbody> </table>		PF400Q	PF400QR/PF400R	PF400QH/PF400H	PF400QS17B/PF400S17B	HEIGHT	2.5 in (6.4 cm)	2.5 in (6.4 cm)	6.0 in (15.2 cm)	3.3 in (8.4 cm)	WIDTH	6.8 in (17.3 cm)	6.0 in (15.2 cm)	2.5 in (6.4 cm)	6.8 in (17.3 cm)	LENGTH	1.2 in (3.0cm)	1.5 in (3.5 cm)	1.3 in (3.3 cm)	1.4 in (3.6 cm)
	PF400Q	PF400QR/PF400R	PF400QH/PF400H	PF400QS17B/PF400S17B																	
HEIGHT	2.5 in (6.4 cm)	2.5 in (6.4 cm)	6.0 in (15.2 cm)	3.3 in (8.4 cm)																	
WIDTH	6.8 in (17.3 cm)	6.0 in (15.2 cm)	2.5 in (6.4 cm)	6.8 in (17.3 cm)																	
LENGTH	1.2 in (3.0cm)	1.5 in (3.5 cm)	1.3 in (3.3 cm)	1.4 in (3.6 cm)																	
SHIP WEIGHT																					
	<table border="1"> <thead> <tr> <th></th> <th>PF400Q</th> <th>PF400QR/PF400R</th> <th>PF400QH/PF400H</th> <th>PF400QS17B/PF400S17B</th> </tr> </thead> <tbody> <tr> <td>SHIP WEIGHT</td> <td>6.0 lb (2.7 kg)</td> <td>6.0 lb (2.7 kg)</td> <td>5.0 lb (2.3 kg)</td> <td>6.0 lb (2.7 kg)</td> </tr> </tbody> </table>		PF400Q	PF400QR/PF400R	PF400QH/PF400H	PF400QS17B/PF400S17B	SHIP WEIGHT	6.0 lb (2.7 kg)	6.0 lb (2.7 kg)	5.0 lb (2.3 kg)	6.0 lb (2.7 kg)										
	PF400Q	PF400QR/PF400R	PF400QH/PF400H	PF400QS17B/PF400S17B																	
SHIP WEIGHT	6.0 lb (2.7 kg)	6.0 lb (2.7 kg)	5.0 lb (2.3 kg)	6.0 lb (2.7 kg)																	

Rear View of PF400

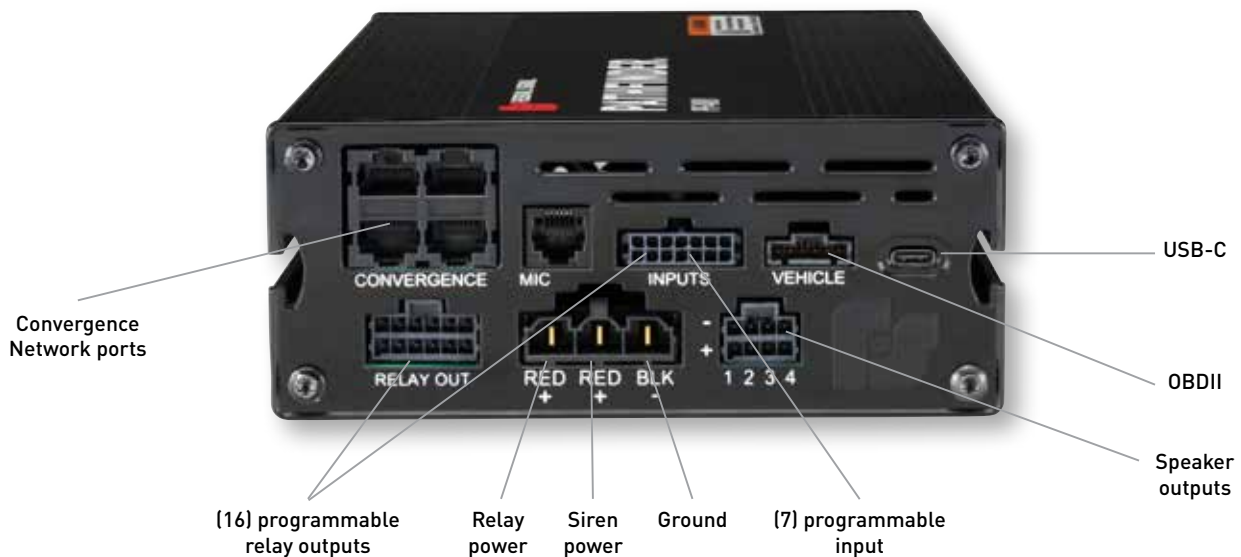

**PATHFINDER DIMENSIONS**

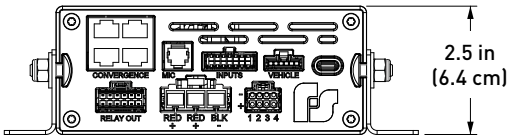
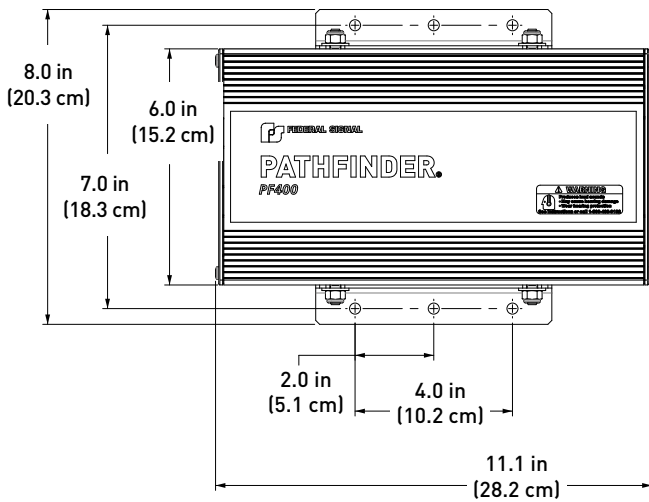

**REMOTE HEAD CONTROLLER**

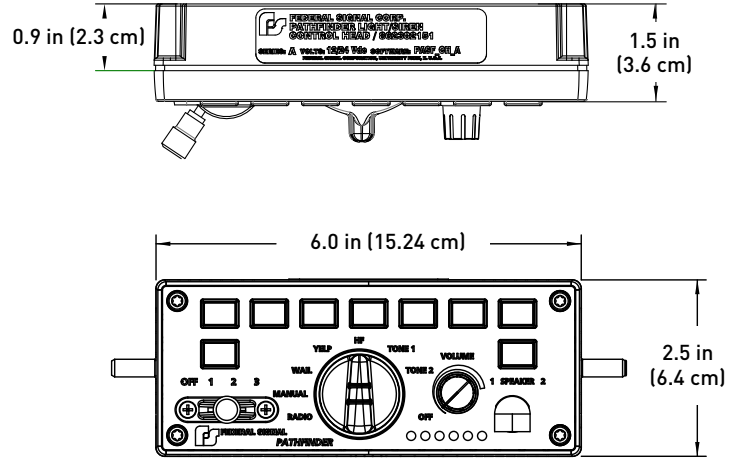

**HANDHELD CONTROLLER**

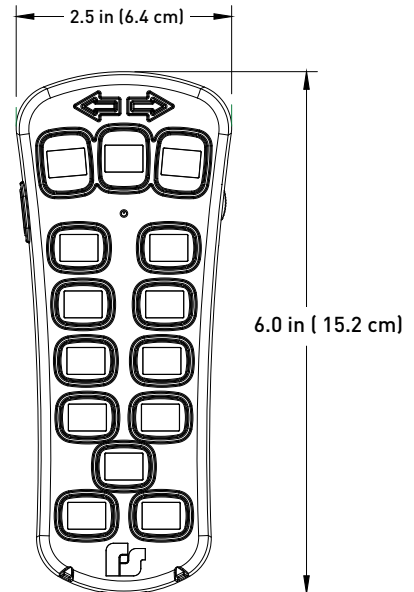

**PF400Q REMOTE HEAD CONTROLLER**

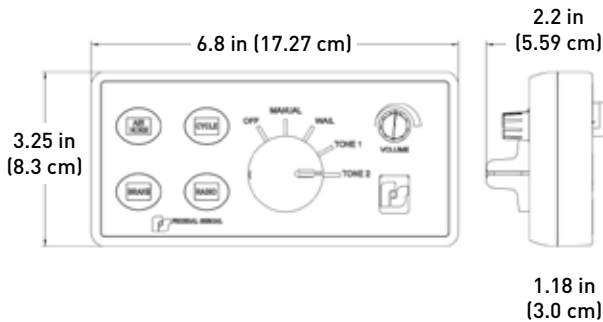

**17-BUTTON CONTROLLER**

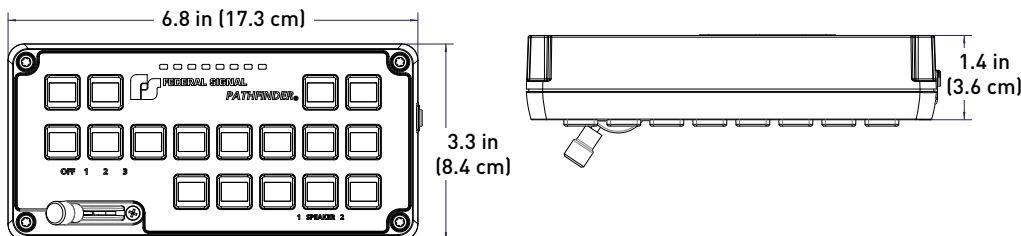

## HOW TO ORDER

<b>PF400S17B</b>	Siren/Light Controller with 17-button controller, 400 W
<b>PF400H</b>	Siren/Light Controller with Handheld controller/microphone, 400 W
<b>PF400R</b>	Siren/Light Controller with Remote surface mount controller, 400 W

### INTEGRATED Q-TONE MODELS

<b>PF400Q</b>	Siren/Light Controller with Remote surface mount controller, 400 W, integrated Q-tone
<b>PF400QS17B</b>	Siren/Light Controller with 17-button controller, 400 W, integrated Q-tone
<b>PF400QH</b>	Siren/Light Controller with Handheld controller/microphone, 400 W, integrated Q-tone
<b>PF400QR</b>	Siren/Light Controller with Remote surface mount controller, 400 W, integrated Q-tone
<b>PF400QAMP</b>	PF400Q Amplifier, no controller, integrated Q-tone

### ACCESSORIES

<b>PFSYNC-1</b>	On Scene Sync Module
<b>RBKIT-SOLO*</b>	Single Rumbler Solo low frequency speaker for use with sirens with integrated Rumbler capability
<b>RBKIT2-COMPACT*</b>	Pair of Rumbler Compact low frequency speakers for use with sirens with integrated Rumbler capability
<b>OBDCABLE6-1</b>	6-ft OBDII interface cable, for use on 2018-2020 Chevrolet Tahoe, 2013-2019 Ford Police Interceptor Utility, 2018-2019 Ford F-150, 2018-2021 Chevrolet Silverado
<b>OBDCABLE6-2</b>	6-ft OBDII interface cable, for use on 2020-2024 Ford Police Interceptor Utility
<b>OBDCABLE6-3</b>	6-ft OBDII interface cable, for use on 2020-2021 Ford Expedition, 2020 Ford F-150, and 2020-2022 Ford F-250/F-350/F-450/F-550 (Models equipped with 4" or 8" entertainment screen only)
<b>OBDCABLE6-DGCAN</b>	6-ft OBDII interface cable, for use on 2018-2024 Dodge Charger Pursuit and 2018-2023 Dodge Durango, and 2018-2023 Dodge Ram 1500
<b>OBDCABLE25-1</b>	25-ft OBDII interface cable, for use on 2018-2020 Chevrolet Tahoe, 2013-2019 Ford Police Interceptor Utility, 2018-2019 Ford F-150, 2018-2021 Chevrolet Silverado
<b>OBDCABLE25-2</b>	25-ft OBDII interface cable, for use on 2020-2024 Ford Police Interceptor Utility
<b>OBDCABLE25-3</b>	25-ft OBDII interface cable, for use on 2020-2021 Ford Expedition, 2020 Ford F-150, and 2020-2022 Ford F-250/F-350/F-450/F-550 (Models equipped with 4" or 8" entertainment screen only)

<b>OBDCABLE25-DGCAN</b>	25-ft OBDII interface cable, for use on 2018-2024 Dodge Charger Pursuit and 2018-2023 Dodge Durango, and 2018-2023 Dodge Ram 1500
<b>OBDCABLE8-GMCAN</b>	8-ft OBDII interface cable, for use on 2021-2024 Chevrolet Tahoe
<b>OBDCABLE20-GMCAN</b>	20-ft OBDII interface cable, for use on 2021-2024 Chevrolet Tahoe
<b>OBDCABLE8-4</b>	8-ft OBDII interface cable, for use on 2021-2024 Ford Mustang Mach-E and 2022-2024 Ford F-150 Lightning
<b>OBDCABLE20-4</b>	20-ft OBDII interface cable, for use on 2021-2024 Ford Mustang Mach-E and 2022-2024 Ford F-150 Lightning
<b>PFPDM-1</b>	Power Distribution Module, 100 A max load
<b>EXPMOD24</b>	24-Channel Expansion Module
<b>EXPMOD32</b>	32-Channel Expansion Module
<b>EXPMOD-2</b>	Rear Expansion Module, (18) solid-state programmable relay outputs, (16) 7.5 A flashing outputs and (2) 20 A control outputs
<b>EXPHARN01</b>	Rear taillight connection wire harness for use with rear expansion module, Dodge Charger Pursuit, 2015-2024
<b>EXPHARN03</b>	Rear taillight connection wire harness for use with rear expansion module, Ford Police Interceptor Utility, 2020-2024
<b>EXPHARN04</b>	Rear taillight and rear liftgate lighting connection wire harness for use rear expansion module, Dodge Durango, 2018-2023
<b>EXPHARN05</b>	Rear taillight connection wire harness for use with rear expansion module, Chevrolet Tahoe, 2021-2023
<b>PFSPLTR-4</b>	4-to-1 splitter



Pathfinder, Rumbler, Unitrol, Latitude and SignalMaster are registered trademarks of Federal Signal Corporation. Ford, Chevrolet, and Dodge are all trademarks of their respective owners.

Warning: Sirens and Speakers may produce LOUD sounds necessary to request the right-of-way. Sirens and Speakers may cause hearing damage. Wear hearing protection.