

## INSTALLATION AND MAINTENANCE INSTRUCTIONS FOR MINI-JETSTROBE™ MODELS SJL2110, SJL2111, SJL2112. SJL2120, SJL2110M, AND SJL2120M

### SAFETY MESSAGE TO INSTALLERS OF FEDERAL SIGNAL LIGHT SYSTEMS

People's lives depend on your safe installation of our products. It is important to read, understand and follow all instructions shipped with the products. In addition, listed below are some other important safety instructions and precautions you should follow:

- To properly install a light assembly: you must have a good understanding of automotive electrical procedures and systems, along with proficiency in the installation and use of safety warning equipment.
- When drilling into a vehicle structure, be sure that both sides of the surface are clear of anything that could be damaged.
- A light system is a high current device. In order for it to function properly, a separate ground connection must be made. If practical, it should be connected to the negative battery terminal. At a minimum, it may be attached to a solid metal body or chassis part that will provide an effective ground path as long as the light system is to be used.
- Locate light system controls so the VEHICLE and CONTROLS can be operated safely under all driving conditions.
- You should frequently inspect the light system to ensure that it is operating properly and that it is securely attached to the vehicle.
- File these instructions in a safe place and refer to them when maintaining and/or reinstalling the product.

Failure to follow all safety precautions and instructions may result in property damage, serious injury, or death to you or others.

### I. GENERAL.

The Federal Mini-JetStrobe™ Lightbar is the most aerodynamic strobe bar available today. It utilizes the latest in solid-state electronics and strobe technology. The highly effective quadruple flash pattern is produced by powerful, highly efficient, and reliable power supplies. Some models incorporate a low intensity double flash mode which reduces power consumption by 60%.

Areas not occupied by strobe heads are available to place the following options: takedown light, halogen flashing lamp, steady burn red, brake/tail light, and work light.

### II. UNPACKING.

After unpacking the lightbar, inspect it for damage that may have occurred in transit. If the unit has been damaged, file a claim immediately with the carrier, stating the extent of damage. Carefully check all envelopes, shipping labels and tags before removing or destroying them.

### III. INSTALLATION.

#### A. General.

The lightbar is completely wired at the factory and does not require any additional internal wiring. All the conductors necessary for control of any and all basic and optional functions are contained in the cable.

The basic light functions of the unit must be controlled by a user-supplied control head.

Before proceeding, ensure that the lightbar has been installed on the vehicle roof in accordance with the instructions packed with the mounting kit. Route the lightbar cable as described below.

### WARNING

Light system controls must be located so that VEHICLE and CONTROLS can be operated safely under all driving conditions.

1. Route the control cable into the vehicle and under the dash, near the eventual location of the user-supplied control head.
2. For proper light operation, the control cable must be properly terminated inside the user-supplied control head. Using the appropriate wiring diagram (figures 1 through 5) as a guide, make the appropriate electrical connections shown in Table 1. Ensure that an adequate fuse is installed as shown in the appropriate figure.

**CAUTION**

Reverse polarity may damage the power supply and prevent operation. Ensure that correct polarity is observed.

3. Connect the black lead to chassis ground.

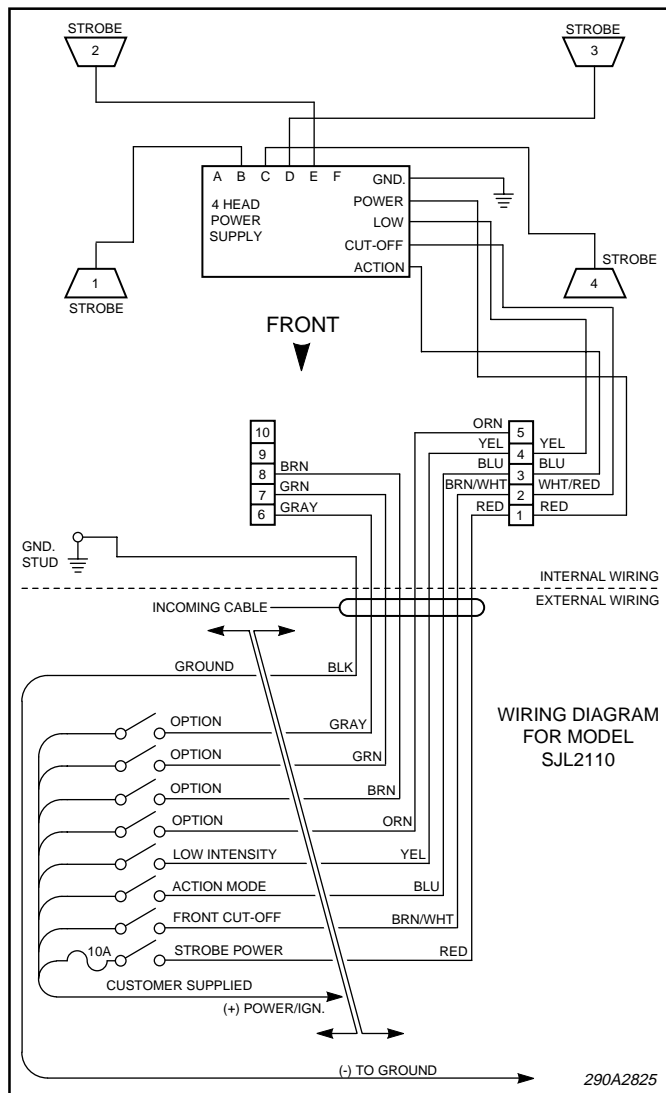

Figure 1.

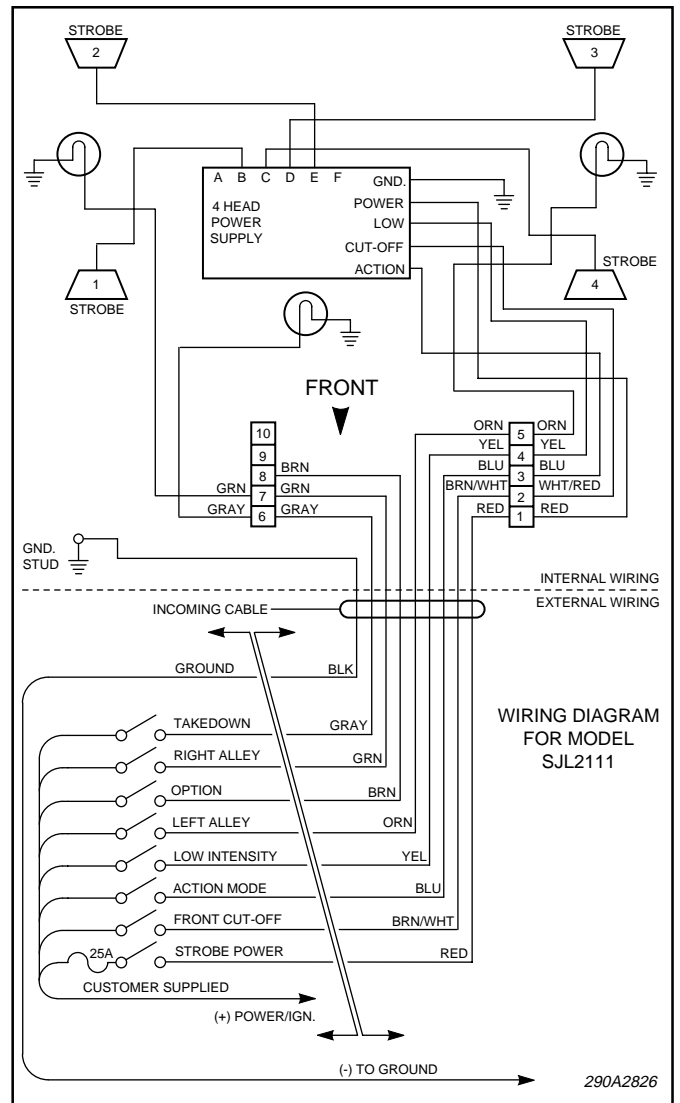

Figure 2.

**NOTE**

Most of the lightbar functions can be activated by applying 12VDC to the appropriate control line. The heavy black lead (-) must be connected to vehicle ground, to perform a function check.

**B. Side Facing Strobe Insert (JSFEI) Installation.**

**NOTE**

The four insert clips and four #4 screws contained in the packing carton will be used in the following steps.

1. See figure 6. Position two insert clips on the side facing reflector/flash tube assembly and press the clips until they slide into position.

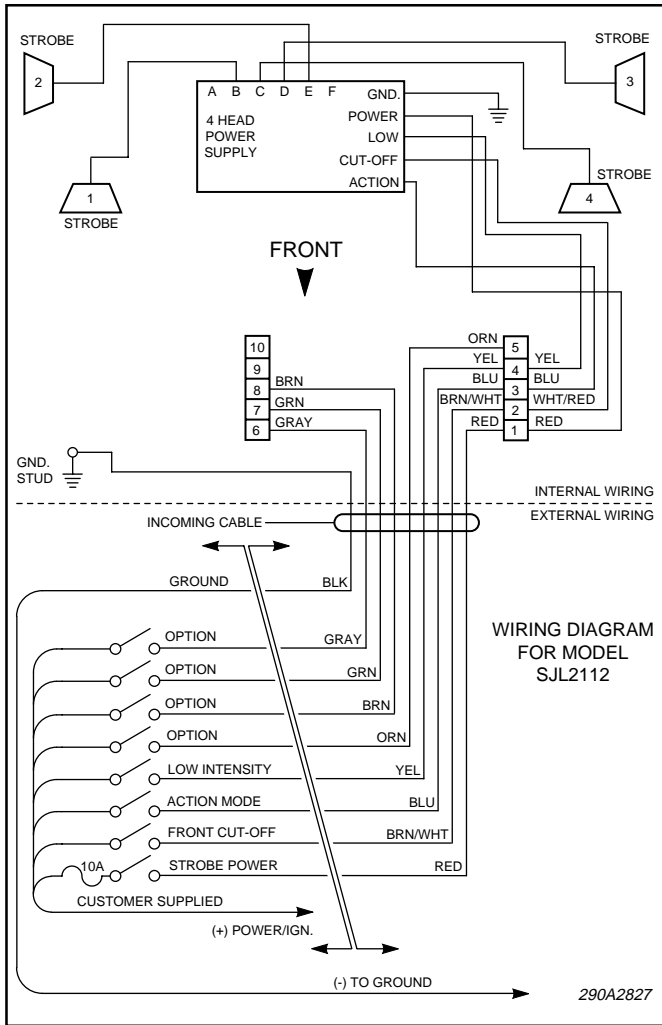

Figure 3.

2. Position the separately purchased insert as shown in figure 6. Align the holes in the insert with the holes in the clips and secure with two #4 screws.

3. Repeat the above steps for the other side facing reflector/flash tube assembly.

*C. Function Activation.*

1. Standard (Quadruple Flashing) Mode.

The standard mode in four head and six head models is activated by applying 12VDC to the control cable's heavy red wire. All models, except Model SJL2111, can also operate on 24VDC.

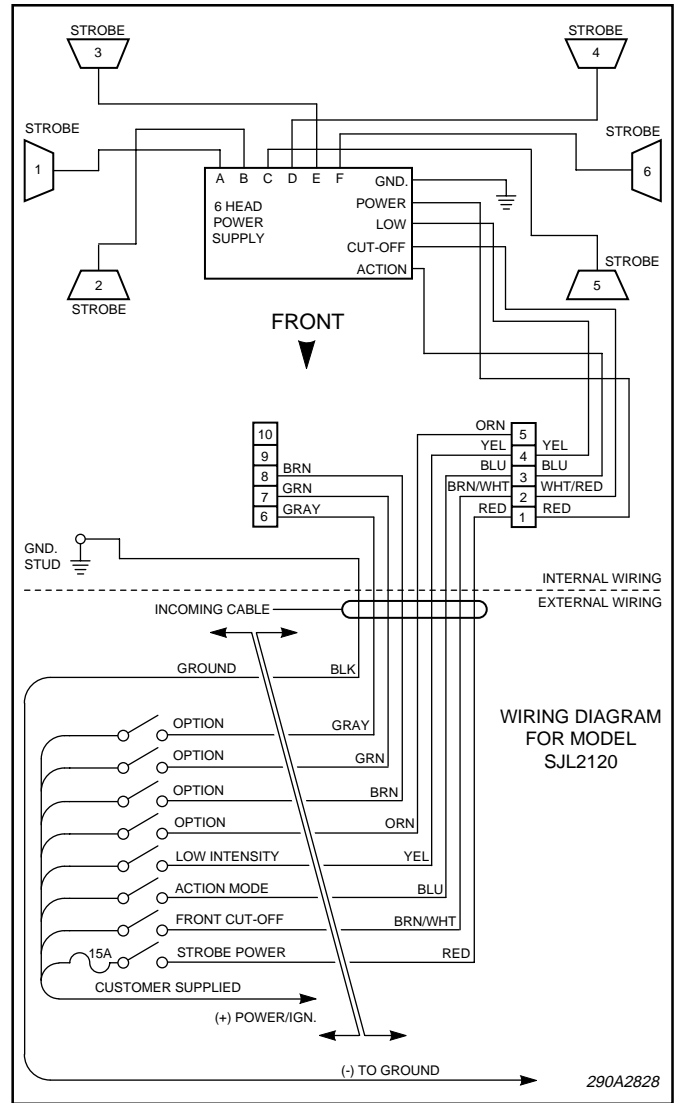

Figure 4.

2. Action Mode.

Activate the standard mode (described above), and apply 12VDC to the control cable's blue wire.

3. Front Cutoff.

Front cutoff in four and six head models is activated by applying 12VDC to the control cable's brn/white wire.

4. Low Intensity Double Flash Mode.

Activate the standard, action, or front cutoff mode (described above), and apply 12VDC to the control cable's yellow wire.

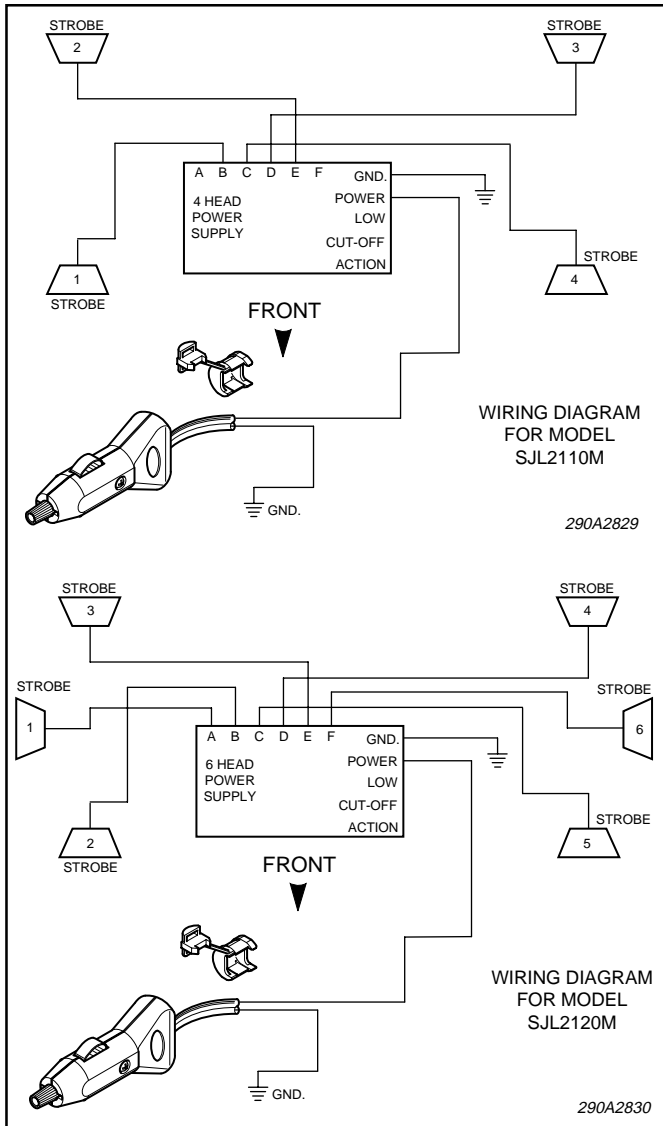

Figure 5.

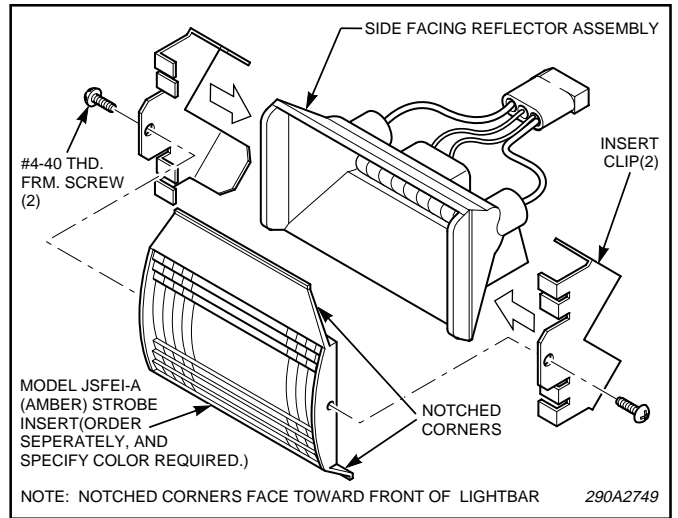

Figure 6.

#### IV. BASIC MAINTENANCE.

##### WARNING

High voltages are present inside the lightbar. Wait at least ten (10) minutes, after shutting off power, before servicing this unit. Failure to do so may result in property damage, serious injury, or death to you or others.

Disconnect ALL power to the lightbar before any maintenance is performed.

##### A. *Cleaning the Plastic Domes.*

Ordinary cleaning of the plastic domes can be accomplished by using mild soap and a soft rag. Should fine scratches or a haze appear on the domes, they can ordinarily be removed with a non-abrasive, high quality automotive paste wax.

Table 1. Electrical Connections.

Wire Color	Functions		
	<i>Model SJL2111</i>	<i>Models SJL2110, SJL2112, &amp; SJL2120</i>	<i>Models SJL2110M &amp; SJL2120M</i>
BLK	Ground (-)	Ground (-)	Ground (-)
RED	Strobe Power	Strobe Power	Strobe Power
BRN/WHT	Front Cutoff	Front Cutoff	
BLU	Action Mode	Action Mode	
YEL	Low Intensity	Low Intensity	
GRAY	Takedown	Not Used	
GRN	Right Alley	Not Used	
ORG	Left Alley	Not Used	
BRN	Not Used	Not Used	

### **WARNING**

Crazing (cracking) of domes will cause reduced effectiveness of light system. Do not use cleaning agents (which will cause crazing) such as strong detergents, solvents, or petroleum products. If crazing of domes does occur, reliability of light for emergency warning purposes may be reduced until domes are replaced.

#### *B. Halogen Lamp Replacement.*

### **WARNING**

A serious injury may result if lamp is touched when hot. Always allow lamp to cool before removing.

### **CAUTION**

Service life of lamp will be shortened if glass portion is touched. If glass has been handled, clean carefully with a grease solvent.

Replace 50-watt halogen lamps with Federal Part Number 8107A119 and 35-watt with 8548A028.

#### *C. Cleaning Reflector Assemblies.*

Use a soft tissue to clean the reflectors. Avoid heavy pressure and the use of caustic or petroleum base solvents which will scratch or dull the surface.

#### *D. Reflector/Flash Tube Assembly Replacement.*

### **WARNING**

High voltages are present inside the lightbar. Wait at least ten (10) minutes, after shutting off power, before servicing this unit. Failure to do so may result in property damage, serious injury, or death to you or others.

Disconnect ALL power to the lightbar before any maintenance is performed.

As strobe lights are used, flash tubes begin to darken, causing the light output to decrease. Also, as flash tubes age, they may have a tendency to misfire (not fire periodically).

After extended operation, occasionally check for flash tube degradation. Should the tube misfire, have a noticeable decrease in light output, glow continuously, or darken excessively, it should be replaced.

### **NOTE**

Not replacing the reflector/flash tube assembly when any of the above conditions exist could cause a break-down of other power supply components.

To replace a reflector/flash tube assembly, proceed as follows:

1. Unplug the reflector/flash tube assembly's connector from the wiring harness.
2. Remove and retain the two #8 thread-forming screws which secure the reflector/flash tube assembly.
3. Install the new reflector/flash tube assembly (Part No. 8552443) by performing the previous steps in reverse order.

#### *E. Strobe Power Supply Fuse Replacement.*

### **WARNING**

High voltages are present inside the lightbar. Wait at least ten (10) minutes, after shutting off power, before servicing this unit. Failure to do so may result in property damage, serious injury, or death to you or others.

Disconnect ALL power to the lightbar before any maintenance is performed.

Replace the fuse on the power supply's top with an exact replacement. The 15A fuse is Federal Part No. 148A142-06 and the 10A fuse is Federal Part No. 148A142-05.

#### *F. Strobe Power Supply Replacement.*

### **WARNING**

High voltages are present inside the lightbar. Wait at least ten (10) minutes, after shutting off power, before servicing this unit. Failure to do so may result in property damage, serious injury, or death to you or others.

Disconnect ALL power to the lightbar before any maintenance is performed.

Other than the fuse, the strobe light power supply does not contain any user serviceable parts. Should a breakdown in the power supply occur, it should be returned to Federal for repair and replaced. To remove the power supply, proceed as follows:

1. Unplug the connectors from the power supply.
2. Remove the four #8 screws which secure the power supply.
3. Install the new power supply by performing the previous steps in reverse order.

## V. INSERT LAYOUT.

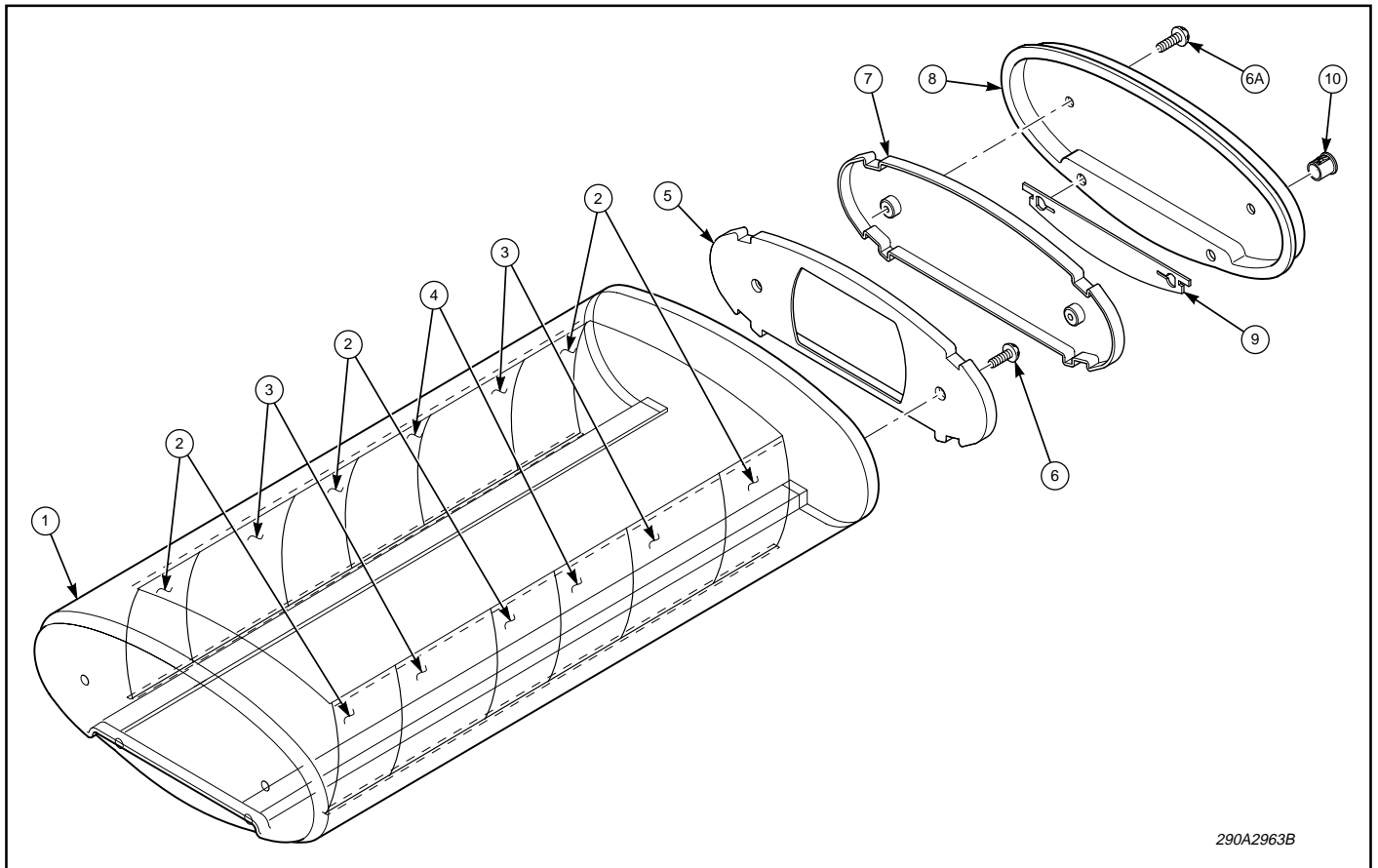

Figure 7.

Item No.	Description	Part No.	SJL 2110P	SJL 2110PM	SJL 2111P	SJL 2112P	SJL 2120P	SJL 2120PM
1	Dome, Clear	8552D054B	1	1	1	1	1	1
2	Insert, Clear	JSHI-C						
	Insert, Red	JSHI-R						
	Insert, Amber	JSHI-A	6	6	6	6	6	6
	Insert, Blue	JSHI-B	AR	AR	AR	AR	AR	AR
	Insert, Green	JSHI-G						
3	Insert, Clear	JSFI-C						
	Insert, Red	JSFI-R						
	Insert, Amber	JSFI-A	4	4	4	4	4	4
	Insert, Blue	JSFI-B	AR	AR	AR	AR	AR	AR
	Insert, Green	JSFI-G						
4	Insert, Center, Clear	JSCL-C						
	Insert, Center, Red	JSCL-R						
	Insert, Center, Amber	JSCL-A	2	2	2	2	2	2
	Insert, Center, Blue	JSCL-B	AR	AR	AR	AR	AR	AR
	Insert, Center, Green	JSCL-G						
	Insert, Center, Black	JSCL-BK						
5	Insert, Dome End, Red (With Hole)	JSIECA*R			2	2	2	2
	Insert, Dome End, Amber (With Hole)	JSIECA*A	0	0	AR	AR	AR	AR
	Insert, Dome End, Blue (With Hole)	JSIECA*B						
6	Screw, #4-24 x 5/16" Type B, Phillips Pan Hd.	7011A014-05	2	2	2	2	2	2
6A	Screw, Mach., #8-32 x 1/2" Slotted Rd. Hd.	7000A063-08	2	2	2	2	2	2
7	Insert, Dome End, Red	JSIEC*R						
	Insert, Dome End, Amber	JSIEC*A	2	2	0	0	0	0
	Insert, Dome End, Blue	JSIEC*B	AR	AR				
	Insert, Dome End, Green	JSIEC*G						
8	Endcap, Dome	8552286A	1	1	1	1	1	1
9	Gasket, Endcap	8552B047B-01	1	1	1	1	1	1
10	Plug, Hole	231162A	2	2	2	2	2	2