

**INSTRUCTION SHEET  
FOR  
MODELS MS1-FD, MS2-FD, MS1-LUM97, AND MS2-LUM97**

**SAFETY MESSAGE TO INSTALLERS**

People's lives depend on your safe installation of our products. It is important to read, understand and follow all instructions shipped with the products. In addition, listed below are some other important safety instructions and precautions you should follow:

- To properly install this light: you must have a good understanding of automotive electrical procedures and systems, along with proficiency in the installation and use of safety warning equipment.
- DO NOT install equipment or route wiring or cord in the deployment path of an air bag.
- When drilling into a vehicle structure, be sure that both sides of the surface are clear of anything that could be damaged.
- In order for the light to function properly, a separate ground connection must be made. If practical, it should be connected to the negative battery terminal. At a minimum, it may be attached to a solid metal body or chassis part that will provide an effective ground path as long as the light system is to be used.
- Locate light control so the VEHICLE and CONTROL can be operated safely under all driving conditions.
- Do not attempt to activate or deactivate light control while driving in a hazardous situation.
- You should frequently inspect the light to ensure that it is operating properly and that it is securely attached to the vehicle.
- File these instructions in a safe place and refer to them when maintaining and/or reinstalling the product.

Failure to follow all safety precautions and instructions may result in property damage, serious injury, or death to you or others.

**A. GENERAL.**

The Federal Mirror Strobe Models MS1 and MS2 are high intensity, directional strobe light heads. They are designed for use with Federal Model SPS2 (two head power supply) or Model SPS4 (four head power supply). These power supplies will provide 75 double strobe flashes with flash energy of 10 joules per double flash.

The units are supplied with a mounting bracket which allows a flexible mounting arrangement. Lens colors

(amber, red, blue, or clear) are specified when ordering. The lenses are interchangeable, and can be ordered separately.

**B. UNPACKING.**

After unpacking the light, inspect it for damage that may have occurred in transit. If the unit has been damaged, do not attempt to install or operate it. File a claim immediately with the carrier, stating the extent of damage. Carefully check all envelopes, shipping labels, and tags before removing or destroying them. Ensure that the parts listed in the appropriate KIT CONTENTS LIST are included in the package.

**C. KIT CONTENTS LIST.**

Qty.	Description	Part No.
1	Screw, #6-32 x 1	7000A400-16
4	Screw, Hex Hd., 1/4 x 5/8	7011165-10
2	Screw, Torx Pan Hd., 1/4 x 5/8	7011161-10
1	Lockwasher, Split, #6	7074A007
2	Lockwasher, Ext. Tooth, 1/4	7075078
1	Bolt, Carriage, 1/4-20, MS1	7004A020-08
1	Bolt, Carriage, 1/4-20, MS2	7004A020-12
1	Nut, 1/4-20	7059A020
1	Nut, #6-32	7059A005
1	Washer, Flat, 1/4	7072A024
1	Washer, Flat, #6	7072A007
2	Washer, Flat, 1/4, Black	7072230
1	Lockwasher, Split, 1/4	7074A016
1	Gasket, Rubber, MS1	8240A107
2	Gasket, Rubber, MS2	8240A107
1	Bracket, Mounting, Ford	8573091
1	Bracket, Bail, MS1	8573090
1	Bracket, Bail, MS2	8573125
1	Mirror, Rear View	8573097
1	Adhesive Pad	8573199

**WARNING**

This product is intended for supplemental warning and for use in conjunction with an approved primary warning light system. This strobe head can be powered by several types of strobe power supplies. Consult local codes and regulations to determine if the power supply/strobe head combination complies.

**D. INSTALLATION.**

**WARNING**

When installing equipment inside air bag equipped vehicles, the installer MUST ensure that the equipment is installed ONLY in areas recommended by the vehicle manufacturer.

Failure to observe this warning will reduce the effectiveness of the air bag, damage the air bag, or potentially damage or dislodge the equipment, causing serious injury or death to you or others.

**CAUTION**

Vehicle damage may result from improper removal of vehicle's interior rear view mirror. Read and follow the safety precautions and instructions contained in the vehicle's service manual(s).

1. Remove and retain the interior rear view mirror by performing the removal instructions contained in the vehicle's service manual(s).

2. See figure 1. Locate the roof support channel(s) under the headliner. Using the mounting bracket as a template, align four mounting holes with the support channel(s) and mark four drill position marks on the mounting surface.

**CAUTION**

Before drilling holes in ANY part of a vehicle, be sure that both sides of the mounting surface are clear of parts that could be damaged; such as electrical wiring or other vital parts.

3. Drill four 0.194" mounting holes at the previously marked drill position marks.

4. See figure 2. Remove the release liner from one side of the adhesive pad and secure the pad to the mounting bracket in the location shown. Remove the release liner from the other side of the adhesive pad and secure the rear view mirror in the mounting bracket's small slot using the #6-32 x 1" pan head screw, #6 flat washer, #6 lockwasher and #6 nut.

5. Secure the mounting bracket/mirror assembly to the mounting surface using the four 1/4" x 5/8" hex head type B screws.

6. See figure 3. Assemble the bail bracket to the light assembly using the two 1/4" x 5/8" pan head screws, external tooth lockwashers, and black flat washers. Do not tighten the screws at this time. Cut the rubber gaskets to length and assemble to the sides of the light assembly as shown in figure 3.

7. See figure 3. Assemble the light assembly/bail bracket to the mounting bracket's center slot using the 1/4-20 carriage bolt, flat washer, split lockwasher, and 1/4-20 nut. Do not tighten the nut at this time.

**WARNING**

Do not install the light in a location which can obstruct the driver's vision. Installing the light assembly too low will obstruct the driver's vision and prevent safe vehicle operation. Ensure that the light is mounted in a position that allows maximum visibility.

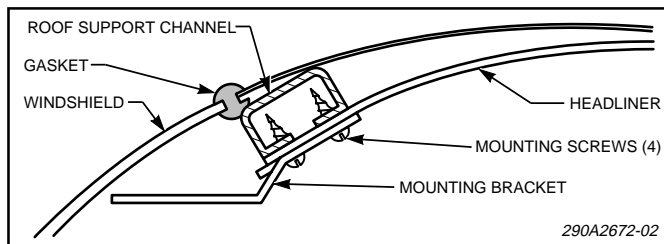

Figure 1.

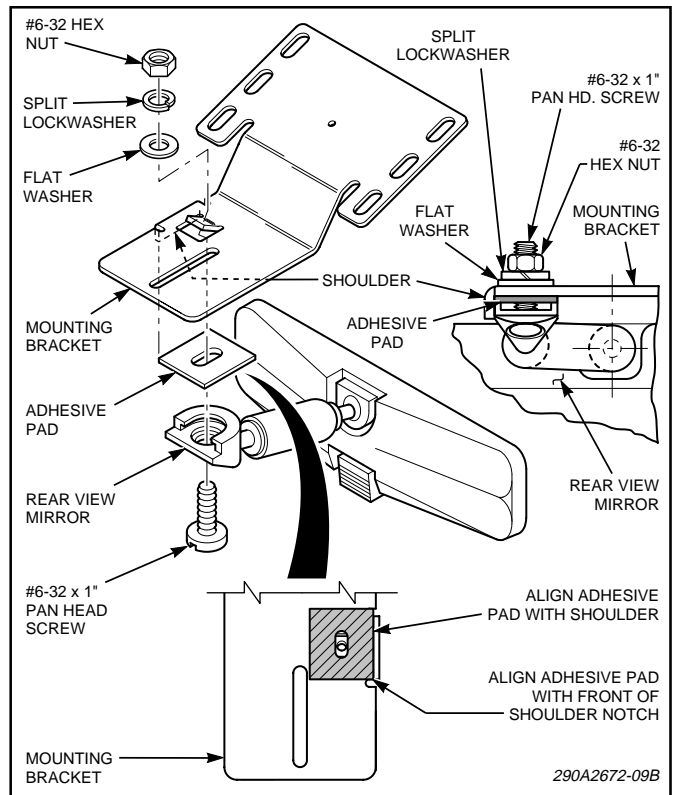

Figure 2.

**CAUTION**

Do not install the light assembly in the windshield's tinted area. Light output will be reduced and the light's color will change, lessening the effectiveness of the light.

8. Position a 1/8" thick cardboard spacer between the windshield and the light assembly. Adjust the light assembly housing so that it is parallel to the road surface, and is just below the tinted portion of the vehicle's windshield. Tighten all fasteners and remove the cardboard spacer.

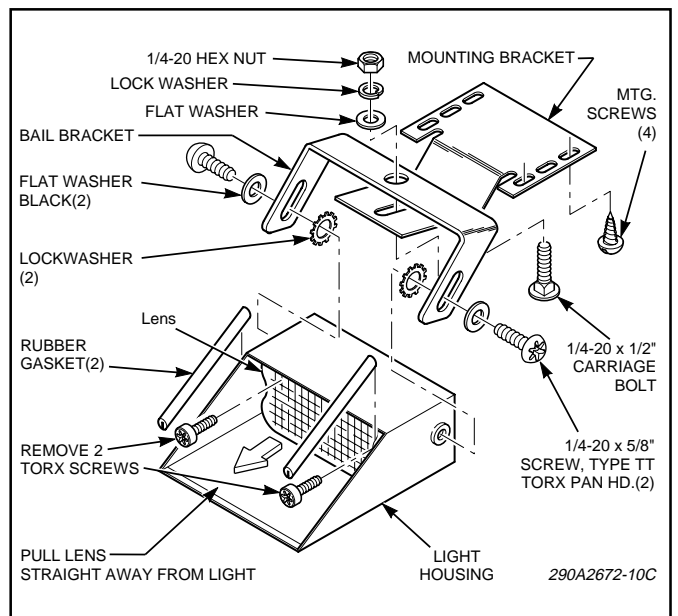

Figure 3.

## WARNING

Blind spots will result if the interior rear view mirror is improperly installed. Position the replacement rear view mirror as close as possible to the position of the original rear view mirror.

## E. ELECTRICAL.

### CAUTION

The strobe tube assembly is designed to be used exclusively with Federal Signal's Model SPS2/SPS4 power supplies and SPC16 or SPC30 cable kits. Use of any other power supply may cause shortened service life of the strobe tube.

### WARNING

High voltages are present in a strobe light system. Cover any unused power supply connector slot(s) with electrical tape.

The light assemblies are supplied with a 3-foot cable with terminals. Perform the electrical connections as described in the instructions packed with the power supply and the cable kit. Test the unit for proper operation.

### NOTE

One cable kit is required for installation of one-head units. Two cable kits are required for installation of two-head units

## F. MAINTENANCE.

### 1. General.

### WARNING

Crazing (cracking) of lenses will cause reduced effectiveness of the light. Do not use cleaning agents (which will cause crazing) such as strong detergents, solvents, or petroleum products. If crazing of lenses does occur, reliability of light for emergency signaling purposes may be reduced until lenses are replaced.

Ordinary cleaning of the plastic lenses can be accomplished by using mild soap and a soft rag. Should fine scratches or a haze appear on a lens, they can ordinarily be removed with a non-abrasive, high quality, one-step, automotive paste cleaner/wax and a soft cloth.

### 2. Strobe Tube Replacement.

### WARNING

High voltages are present in a strobe light system. Wait at least five (5) minutes, after shutting off power, before servicing the unit. Failure to do so may result in property damage, serious injury, or death to you and others.

a. Disconnect all power to the strobe system power supply before performing any maintenance.

b. Remove and retain the two screws and lockwashers which secure the light assembly to the mounting bracket (see figure 3).

c. See figure 4. Remove and retain the screws which secure the visor to the mounting bar.

d. Disconnect the quick connect terminals from the defective strobe tube.

e. Remove the strobe tube assembly by pulling the wires at the base of the strobe tube assembly. Pull the strobe tube straight away from the mounting bar.

### CAUTION

Service life of strobe tube will be shortened if glass is touched. If glass has been handled, clean carefully with a grease solvent.

f. See figure 5. SLOWLY insert the new strobe tube in the mounting bar until it is properly seated in the top slot of the strobe tube. If the strobe tube is difficult to insert, remove it and apply a high temperature grease, or Vaseline, to the rubber edge of the strobe tube and try again.

g. Reconnect the quick connect terminals. Reassemble the unit.

h. Reconnect all power connections to the power supply and test for proper operation.

### NOTE

Figure 6 shows Model MS2's internal wiring.

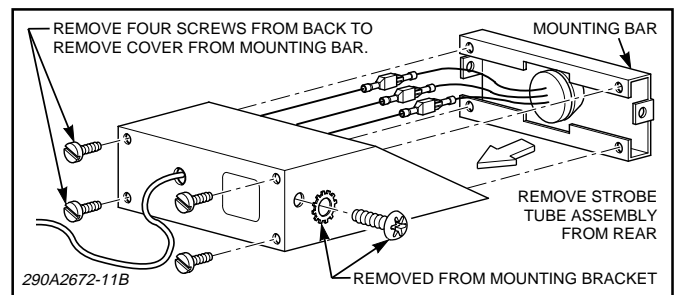

Figure 4.

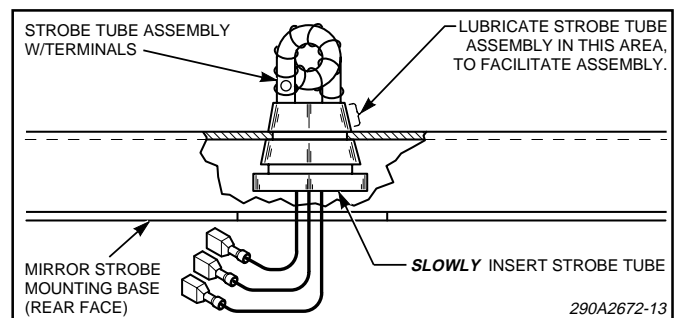

Figure 5.

## SAFETY MESSAGE TO OPERATORS

Peoples' lives depend on your safe use of our products.

Listed below are some important safety instructions and precautions you should follow:

- Although your warning system is operating properly, it may not be completely effective. People may not see or heed your warning signal. You must recognize this fact and continue driving cautiously.
- Also, situations may occur which obstruct your warning signal when natural or man-made objects are between your vehicle and others, such as: raising your hood or trunk lid. If these situations occur, be especially careful.
- At the start of your shift, you should ensure that the light is securely attached and operating properly.

Failure to follow these safety precautions may result in property damage, serious injury, or death to you, to passengers, or to others.

**RETAIN AND REFER TO THIS MESSAGE**

## G. REPLACEMENT PARTS LIST.

Description	Part No.
Strobe Tube Assembly	8575013
Cable Assy., 3-cond., MS1	175762
Cable Assy., 4-cond., MS2	175765
Bracket, Bail, MS1	8573040B
Bracket, Bail, MS2	8573125
Reflector, Strobe	8573187
Lens, Red	8573001-01
Lens, Blue	8573001-03
Lens, Amber	8573001-02
Lens, Green	8573001-04
Screw, Pan Hd., Torx, #8	7011163-04

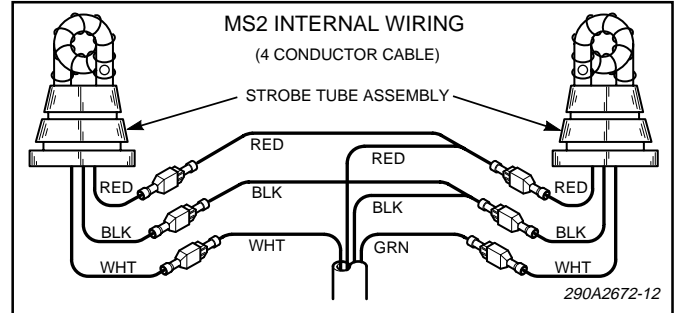

Figure 6.