

Informer100 Speaker Series C

Models IS-I-IP100AC and IS-I-IP100DC
High-Powered, Indoor/Outdoor, Audible Speaker



Signaling Standalone Manual

Limited Warranty

This product is subject to and covered by a limited warranty, a copy of which can be found at www.fedsig.com/SSG-Warranty. A copy of this limited warranty can also be obtained by written request to Federal Signal Corporation, 2645 Federal Signal Drive, University Park, IL 60484, email to info@fedsig.com or call +1 708-534-3400.

This limited warranty is in lieu of all other warranties, express or implied, contractual or statutory, including, but not limited to the warranty of merchantability, warranty of fitness for a particular purpose and any warranty against failure of its essential purpose.



FEDERAL SIGNAL Safety and Security Systems

2645 Federal Signal Drive
University Park, Illinois 60484

www.fedsig.com

Customer Support 1-800-344-4634 • +1-708-534-4756
Technical Support 1-800-755-7621 • +1-708-587-3587

All product names or trademarks are properties of their respective owners.

Contents

Safety Messages	5
Safety Messages to Installers	5
General Description	7
Introduction	7
Features.....	7
Ordering Information	8
Specifications	10
Installation	12
Determine a Suitable Location.....	12
Wall Mounting	12
Attaching the Mounting Brackets to the Speaker Housing.....	13
Pole Mounting	15
Mounting with Omni Direction Bracket (2-3/8 inch diameter pole).....	17
Mounting without Bracket.....	18
Opening the Housing	19
Wiring Power to the Control Board	19
Wiring to the Relay/Electronic Outputs	22
Wiring to the Alarm Initiation Input Connections	22
Using Optional Warning Lights.....	22
Ethernet Port.....	25
Relay Outputs	25
Configuring the Speaker	25
Closing the Housing.....	25
Programming	26
Automatic Volume Level Control.....	26
Digital Inputs	26
WAV Files.....	26
Function Control Commands	27
Configuring Informers Using the Web Interface	27
Ordering Replacement Parts	48
Getting Service	49
Appendix A Standard DV Messages	50

Figures

Figure 1 PS Series Push Button Stations (optional).....	9
Figure 2 Informer100 Speaker with 225XL light.....	9
Figure 3 Bracket attached to speaker.....	13
Figure 4 Width and height of bracket	13
Figure 5 Depth and height with bracket	14
Figure 6 Top view of speaker	14
Figure 7 Ceiling mount.....	15
Figure 8 Bracket IS-I-IP100-PMW	15
Figure 9 Bracket IS-I-IP100-PM.....	16
Figure 10 Bracket IS-I-IP100-OMNI.....	17
Figure 11 Surface mount hole center dimensions	18
Figure 12 Opening speaker	19
Figure 13 DC Controller Board.....	20
Figure 14 AC Controller Board.....	21
Figure 15 FB2PST Strobe with Informer100 Speaker.....	23
Figure 16 151XST Strobe with Informer100 Speaker	24
Figure 17 225XST/225XL Strobe with Informer100 Speaker	24

Tables

Table 1 Ordering Information	8
Table 2 Optional Accessories.....	8
Table 3 Electrical	10
Table 4 Visual Indications (Located on internal control board.)	10
Table 5 Connectors and Jacks (Control board connectors)	11
Table 6 Environmental and Physical	12
Table 7 Alarm Initiation Inputs (JP5).....	22
Table 8 Input and Output Configuration	26
Table 9 Examples of Illegal WAV Files.....	27
Table 10 Replacement Parts	48
Table 11 Standard DV Messages.....	50
Table 12 UTM Tones	58

Safety Messages

⚠ WARNING

It is important to follow all instructions shipped with this product. This device is to be installed by trained personnel who are thoroughly familiar with the country's electric codes and will follow these guidelines as well as local codes and ordinances, including any state or local noise-control ordinances.

Planning

- Warning devices or procedures may be needed to effectively warn people indoors.
- The sound output of sirens is capable of causing permanent hearing damage. To prevent excessive exposure, carefully plan siren placement, post warnings, and restrict access to areas near sirens. Review and comply with any local or state noise control ordinances as well as OSHA noise exposure regulations and guidelines.

After installation, service, or maintenance, test the system to confirm that it is operating properly. Test the system regularly to confirm that it will be operational in an emergency.

Safety Messages to Installers

People's lives depend on your safe installation of our products. It is important to follow all instructions shipped with this product. This device is to be installed by a trained electrician who is thoroughly familiar with the National Electrical Code and/or Canadian Electrical Code and will follow the NEC and/or CEC Guidelines as well as all local codes.

The selection of the mounting location for this Informer100 Speaker, its controls, and the routing of the wiring is to be accomplished under the Facilities Engineer and the Safety Engineer direction. Listed below are some other important safety instructions and precautions you should follow:

- Electrocutation or severe personal injury can occur when performing various installation and service functions such as making electrical connections, drilling holes, or lifting equipment. Therefore, only experienced electricians should install this product per national, state, and any other electrical codes having jurisdiction. Perform all work under the direction of the installation or service crew safety foreman.
- Read and understand all instructions before installing, operating, or servicing this equipment.
- All effective warning sounds may, in certain circumstances, cause permanent hearing loss. Take appropriate precautions, such as wearing hearing protection. The maximum sound level exposure limits specified in OSHA 29 CFR 1910 should not be exceeded.
- For optimum sound distribution, do not install this speaker where objects would block any portion of the front of the Informer100 Speaker.
- Do not paint the Informer100 Speaker. No finish or coating is required. Paint may obstruct the sound output, reducing the effectiveness of the horn.
- Establish a procedure to check the signal system for proper activation and operation routinely.
- Any maintenance to the unit **MUST** be performed by a trained electrician per NEC Guidelines and local codes.

Safety Messages

- Never alter the unit in any manner.
- The nameplate should NOT be obscured, as it contains cautionary and/or other information of importance to maintenance personnel.
- After installation and completion of the initial system test, provide a copy of these instructions to all personnel responsible for the operation, periodic testing, and maintenance of the equipment.
- File these instructions in a safe place and refer to them when maintaining and/or reinstalling the device.

Failure to follow all safety precautions and instructions may result in property damage, serious injury, or death.

Installation and Service

- After installation or service, test the system to confirm that it is operating properly. Test the system regularly to confirm that it will be operational in an emergency.
- If future service and operating personnel do not have these instructions to refer to, the system may not provide the intended audible warning, and service personnel may be exposed to death, permanent hearing loss, or other bodily injuries. File these instructions in a safe place and refer to them periodically. Give a copy of these instructions to recruits and trainees. Give a copy to anyone who is going to service or repair the Informer100 Speaker.
- To reduce the risk of electric shock, do not perform any servicing other than what is contained in the operating instructions unless you are qualified to do so. Refer all servicing to qualified service personnel. Always test the Informer100 Speaker before using after repairs have been made.

Ethernet Wiring

- Unless shielded or run in conduit, Ethernet wiring must be at least six feet from bare power wiring or lightning rods and associated wires, and at least six inches from other wire (for example, antenna wires, doorbell wires, wires from transformers to neon signs), steam or hot water pipes, and heating ducts.
- Do not place Ethernet wiring or connections in any conduit, outlet, or junction box containing high voltage electrical wiring.
- If using a cable gland, gland must be Listed. The Informer100 Speaker has 3/4-inch and 1/2-inch NPT entry sizes.

Symbol Definition

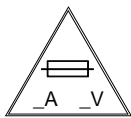

Indicates to reduce the risk of fire, replace the fuse as marked.

Pay careful attention to the notice located on the equipment.

Read and understand the information contained in this manual before attempting to install or service the siren.

General Description

Introduction

The Informer100 Speaker is an indoor and outdoor 100-watt speaker. Use the Informer100 as a warning and alert device with both audible and visual indicators. The audible capabilities include locally stored, high-quality, high-powered tones and voice. The visual indicators include the use of strobes, lights, and beacons. The Informer100 can be equipped with up to four local initiation devices (switches) to activate the unit locally.

The Informer100 Speaker has an internal 100-watt amplifier/driver to deliver tone warnings and intelligible voice messages from Informer100 stored memory.

The Informer100 allows connection of up to four external switches to activate predefined alert events. The Informer100 can be programmed and configured as a standalone device to only use the inputs to activate the Informer100. This may be useful if the location has no network connectivity, but where voice and tone alerts from locally activated inputs are required.

The Informer100 includes a relay output, a DC solid-state relay output, and an AC solid-state relay output for controlling strobes or other devices. The Informer100 has a 1/2-inch NPT opening on the top of the speaker for simple installation of pipe mount devices. The bottom of the speaker has three 3/4-inch NPT openings to allow access to power, LAN, relay outputs, and activation inputs.

The Informer100 is designed for outdoor use and large indoor structures. It can be powered from 120 or 240 Vac or 24 Vdc depending on the model purchased. All wiring interfaces are accessible via internal connectors and built-in NPT entrances for quick and easy installation.

The Informer100 comes with an adjustable stainless steel wall mount bracket that allows the angle of the speaker to be adjusted. Optional pole mount brackets are available for small and large diameter poles.

Features

The Informer100 has the following features; some features require the use of the Commander[®] software system:

- High-powered outdoor or indoor IP-enabled speaker for audible and visual alerts
- Speaker rated at 120 dBa for tones and 114.5 dBa for voice at 10 feet
- Out-of-the-box standard programming. Changes to the configuration can be made using our web interface found on www.fedsig.com.
- Out-of-the-box configuration (All modes are maintained and normally open)
 - Tone 1 – NFPA Temporal Coded Slow Whoop
 - Tone 2 – Alternating High-Low
 - Tone 3 – Rapid Siren (Yelp)
 - Tone 4 – Steady Horn (Euro-Toxic)

General Description

- Seven standard built-in warning signals: Wail, Steady, Alternate Wail, Alternate Steady, Pulsed Wail, Pulsed Steady, Auxiliary Chime
- Broadcasts prerecorded voice or tone files
- Deliver intelligible voice messages from locally prerecorded files
- Prerecorded files: 4000 voice or tone messages with 17 hours of total recording time
- Ambient noise level monitoring with automatic volume control
- Individually configured for volume and noise-level adjustments
- Wall or pole mount options
- Four local alarm initiation inputs to activate the unit locally or standalone operation
Momentary mode: contact closure sounds alarm for the programmed duration.
Continuous mode: sounds alarm for the duration of the closure.
- Relay outputs to control strobes or other devices (See page 22 for warning lights information.)
- 120/240 Vac or 24 Vdc powered (two models)
- Wide outdoor temperature operating range

Ordering Information

Table 1 Ordering Information

Part Numbers	Description
IS-I-IP100DC	24 Vdc 100 watt wall mount
IS-I-IP100AC	120/240 Vac 100 watt wall mount
IS-I-IP100-PM	Small (6-inch or less) Pole Mount Bracket
IS-I-IP100-PMW	Large (over 6-inch) Pole Mount Bracket
IS-I-IP100-OMNI	Omni Directional Option for IP Speaker

Table 2 Optional Accessories

Part Numbers	Description
PSEV-Y	Indoor Yellow Station – Push and Turn Reset Button “EVACUATION”
PSEVSC-Y	Indoor Yellow Station – Push and Turn Reset Button “EVACUATION,” with Sounder Cover
PSEM-R	Indoor Red Station – Push and Turn Reset button “EMERGENCY”
PSEMSC-R	Indoor Red Station – Push and Turn Reset button “EMERGENCY,” with Sounder Cover
225XL-024X ^{1,2}	Hazardous Location LED Light 24 Vdc
225XL-120-240X ^{1,2}	Hazardous Location LED Light 120-240 Vac

¹ “X” Indicates color: (A) Amber, (B) Blue, (C) Clear, (G) Green, and (R) Red

² The light is powered from the same source as the speaker

The following figure illustrates the wall-mounted buttons for activation.

Figure 1 PS Series Push Button Stations (optional)



The following is a picture of the Informer100 Speaker shown with optional 225XL Warning Light.

Figure 2 Informer100 Speaker with 225XL light

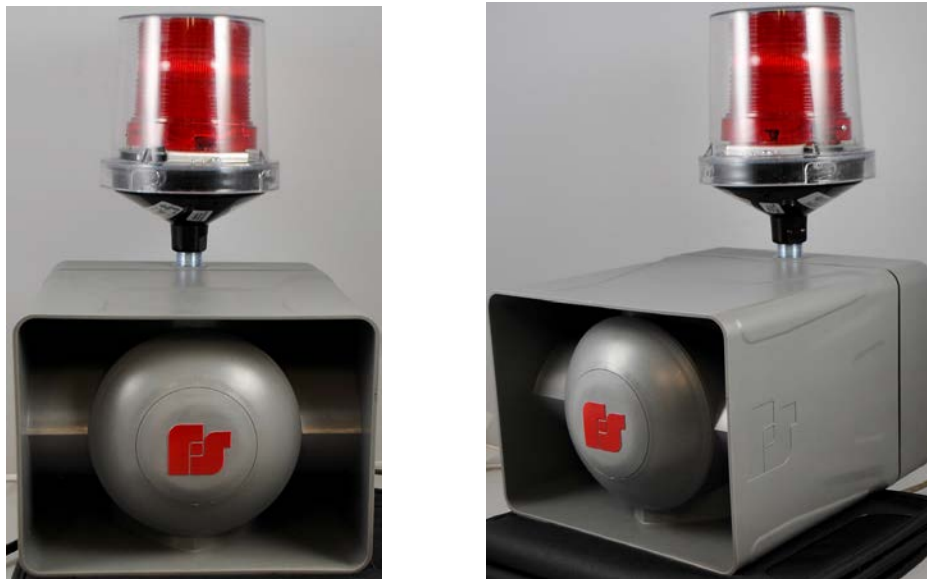

Specifications

Table 3 Electrical

Operating Voltages IS-I-IP100AC Switch-selectable 120 or 240 Vac	120 Vac nom, 50/60 Hz or 240 Vac nom, 50/60 Hz
Operating Current IS-I-IP100AC	120 Vac; 26 mA Standby, 1.50 A during a function, 4.50 A during a function if relays are fully loaded. 240 Vac; 21 mA Standby, 820 mA during a function, 3.82 A during a function if relay outputs are fully loaded.
Operating Voltages IS-I-IP100DC	24 Vdc nominal
Operating Current IS-I-IP100DC	24 Vdc; 100 mA Standby, 5.15 A during a function, 12.15 A during a function if relay outputs are fully loaded.
Relay Outputs	Mechanical relay output 2 A at 30 Vdc or 250 Vac, 25 A max inrush, N.O. dry contacts. DC solid-state relay output 5 A at up to 28 Vdc current limited. AC solid-state relay output 1 A at 20 to 264 Vac zero crossing switched.
Ethernet Port	IEEE 802.3, 10/100 Base-T connection
Alarm Initiating Inputs	Four optically Isolated Inputs Dry Contact closure < 1 kilohm NOTE: The four optically isolated Alarm Initiation Inputs allow remote activation of tones and messages through a volt-free, dry-contact closure. The momentary contact closure must be a minimum of 500 ms.
Audio Storage	Warning siren audio, seven factory installed tones: Wail, Steady, Alternate Wail, Alternate Steady, Pulsed Wail, Pulsed Steady, Auxiliary Chime Prerecorded files—up to 4,000 voice or tone messages with 17 hours of total recording time
Audio Data	8 bit 8 kHz mono wave (G7.11 μ -law)
Audio Frequency response	300 Hz to 3000 Hz, +1 to -3 dB per octave
Maximum Audio Output	100 watts, 120 dBa tones/114.5 dBa for voice at 10 feet

The following indicators are for troubleshooting purposes only. These indicators are not visible when the unit is closed.

Table 4 Visual Indications (Located on internal control board.)

POWER	Green LED turns on when power is connected. (D5)
ISOLATED POWER	Green LED turns on when Isolated power for inputs and relay outputs is functioning. (D6)
CPU	Flashing RED LED indicates the CPU is running its program. (D18)
NETWORK	Green LED turns on when unit has made a connection to the network. (D27)
LISTEN	Red LED turns on when Commander® is listening. Unit is sending audio to Commander. (D25)

TALK	Green LED turns on when Commander is talking. Unit is playing audio being sent. (D26)
AMPOUTPUT VOLTAGE	Green LED turns on when amplifier is active. Brightness indicates level of amplifier output. (D2)
AMPLIFIER OUTPUT CURRENT	Green LED turns on when amplifier is active. Brightness indicates level of amplifier output. (D8)
ACTIVATION INPUT #1	Red LED turns on when Activation input #1 is being activated. (D13)
ACTIVATION INPUT #2	Red LED turns on when Activation input #2 is being activated. (D15)
ACTIVATION INPUT #3	Red LED turns on when Activation input #3 is being activated. (D19)
ACTIVATION INPUT #4	Red LED turns on when Activation input #4 is being activated. (D20)

Table 5 Connectors and Jacks (Control board connectors)

JP2	Serial Port for factory approved programming or for message board display
JP3 Pin Jack	Reserved for factory testing
JP4 Relay Outputs	1 and 2 mechanical relay Normally Open 3 – DC solid-state relay, (+) DC power 4 – DC solid-state relay, Switched (+) DC power to strobe or light 5 – AC solid-state relay 6 – AC solid-state relay NOTE: Mechanical relay output is programmed as Relay 1. Solid-state relays are programmed as Relay 2.
JP5 Initiation inputs	1 and 2 – ISO Ground/Input 1 3 and 4 – ISO Ground/Input 2 5 and 6 – ISO Ground/Input 3 7 and 8 – ISO Ground/Input 4 NOTE: Each input is activated by shorting the two pins associated with the input.
JP6, JP7, JP8, and JP9 AC or DC Power Distribution	1 – L1/Hot/(+) 24 Vdc 2 – L2/Neutral/(-) 24 Vdc Gnd 3 – Earth Ground NOTE: JP6, JP7, JP8 and JP9 are physically connected to provide a distribution of AC or DC power. The combined load of all power should not exceed 8 amperes AC/DC, 25 A max inrush
JP10	Reserved for factory testing
JP11	Short to restore factory default settings
JP12	Reserved for factory testing

Table 6 Environmental and Physical

Operating temp range	-40°F to 150°F (-40°C to +66°C) at 20% duty cycle. Continuous duty UL rating: -40°F to 104°F / (-40°C to 40°C).
Humidity range	0-95%, non-condensing
Size (Height x Width x Length)	7 x 9 x 10 inches (17.8 x 22.9 x 25.4 cm)
Weight I-IP100DC I-IP100AC	16.2 lb (7.35 kg) 19.2 lb (8.71 kg)

Installation

⚠ WARNING

Read and adhere to all safety warnings in this manual before installing the Informer100 Speaker.

⚠ DANGER

ELECTROCUTION HAZARD: Electrocution or severe personal injury can occur when making electrical connections, drilling holes, or lifting equipment. Therefore, experienced electricians, per national and local electrical codes, acting under the direction of the installation crew safety foreman, should perform the installation.

Determine a Suitable Location

The Informer100 can be mounted on any relatively flat surface with the supplied mounting brackets. The mounting surface must be capable of supporting the weight of the speaker.

Wall Mounting

The Informer100 Speaker comes standard with a bracket for vertical wall or pole mount with optional pole accessories. The standard mount can be flipped to allow ceiling mount.

To wall mount the Informer100 Speaker:

1. Find a suitable location to mount the speaker. Use industry- or company-preferred practices when mounting hardware to structures.
2. Verify that the mounting is adequate to hold the weight of the speaker, cables, and visual devices if equipped.
3. Refer to Figure 3 or use the U-shaped wall bracket as a template to scribe the mounting hole locations.
4. Mount the Informer100 Speaker to the mounting surface with user-supplied hardware. Federal Signal recommends 3/8-inch fasteners.
5. Loosen the pivot bolts to provide the direction of the speaker.

Attaching the Mounting Brackets to the Speaker Housing

To attach the brackets:

1. The mounting brackets are attached to the speaker as shown in Figure 3 using the six supplied 1/4-20 by 5/8 inch screws.

Note the orientation of the curved slots on the L-shaped brackets; this orientation is important for the speaker to pivot downward.

2. Tighten the 1/4-20 by 5/8 inch screws to approximately 80 in-lb.
3. Attach the U-shaped wall bracket with four supplied sets of 3/8-16 by 1-inch bolts, flat washers, lock washers, and nuts.

Figure 3 Bracket attached to speaker

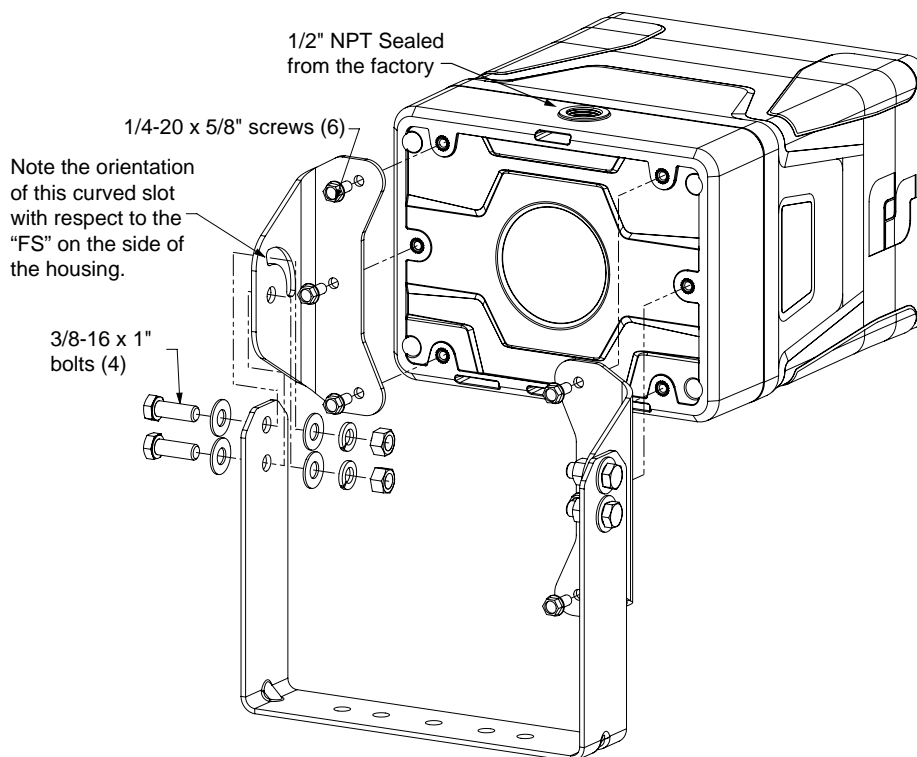

Figure 4 Width and height of bracket

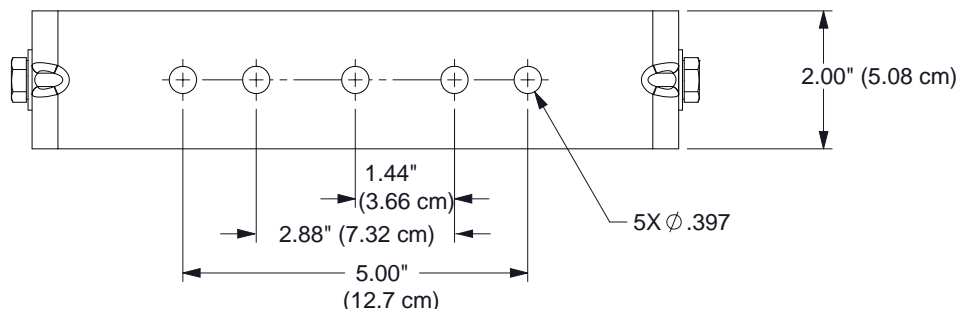

Figure 5 Depth and height with bracket

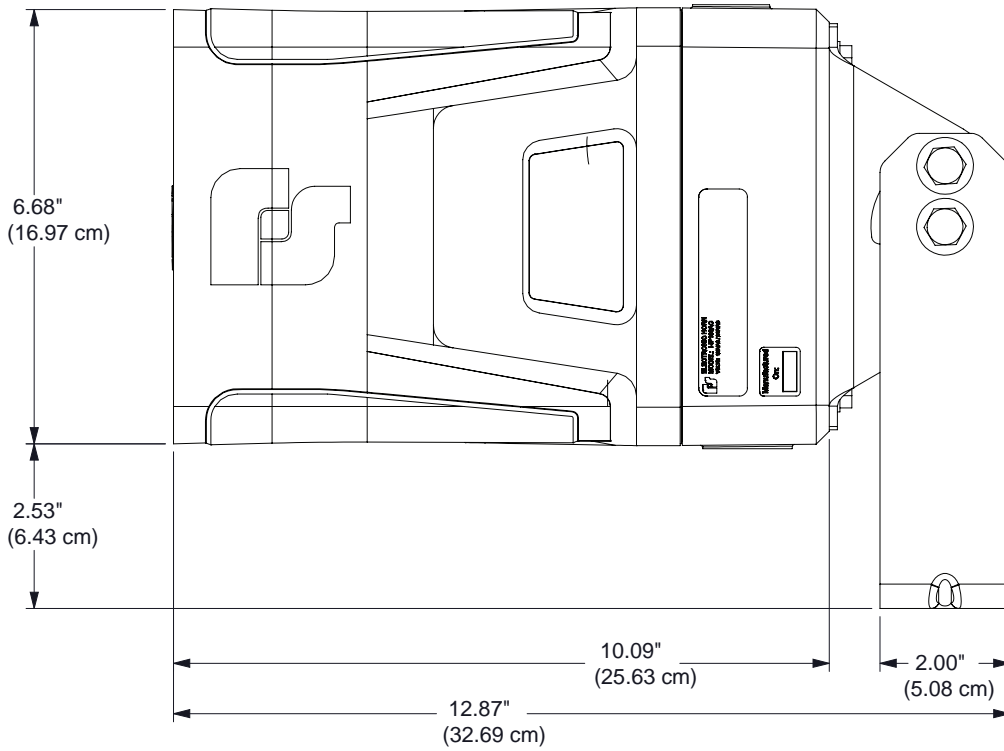

Figure 6 Top view of speaker

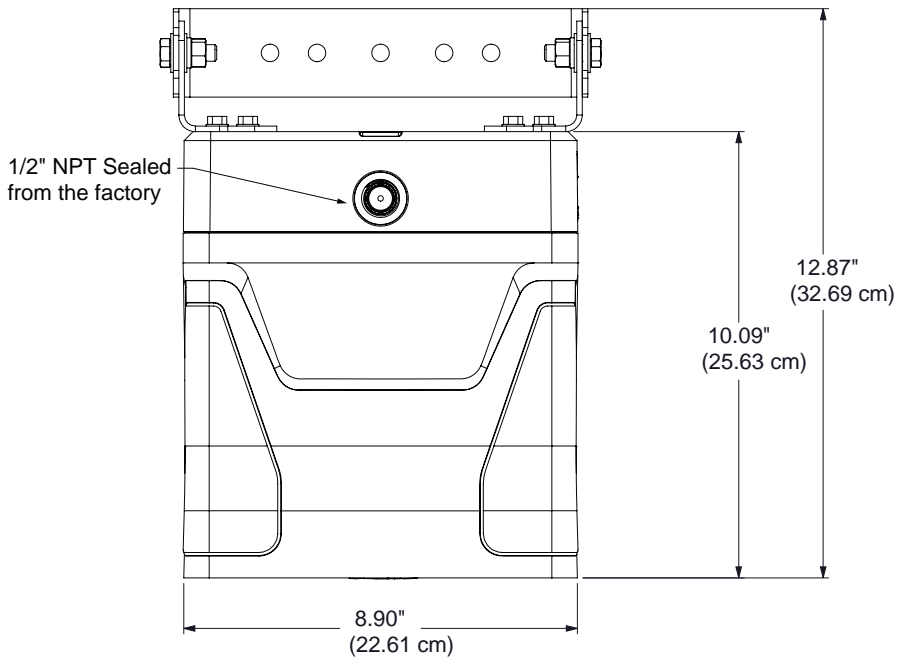
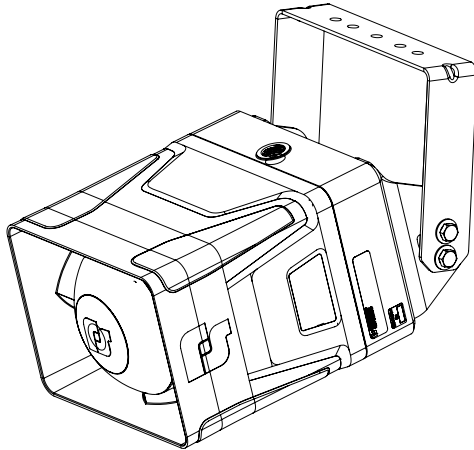

Figure 7 Ceiling mount

Pole Mounting

The Informer100 comes standard with a bracket for vertical wall or pole mount with optional pole accessories.

Large Pole Mounting (6-inch diameter or larger)

Use the following procedure if mounting the speaker with the optional I-IP100-PMW bracket:

1. Find a suitable location to mount the speaker. Use industry- or company-preferred practices when attaching hardware to poles or other structures.
2. Attach the IS-I-IP100-PMW bracket to the pole using banding or use the predrilled holes to bolt the bracket to the pole or structure.
3. Using the supplied flat washers, lock washers, and 3/8-inch nuts, mount the speaker to the IS-I-IP100-PMW bracket as shown in Figure 2.
4. Use the side-pivot bolts to allow adjustment of the speaker up and down to optimize speaker effectiveness.

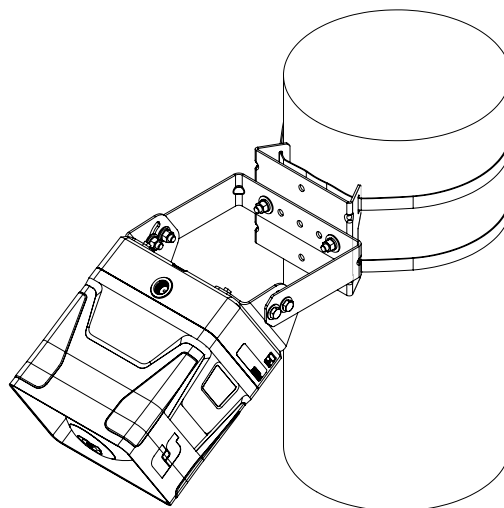
Figure 8 Bracket IS-I-IP100-PMW

Small Pole Mounting (2-3/8 inch or 4-1/2 inch diameter poles)

Use the following procedure if mounting the speaker with the optional IS-I-IP100-PM bracket:

1. Find a suitable location to mount the speaker. Use industry- or company-preferred practices when attaching hardware to poles or other structures.
2. Remove the speaker U-shaped bracket; store the pivot/lock bolts.
3. Select the proper IS-I-IP100-PM U-bolt for the pole.
4. Attach the U-shaped bracket from the speaker to the pole using the IS-I-IP100-PM U-bolt, bracket, nuts, and washers.
5. Attach the speaker and set the direction using the pivot and lock bolts.

Figure 9 Bracket IS-I-IP100-PM

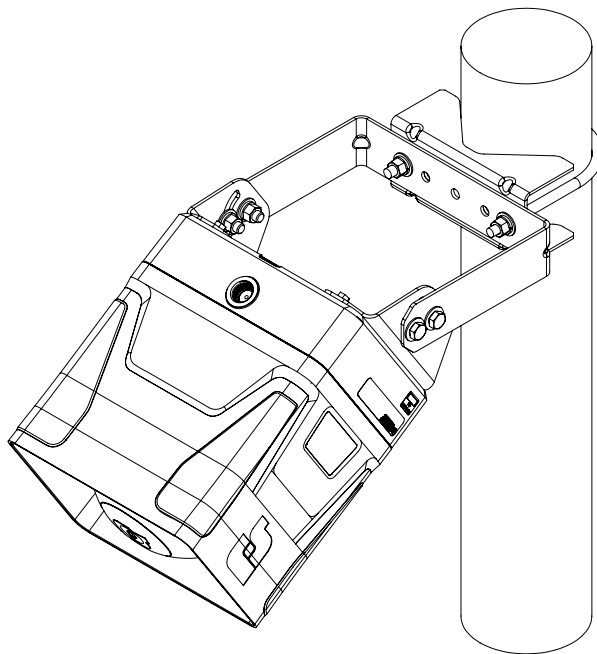
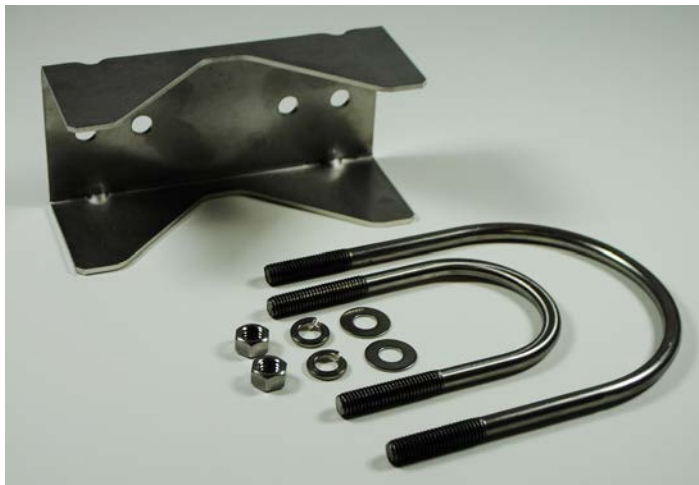

Mounting with Omni Direction Bracket (2-3/8 inch diameter pole)

Use the IS-I-IP100-OMNI bracket to create an omni-directional speaker. The speaker is mounted as described in the Small Pole Mount section with the omni bracket mounted at a distance of 2.0 inches from the speaker.

Use the following procedure if mounting the speaker with the optional IS-I-IP100-OMNI bracket:

1. Identify the desired location for the bracket.
2. Attach the bracket using the supplied U-bolts and hardware.

Figure 10 Bracket IS-I-IP100-OMNI

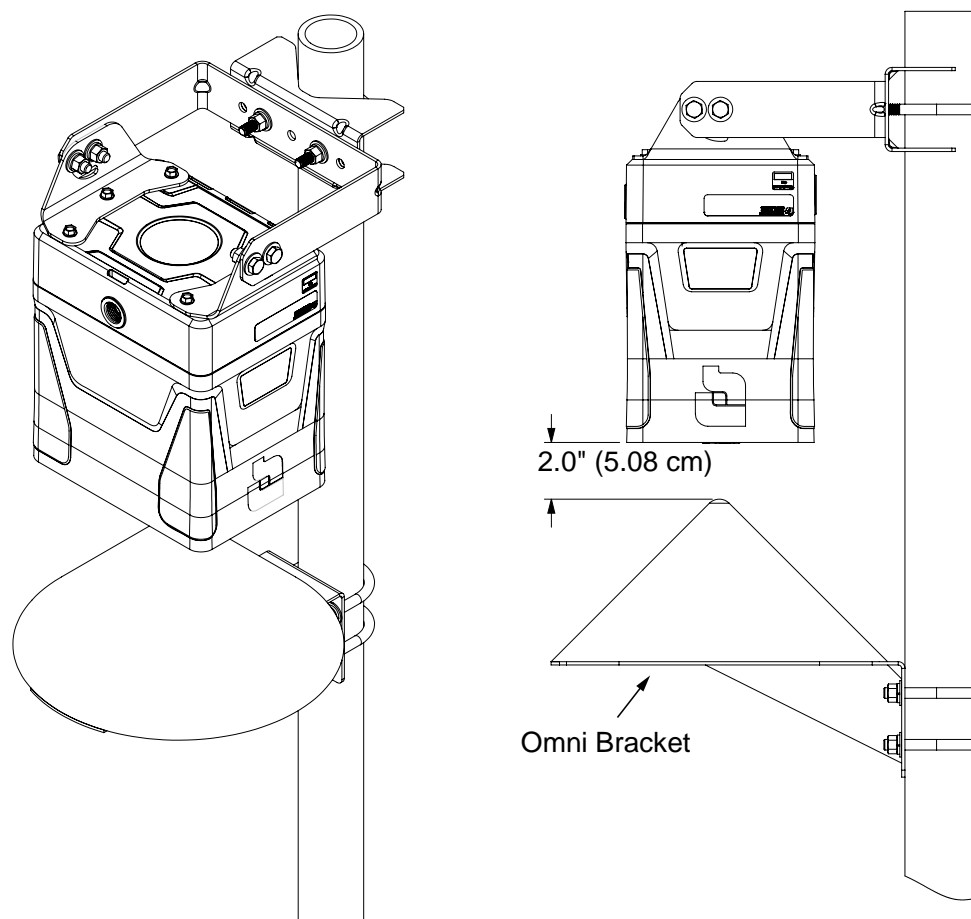

Mounting without Bracket

You can mount the speaker directly to the mounting surface without the bracket. Use installer-supplied 1/4-20 fasteners that are suitable for the mounting surface. See Figure 11 for the hole center dimensions.

Figure 11 Surface mount hole center dimensions

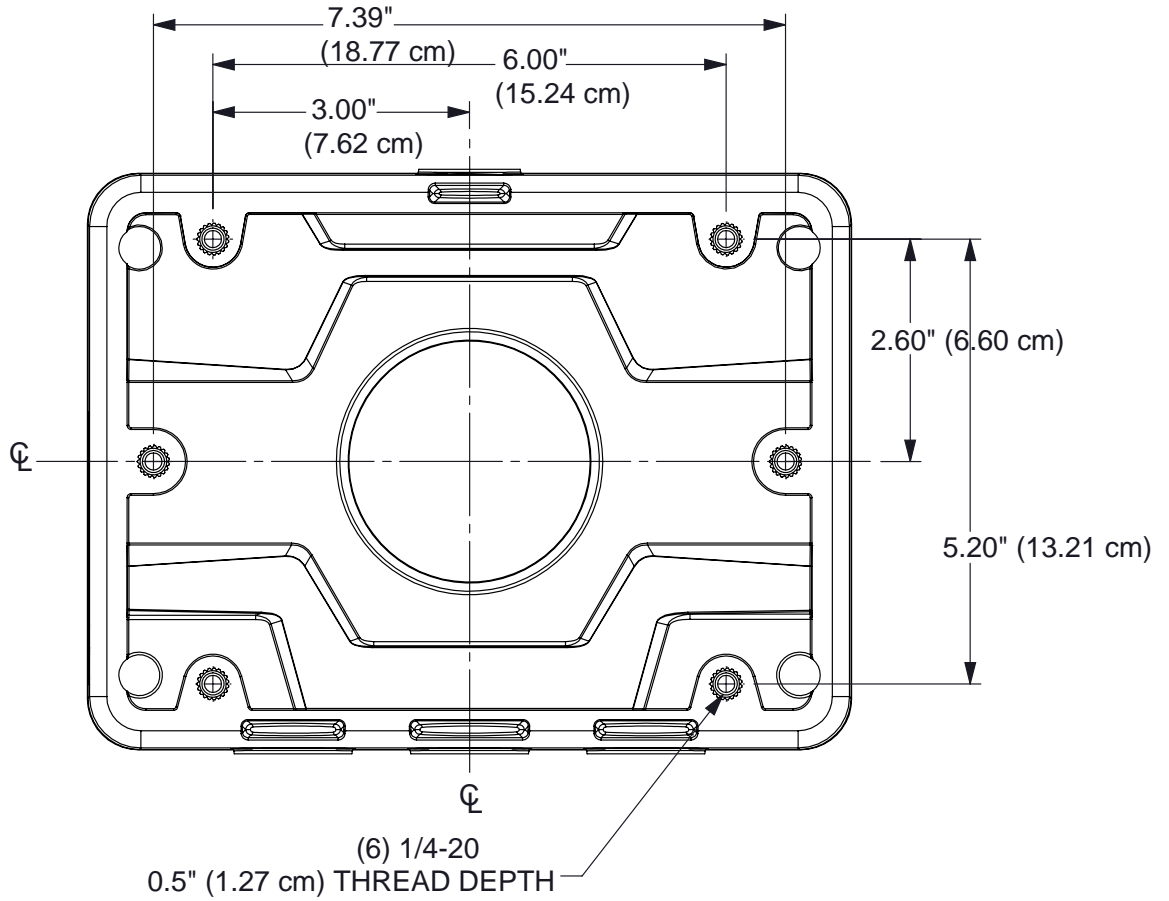

Opening the Housing

Tools required:

- 3/8-inch socket
- 6-inch extension

To open the housing, loosen the four cover screws while supporting the housing so it does not fall. (The cover screws are retained in the housing.) The front of the unit is heavy, but it is attached to the rear housing with a pivot hinge to allow ease of service. If the unit requires service, replace the front housing, amplifier, and power supply (if equipped) as an entire unit.

Figure 12 Opening speaker

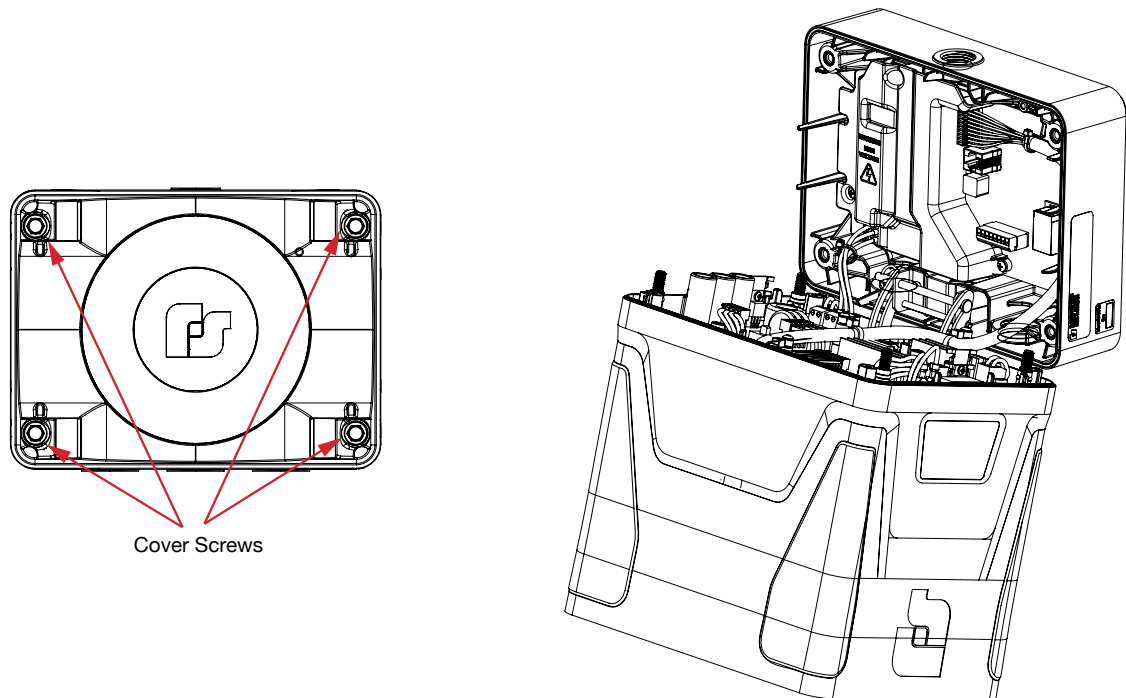

Wiring Power to the Control Board

JP6, JP7, JP8, and JP9 are all connected in parallel. Federal Signal recommends using JP8 as the AC or DC input to allow room for wires coming in from the 3/4-inch NPT opening. When power is supplied to JP8, it is connected through the PCB to the other three connectors. If a connector is not being used, it is recommended to leave the connector on the PCB. With IS-I-IP100AC units, JP9 is wired from the factory to the power supply PCB. With the IS-I-IP100DC units, JP9 is wired to the amplifier PCB. Use JP6 and JP7 to wire external lights or strobes through JP4. A typical installation would use voltage to be wired through the JP4 relays contacts or solid-state relay outputs.

NOTE: Current draw from JP6, JP7, and JP4 must not exceed 8.5 amperes AC or 5.0 ampere DC Max Combined Load.

IS-I-IP100DC 24Vdc Model

- JP4 is used for relay 1 (pins 1 and 2) and provides an interface for DC powered strobes using (pins 3 and 4).
- JP6 and JP7 can be used for access to 24 Vdc to power strobes or other external equipment.
- JP8 is used for incoming +24 Vdc power.
- JP9 is prewired to the amplifier.

Figure 13 DC Controller Board

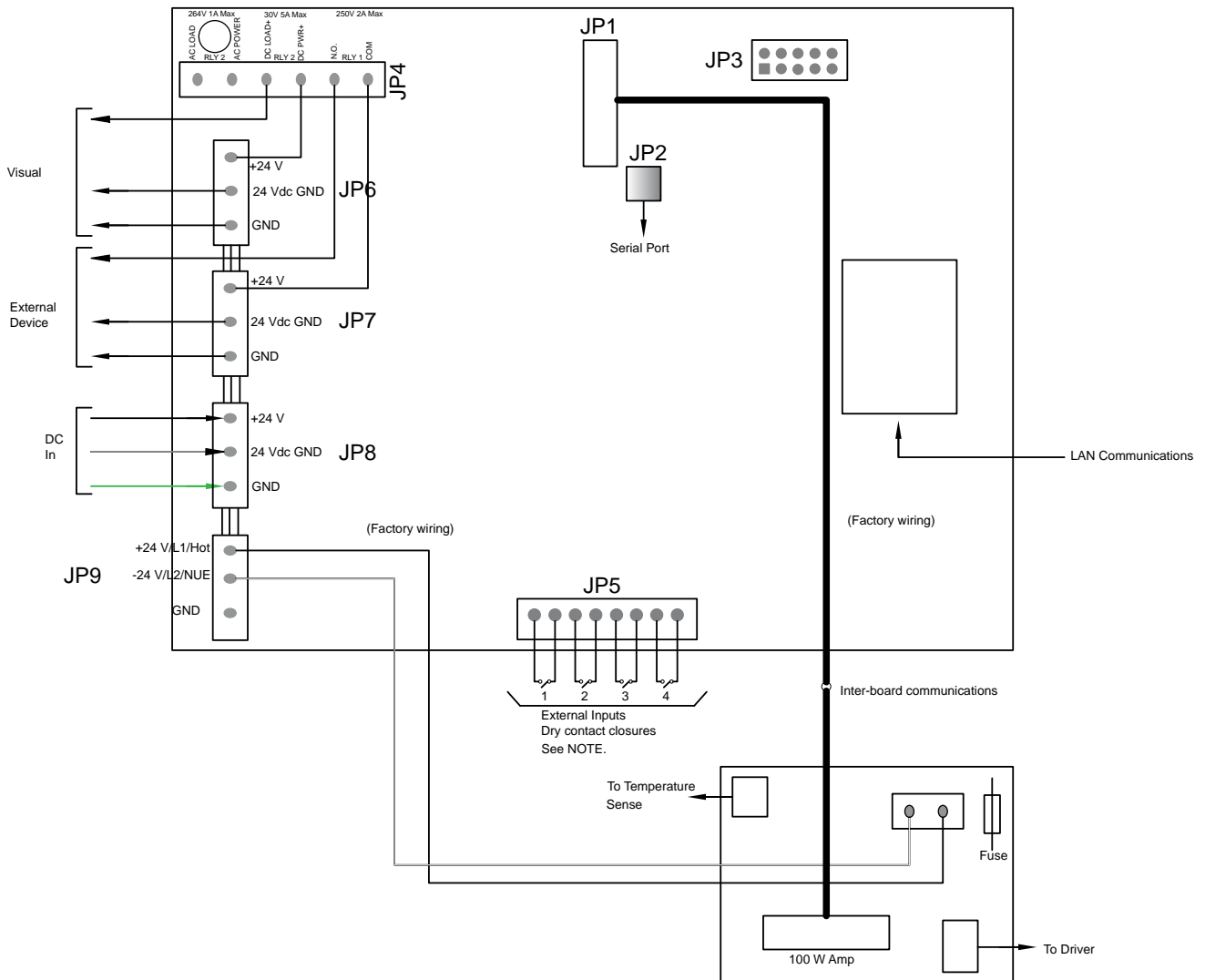

IS-I-IP100AC 120/240 Vac Model

- JP4 is used for relay 1 (pins 1 and 2) and provides an interface for AC powered strobes using (pins 5 and 6).
- JP6 and JP7 can be used for access to 120 or 240 Vac to power strobes or other external equipment.
- JP8 is used for incoming AC power. Verify switch on the power supply is set correctly.
- JP9 is prewired to the power supply.

Figure 14 AC Controller Board

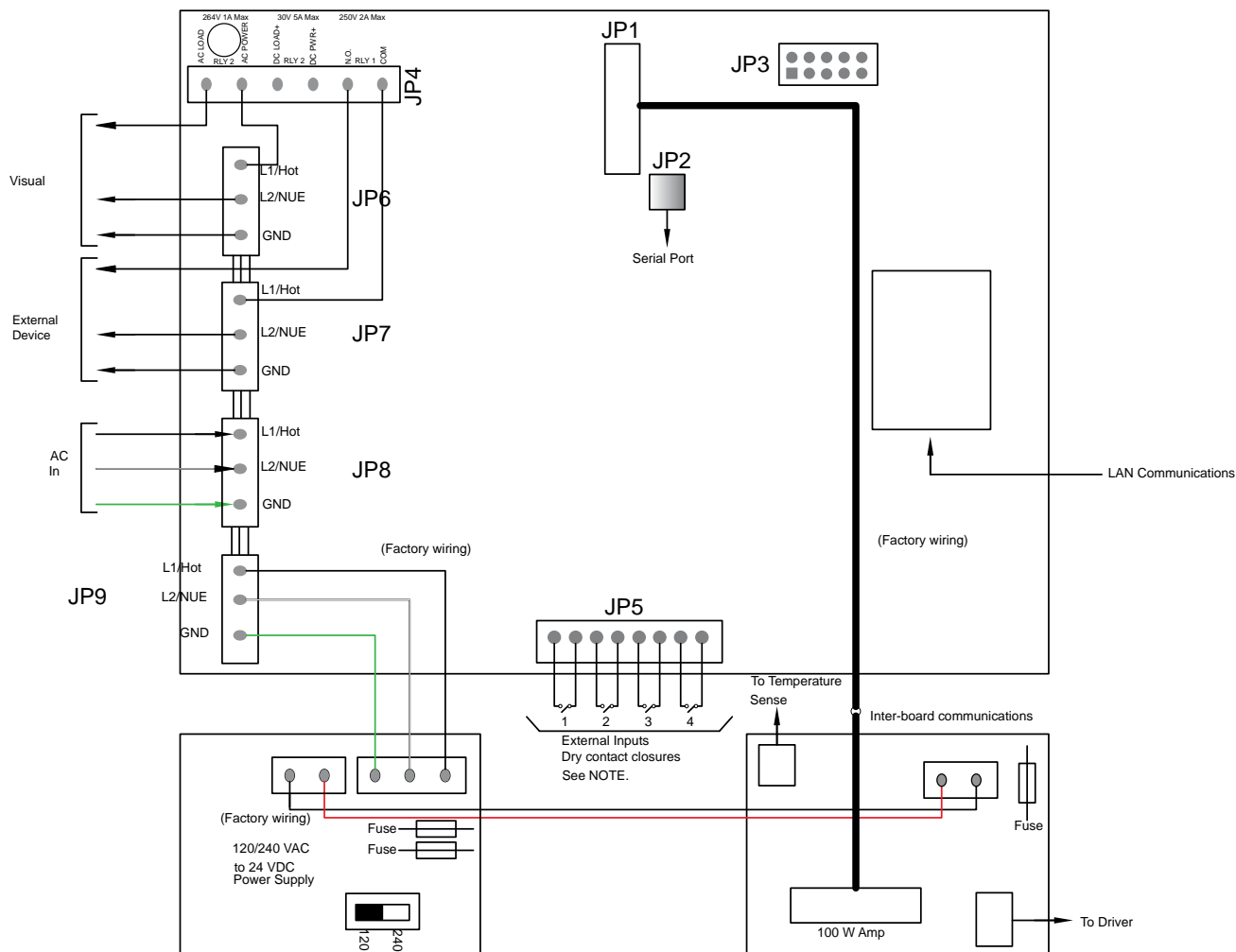

Wiring to the Relay/Electronic Outputs

JP4 – Relay Outputs

1 and 2 mechanical relay Normally Open.

3 – DC solid-state relay, (+) DC power.

4 – DC solid-state relay, Switched (+) DC power to strobe or light.

5 – AC solid-state relay power

6 – AC solid-state relay load

Wiring to the Alarm Initiation Input Connections

The Alarm Initiation Inputs are activated by shorting the input to the ISO-GND next to it, usually through a normally open switch or normally open dry relay contact.

NOTE: Momentary mode: contact closure sounds alarm for the typical programmed duration. Continuous mode: sounds alarm for the duration of closure. The system can also be configured to allow activation from normally closed contacts.

Table 7 Alarm Initiation Inputs (JP5)

Alarm Initiation Inputs (JP5)	1	2	3	4
Isolated Ground	Pin 1	Pin 3	Pin 5	Pin 7
Input	Pin 2	Pin 4	Pin 6	Pin 8

Using Optional Warning Lights

Warning lights, such as strobes, often have a high inrush current that may damage mechanical relays. A solid-state relay has been implemented to handle these high input current devices. Use the DC solid-state relay for DC warning lights (pins 3 and 4 of JP4). See Figure 13 on page 20. Use the AC solid-state relay for AC warning lights (pins 5 and 6 of JP4). See Figure 14 page 21. An external current-limiting resistor is not required with the solid-state relay.

See the following list of Federal Signal DC powered warning lights that may be controlled by the IP100:

- 121A Vitalite® Rotating Warning Light
- 121X Explosion-Proof Rotating Light
- 191XL Hazardous Location Division Listed LED Warning Light
- FB2LED Fireball® LED Warning Light
- FB2LEDX Fireball Hazardous Location LED Warning Light
- 225XL Electraray® Hazardous Location LED Flashing Warning Light
- FB2PST Fireball Strobe Warning Light
- 225XST and 225XST-I Electraray Hazardous Location Strobe Warning Light
- 151XST Hazardous Location Warning Light

See the following list of Federal Signal AC powered warning lights that may be controlled by the IP100:

- 121S Vitalite® Rotating Warning Light
- 225 Electraray® Rotating Warning Light
- 225X Electraray Hazardous Location Rotating Warning Light
- 371LED Commander® LED Rotating Warning Beacons
- 371LEDX Hazardous Location Commander® LED
- FB2LED Fireball® LED Warning Light (single- and quad-color models)
- FB2LEDX Fireball Hazardous Location LED Warning Light (single- and quad-color models)
- 191XL Hazardous Location Division Listed LED Warning Light
- 225XL Electraray Hazardous Location LED Flashing Warning Light
- FB2PST Fireball Strobe Warning Light
- 225XST and 225XST-I Electraray Hazardous Location Strobe Warning Light
- 151XST Hazardous Location Warning Light

Figure 15 FB2PST Strobe with Informer100 Speaker

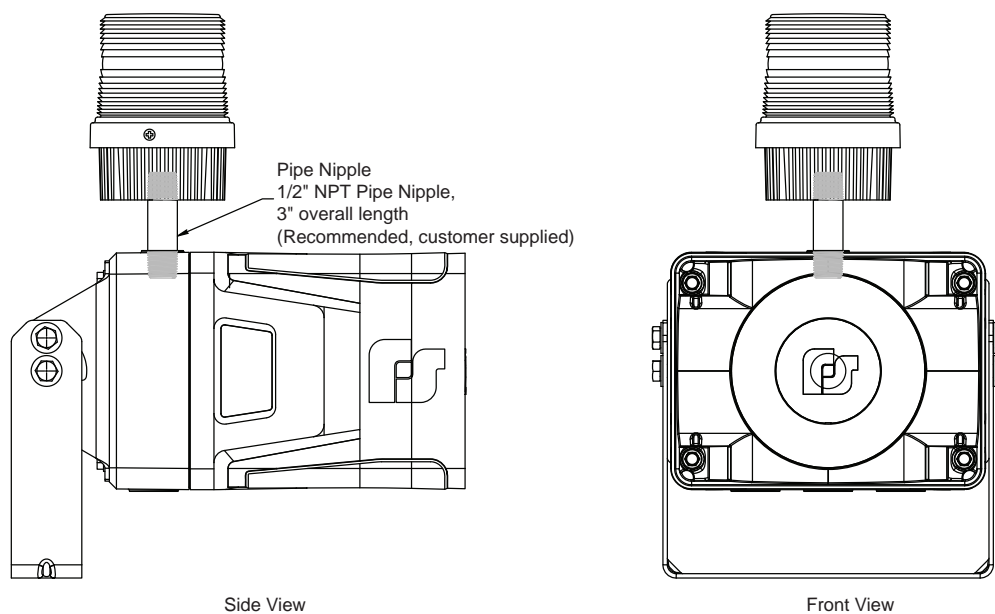

For a FB2PST Strobe, the following is recommended (customer supplied): 1/2-inch NPT Pipe Nipple (3 inches overall length).

Figure 16 151XST Strobe with Informer100 Speaker

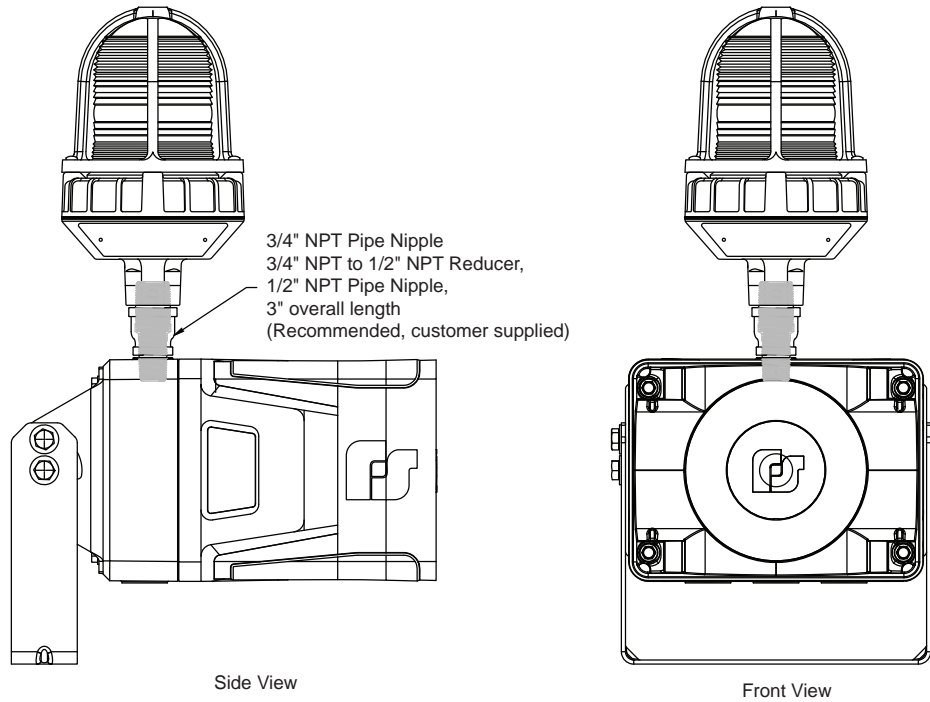

For a 151XST Strobe, the following is recommended (customer-supplied):

- 1/2-inch NPT Pipe Nipple
- 3/4- to 1/2-inch NPT Reducer
- 3/4-inch NPT Pipe Nipple (3 inches overall length)

Figure 17 225XST/225XL Strobe with Informer100 Speaker

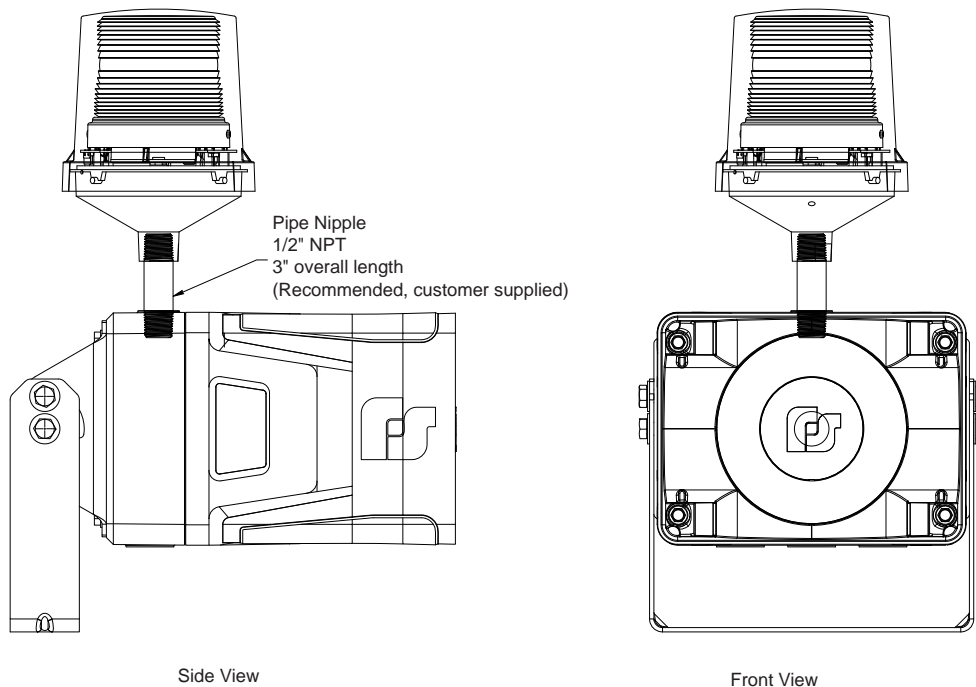

For a 225XST/225XL Strobe, the following is recommended (customer supplied): 1/2-inch NPT Pipe Nipple (3 inches overall length).

Ethernet Port

The Informer100 Speaker has an eight-pin Ethernet port for connecting to the network. Ethernet wire runs must be less than 328 feet from the nearest network switch. Do not install in a conduit carrying high voltage. The wired Ethernet port auto-negotiates a 10/100, full or half-duplex connection.

Relay Outputs

The Informer100 Speaker has two independently programmable relay outputs. Programming for relay output 1 operates the mechanical relay. Programming for relay output 2 operates both the DC solid-state relay and the AC solid-state relay. Configure the relay outputs by either using the Informer100 web pages or with the Commander software application.

The relay outputs are capable of controlling external devices. The outputs are located at pins 1 and 2, pins 3 and 4, and pins 5 and 6 of the removable output connector JP4 on the controller board. The outputs can be wired in series with the power wired into the unit by using the power connections available on JP6 and JP7, providing switched AC or DC power to activate other devices.

Do not exceed the voltage and current ratings listed in the specifications section of this manual. When using this feature, the relay outputs turn on until one of the following occurs:

- The programmed default timeout occurs
- The CANCEL or RESET command is received

You can individually configure the relay outputs to open, close, and cycle based on a pre-programmed sequence. Relays can also be configured to turn on when PA VOIP is active.

Configuring the Speaker

Perform Informer100 Speaker configuration before installing.

Closing the Housing

To close the housing:

1. Verify that the cover gasket is in the groove around the perimeter of the rear cover.
2. If the front of the unit was removed, lift the front of the Informer100 to allow the hinge pin to be installed, align the front unit with the rear cover, and attach the hinge pin with retaining clip.
3. Attach the cable between the amplifier and rear cover IP PCB. Secure the cable using the two screw-down cable ties inside the rear cover.
4. On IS-I-IP-100AC—Attach the power cable from the rear cover IP PCB to the power supply.
On IS-I-IP-100DC—Attach the power cable from the rear cover IP PCB to the amplifier.
5. Turn on the power to verify that the lights on the IP PCB are functioning. If the environment does not allow powering, proceed to the next step.

6. Verify that all connectors are seated. Also verify that wires are not strained and are not impeding the ability to close unit.
7. Lift the front of the unit and seat the front cover against the rear enclosure.
8. Tighten the cover screws hand tight, and then torque them in an alternate pattern to 60 in-lb +/- 10 in-lb.

Programming

Automatic Volume Level Control

The Informer speakers can be configured to automatically adjust the speaker's output level when the local ambient noise level changes. Configure the maximum level and ambient attenuation settings on the Informer's web page.

Digital Inputs

The Informers have digital inputs that can be activated using a dry contact closure. Configure the inputs from the Informer's web page. See "2. Configuring the RTU Settings" on page 32. Each input can be configured to play 1-19 WAV files when the input is activated. The WAV files to be played are entered by index number in a comma-separated list, for example, 1,2,6. Relay outputs can be selected to close when the input is active and remains closed until the associated WAV file(s) have finished playing.

The inputs can be configured for normally open or normally closed contacts and assigned a priority level of 1 to n (n = number of inputs available in the product). The inputs can be configured for momentary or continuous operation, or they can be disabled. Momentary inputs will play the associated WAV file one time when the state changes to active. Continuous configured inputs will continue to play the associated WAV files and open or close associated relay output(s) as long as the input is active. If multiple continuous inputs are active, the WAV files and relay outputs associated with each input will activate in sequence. Lower priority inputs are ignored while higher priority inputs are active. If an equal or greater priority momentary input is activated while a continuous input is active, the momentary input will interrupt the WAV file and relay controls associated with the continuous input. The continuous input(s) will resume control when the WAV file(s) associated with the momentary input finish playing. Equal or higher priority momentary inputs will override other active momentary controls.

Web page configurations must be applied, and the Informer must be rebooted before the changes take effect.

Table 8 Input and Output Configuration

Product Family	Number of Inputs	Number of Outputs
IS-I-IP15	4	2
IS-I-IP100	4	2

WAV Files

Store over 4000 WAV files containing tones, music, or voice messages on a removable SD card in the Informers. The WAV files can be configured to play when a local input is activated. The Informer indoor and outdoor speakers include four digital inputs. These inputs can be configured to directly activate the speaker to play a string of 1-19 WAV files and control integrated relay output(s). The Informers are remotely configurable and can obtain software updates through the speaker's web page.

WAV File Control Commands

The Informer can store over 4000 WAV files containing tones, music, or voice messages on a removable SD card. The WAV files are stored in numerical order and can be commanded to play by the WAV file index number.

NOTE: There are over 160 standard messages included on the SD card. See “Appendix A Standard DV Messages” on page 50 for a complete list.

Invalid WAV File Control Commands

Examples of illegal WAV file Control Commands.

Table 9 Examples of Illegal WAV Files

Invalid WAV Files Control Commands	Why
*1	Missing end of frame character. The entry is discarded 5 seconds after 1 is received.
111*	Missing start of frame character before 111. The entry is discarded 5 seconds after * is received.
*1#	# is not a legal framing character for WAV file control and cannot be used in a command with a * framing character. The entry is discarded 5 seconds after # is received.
#1*1*	# is not a valid WAV file framing character. #1 is discarded, but *1* is accepted to activate WAV file number one.
#1#	#1# is a Function Control command that activates Function #1 and is not a WAV file command.
1A	A is not a legal digit. The entry is discarded 5 seconds after * is received.
5000	Valid WAV file index numbers are limited to 1-4093. The entry is discarded 5 seconds after * is received.

Function Control Commands

Function Control commands are used to activate functions that have been preconfigured into the Informer. Functions can be configured to control audio volume, activate relay outputs, play tones, and play WAV files. Functions configured with Commander® can also include delays and repeat loops.

The input functions can be configured on the Informer’s web page and activated by initiating local digital inputs on the Informer.

Configuring Informers Using the Web Interface

Informer products can operate as autonomous devices controlled by contact closures without connecting to a network server or becoming part of a supervised network with remote configuration, control, and status monitoring. Use the Informer’s internal web server to configure network settings, volume control, remote input configuration, access security, Modbus®, and SIP interfaces. More advanced configuration and programming require Federal Signal’s Commander software application and SmartMsg Centerpoint server. All configuration starts with the IP network interface.

1. Configuring the Network Interface

Before using an Informer on your network, a System Administrator must perform configurations. The System Administrator must be familiar with IP network equipment, this manual, and optionally the Commander Software Reference Manual. Proper configuration settings are required for the network to be able to reliably communicate with the device and create a redundant, fail-safe network architecture for your system.

You can statically address the Informer or configure it for DHCP. For permanent installations and good network management, it is recommended to reserve static IP addresses for all Informer devices on the network. The factory default setting places the Informer on a static IP address of 10.10.10.1 with a subnet mask of 255.255.0.0 on port 16887. If the configuration information is lost, restore the unit to this factory default setting with a hardware reset.

Reserve static (typically private) IP addresses on your network for each Federal Signal network server and for each Informer and any other Federal Signal network equipment such as sirens, SIU, or PA interface devices. If the Informers are used with the Commander[®] application, you must reserve a unique numeric site ID number for use by the Commander software to identify each Commander Control Station, Informer, and siren devices. Do not duplicate IP addresses or site ID numbers on the network at any time, or network errors occur. Informer and Siren Site ID numbers start at number 001 and are numbered sequentially. Commander Control Station Site ID numbers start at number 900.

Configuring the Network Interface through the Web Browser

If the configuration details are lost or changed incorrectly, restore the Informer to factory default settings. See “9. Restoring Configuration to Factory Defaults” on page 46.

Login

To configure the network interface through the web browser:

1. Before installing Informer devices on an IP network, connect your PC to the Informer device using a LAN cable. Turn on the Informer device.
2. Change your Local Area Connection (Ethernet) adapter address to the following:
IP Address: 10.10.10.10
Subnet Mask: 255.255.0.0
Default Gateway: 10.10.10.10
This will allow you to access the Informer at its default IP address (10.10.10.1).
3. Enter the default 10.10.10.1 IP address or the preconfigured static address for the Informer into your web browser to view the web page of the device.

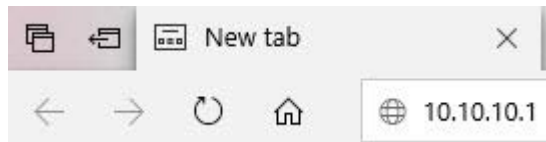

The Login window displays.

Windows Security

Microsoft Edge

The server 10.36.234.50 is asking for your user name and password.

That server also reports: "Federal Signal".

User name

Password

Remember my credentials

OK Cancel

4. Enter the Username:
admin (or preconfigured Username)
 5. Enter the Password:
fedsig (or preconfigured Password)
- NOTE:** The password is case sensitive.
6. Click OK.

The Home page displays.



Informer-IP Series C

[Home](#)
[Network](#)
[RTU Settings](#)
[Multicast Zones](#)
[Security](#)
[User Setup](#)
[Certificates](#)
[Upload Firmware](#)
[Reboot](#)
[Factory Defaults](#)
[Log_Out](#)

Home

Welcome to the management and configuration web interface.

You can use the navigation menus on the left to access additional pages.

Model: Informer-IP Series C
 RTU Number: 25
 Description: Informer-IP Series C

SmartMsg Server: Online 10.36.235.23
 SmartMsg Failover List: 10.36.235.7:16887;DESKTOP-TSDVITQ:16887;
 SIP Status: Offline

MAC Address: 00:40:9D:D4:D1:E0
 IPv4 Addresses: 10.36.235.36
 169.254.182.10

DIGI Firmware Version: 2.1.0.52
 RTU Firmware Version: 6.1.0.26

Up Time: 2 days 22 hours 18 minutes 12 seconds

The Home page displays a summary of the current configuration settings for the RTU. The Navigation Menu (blue hyperlinks on the left) is used to access other System Management web pages. Use the Help hyperlink to access the user manual from any web page.

NOTE: It may take up to 1 minute to update all the fields on the Home page after applying power or resetting the RTU. Click the Home menu to refresh and update the page.

Fields	Description
Model	The RTU model of the device. This field will be blank for a few minutes following power up or master reset.
RTU Number	The RTU's assigned identity.
Description	The RTU's description.
SmartMsg Server	The RTU's assigned default SmartMsg server.
SmartMsg Failover List	The RTU's SmartMsg Failover List. This field is blank until the unit successfully connects to the server and retrieves the failover list.
SIP Status	The RTU's SIP connection status. When the RTU is registered with a SIP server, the status will be Online, and the SIP server's IP address will be displayed. Offline will be displayed when the RTU is not registered with a SIP server.
MAC Address	The MAC Address of the device.
IPv4 Addresses	The RTU's assigned IPV4 address or its domain name.
DIGI Firmware Version	The firmware version of the DIGI Connect ME 9210 module.
RTU Firmware Version	The firmware version of the RTU.
Up Time	The elapsed time since power up or reboot.

- Record the MAC and IP address in Appendix B to ensure the device can be managed in the future.

Changing the Network Settings

You can configure the RTU to obtain an IP address automatically using DHCP and AutoIP, or you can assign a Static IP address. Coordinate the static IP addresses with the system Network Manager to prevent address duplication.

You cannot leave the Default Gateway blank when a static IP address is assigned. A valid IP address is required. Use the server's IP address as the gateway if making a direct Ethernet connection to the device.

After changes are made, click the Apply button and Reboot the RTU to begin using the new configuration settings. Reboot the RTU by cycling power or from the Reboot web page.

Use a MAC/IP address discovery tool to locate the IP address of the RTU if the network configuration settings are lost, misconfigured, or if DHCP is used. You must use the tool on the same side of a network router as the RTU. Contact Federal Signal Customer Support; see "Getting Service" on page 49 with the discovery tool.

To change the network settings:

1. Click Network. The Network Settings page displays.



Informer-IP Series C

- [Home](#)
- [Network](#)
- [RTU Settings](#)
- [Multicast Zones](#)
- [Security](#)
- [User Setup](#)
- [Certificates](#)
- [Upload Firmware](#)
- [Reboot](#)
- [Factory Defaults](#)
- [Log Out](#)

Network Settings

IP v4 Settings

Obtain an IP address automatically
 Use the following IP address

IP v4 Address:
 Subnet Mask:
 Default Gateway:
 Primary DNS:
 Secondary DNS:

MAC Address

MAC Address:

Fields	Description
Obtain an IP address automatically	When the device is rebooted, it obtains new network settings automatically from the network DHCP server.
Use the following IP address	Supplies static settings. You must enter an IP Address, Subnet Mask, and Gateway. A DNS server address is required only if domain names are used instead of IP addresses.
IP Address or Domain Name	The RTU's assigned IPV4 address or its domain name in the IP address field.
Subnet Mask	The RTU's assigned subnet mask.
Default Gateway	The RTU's network gateway for routing IP traffic.
Primary DNS	The Primary Domain Name Server for the network. (Must be entered if the RTU is required to connect to a server by its domain name.)
Secondary DNS	The Secondary Domain Name Server for the network.
Apply	Saves your settings. You must reboot for changes to take effect.

2. Select the Use the following IP address option button.
3. Enter the static IP Address, Subnet Mask, and Default Gateway for the Informer device.
4. Click Apply.

5. Reboot the device for the IP address change to take effect.

NOTE: If the Informer will be used autonomously without residing on an IP network, use the default settings network to configure the Informer. If the Informer is connected to a network, the factory default IP settings must be changed to work with the IP network that the product will be connected to. Consult with your Network Manager to ensure that the settings adhere to your network policy.

Once the IP address is changed, configuration is possible only when the Informer and the configuration computer are placed on the same network together. Reconfigure the configuration computer's IP settings before returning to the same network. You must log in to the web page with the new IP address after the address is changed.

NOTE: You can use DHCP to simplify Informer deployment, but MAC address discovery tools may not traverse routers, and maintenance may be more difficult.

2. Configuring the RTU Settings

When the RTU is used with Commander®, the device's RTU Number and Description must be entered, and SmartMsg must be enabled. All devices in the system must have a unique RTU Number, and it should start with 001. If Commander is not going to be used, SmartMsg should not be enabled, and a unique RTU number does not need to be entered.

NOTE: The number of relay outputs differs between Informer models, and configuration examples are not shown for every model.

Digital Inputs

You can assign Digital Inputs to play digital voice messages when the input becomes active. Inputs that have been programmed from Commander for local activation cannot be configured from the webpage and will be unavailable.

After changes are made, click the Apply button and then reboot the RTU from the Reboot web page to begin using the new configuration settings. See the following screen captures to configure the RTU Settings of the Informer.

To change the configure the RTU Settings of the Informer:

1. Click RTU Settings.

The RTU Settings page displays.



Informer-IP15 Series C

[Home](#)
[Network](#)
[RTU Settings](#)
[Multicast Zones](#)
[Security](#)
[User Setup](#)
[Certificates](#)
[Upload Firmware](#)
[Reboot](#)
[Factory Defaults](#)
[Log Out](#)

RTU Settings

General

RTU Number:

Description:

Power Attenuation:

Ambient Attenuation:

SmartMsg

Enable SmartMsg

SmartMsg Server:

SmartMsg Port:

Modbus

Enable Modbus

Modbus Port:

SIP

Enable SIP (*Setting also applies to Multicast)

SIP Port:

SIP TLS Port:

Local Address:

Primary SIP Server:

Secondary SIP Server:

Address (Extension):

Registration User ID:

Password:

Registration Interval:

Call Time Limit:

*Underrun (Jitter) Delay:

Transport:

Private Key Passphrase:

SSL Common Name:

Keepalive Mode:

Keepalive Interval:

*QoS:

*Relay 1:

*Relay 2:

*Pretone:

Digital Inputs

Input #1:

Mode: ▾
Polarity: ▾
Priority: ▾
Digital Voice:
Relay 1:
Relay 2:

Input #2:

Mode: ▾
Polarity: ▾
Priority: ▾
Digital Voice:
Relay 1:
Relay 2:

Input #3:

Mode: ▾
Polarity: ▾
Priority: ▾
Digital Voice:
Relay 1:
Relay 2:

Input #4:

Mode: ▾
Polarity: ▾
Priority: ▾
Digital Voice:
Relay 1:
Relay 2:

Fields	Description
General	
RTU Number	The RTU's assigned identity. All devices in the system must have a unique RTU Number. The number must be a positive integer.
Description	Use this 48-character text field to describe the RTU. This can be the physical address of the site or any other text string. The description field has a 255-character limit and can be scrolled to view additional characters.
Power Attenuation	Use to set the default volume level. The selected level applies to SIP audio and all other functions unless overridden by Commander®. The selected value defines dB attenuation from full volume: 0 dB is full volume, and 20 dB is minimum volume.

Fields	Description
Ambient Attenuation	Use to set the default Ambient Attenuation Threshold. The selected level applies to SIP audio and all other functions unless overridden by Commander®. The sound level will start attenuating when the ambient SPL drops below this threshold.
SmartMsg	
Enable SmartMsg	Check to enable the SmartMsg interface.
SmartMsg Server	The RTU's assigned default SmartMsg Server IP Address or DNS name.
SmartMsg Port	The port is preconfigured to 16887.
Modbus	
Enable Modbus	Check to enable the Modbus® interface.
Modbus Port	The RTU's assigned Modbus TCP port number. The default is 502.
SIP	
Enable SIP	Check to enable the SIP interface
SIP Port	The RTU's assigned SIP port number. The default is 5060.
SIP TLS Port	The RTU's assigned TLS SIP port number. The default is 5061
Local Address	Displays the RTU's IP address.
Primary SIP Server	The RTU's assigned primary SIP server.
Secondary SIP Server	The RTU's assigned secondary SIP server. If your system does not use a failover server, leave this field blank.
Address (Extension)	The RTU's assigned Address or Extension number. This field is required.
Registration User ID	Username for registration. If this field is blank, the Address (Extension) will be used for the Registration User ID.
Password	The RTU's assigned SIP password.
Registration Interval	The RTU's assigned SIP registration interval in seconds. Enter a value between 10 and 3600.
Call Time Limit	The RTU's assigned SIP call limit duration in seconds. The call is dropped automatically when the time limit is reached. This prevents a speaker from staying busy if a phone is left off the hook or on hold unintentionally. Enter a value between 10 and 3600.
Underrun (Jitter) Delay	Underrun occurs when a device runs out of data during live streaming PA or VoIP, causing the audio to cut out. The underrun delay setting defines the length of data buffering to use before playback begins. The buffer size is adjustable from 0–15 seconds. The buffer duration can be set to 0 on high-speed networks designed for VoIP traffic. Wireless networks and networks without QoS may require additional buffering to eliminate jitter and lost audio.
Transport	The RTU's assigned SIP transport protocol. For TLS, optional certificates can be uploaded from the Certificates page.

Fields	Description
Private Key Passphrase	The RTU's assigned private key passphrase. Leave this field blank if a private key certificate is not provided or does not require a passphrase.
SSL Common Name	The Common Name associated with the SIP Server's SSL certificate. This field must be left blank if a CA certificate is not provided or if it is desired to not validate the server certificate.
Keepalive Mode	If enabled, the RTU will send a keepalive message to the server at the specified interval.
Keepalive Interval	The keepalive interval in seconds. Enter a value between 10 and 3600.
QoS	The differentiated services code point value assigned to signaling messages from the RTU.
Relay 1	Turns on Relay 1 during a SIP call.
Relay 2	Turns on Relay 2 during a SIP call.
Pretone	<p>The Pretone feature allows a prerecorded digital voice message to be played at the start of an incoming SIP or Multicast session before live audio begins. Typically, this is used to gain attention before speaking. While the Pretone is playing, up to 30 seconds of public address audio will be buffered and play out after the Pretone message. It is good practice to limit the duration of Pretone messages to 3-5 seconds. To enable Pretone, select a digital voice message from the dropdown list. To disable, select None (default setting).</p> <p>When making an announcement with the Pretone feature, users should make a call, wait approximately one second for the call to be established, make the announcement, and then hang up. The Pretone will play followed by the announcement.</p>
Digital Inputs	
Mode	<p>The digital input mode. Available options:</p> <ul style="list-style-type: none"> • Disabled: The digital input is not configured for local activation. • Commander[®]: The digital input is configured for local activation from Commander. This selection is for display only, and if selected the mode will revert to Disabled. • Momentary: The selected digital voice message(s) will play one time when the state changes from Inactive to Active. • Continuous: The selected digital voice message(s) will play continuously while the input is Active. <p>If more than one input is configured for Continuous mode, the WAV file(s) and relay output(s) associated with each input will activate in sequence as long as the inputs are active.</p>
Polarity	<p>The polarity of the digital input active state.</p> <p>Normally Open: Active state is input Closed.</p> <p>Normally Closed: Active state is input Open.</p>

Fields	Description
Priority	The Priority assigned to the digital input. For Momentary mode, an input of equal or higher priority interrupts an active Continuous mode input and stops and overrides currently active Momentary mode input. When multiple Continuous mode inputs are active with different priorities, the lower priority inputs are skipped until the higher priority inputs become inactive. The highest priority is 1, and the lowest is 4.
Digital Voice	List of digital voice messages to play when the input becomes active. This field must be a comma-delimited list of 1–19 digital voices indices (for example, 1,2,3,4).
Relay 1	Turns on Relay 1 when the input is active.
Relay 2	Turns on Relay 2 when the input is active. The relays will remain on while the DV messages are playing in Momentary mode. The relays will remain on as long as the input is active in Continuous mode.
Apply	Saves your settings. You must reboot for changes to take effect.

2. Enter the RTU Number.
3. Enter a description of the RTU.
4. In the Power Attenuation box, type or select a the default volume level.
5. In the Ambient Attenuation box, type or select the ambient attenuation threshold.
6. Click Enable SmartMsg to enable the SmartMsg interface.
7. Click Enable Modbus to enable the Modbus® interface.
8. Click Enable SIP to enable SIP.
9. Enter the fields for the Digital Inputs #1 through #4 to assign that Digital Input to play digital voice messages. Inputs that have been programmed from Commander® for local activation cannot be configured from the webpage and will be unavailable.
10. Click Apply.
11. Reboot the device for the IP address change to take effect.

3. Configuring the Multicast Zones

The Multicast Transmit Zone (siren audio) streams siren audio to a multicast IP Address. To configure it, enter a valid multicast IP Address and Port Number, and check the Enable box.

The Multicast Transmit Zone (microphone audio) streams microphone audio to the multicast IP address when the speaker is not receiving a page, playing a WAV file or a tone. This feature allows phones and other VoIP devices to listen to the background audio.

The Informer100 will receive audio from up to 50 multicast receive zones (Rx Zones). To configure a zone to receive public address messages, enter a valid multicast IP Address, Port Number, and check the Enable box for the zone.

NOTE: Multicast Transmit Zone (microphone audio) is only available in Informer15 and Informer100 speakers.

To configure a multicast zone to receive public address messages:

1. Click Multicast Zones.

The Multicast Zones page displays.



Informer-IP15 Series C

- [Home](#)
- [Network](#)
- [RTU Settings](#)
- [Multicast Zones](#)
- [Security](#)
- [User Setup](#)
- [Certificates](#)
- [Upload Firmware](#)
- [Reboot](#)
- [Factory Defaults](#)
- [Log Out](#)

Multicast Zones

Priority Settings

Lower numbered zones preempt higher numbered zones.

Individual calls preempt multicast zones.

Multicast Transmit Zone (siren audio)

Tx Zone	IP Address	Port	Enabled
Zone 1	<input type="text" value="239.20.19.115"/>	<input type="text" value="8228"/>	<input checked="" type="checkbox"/>

Multicast Transmit Zone (microphone audio)

Tx Zone	IP Address	Port	Enabled
Zone 1	<input type="text" value="239.20.19.116"/>	<input type="text" value="8229"/>	<input type="checkbox"/>

Multicast Receive Zones

Rx Zone	IP Address	Port	Enabled
Zone 1	<input type="text" value="239.20.19.117"/>	<input type="text" value="8228"/>	<input type="checkbox"/>
Zone 2	<input type="text"/>	<input type="text" value="0"/>	<input type="checkbox"/>
Zone 3	<input type="text"/>	<input type="text" value="0"/>	<input type="checkbox"/>
Zone 4	<input type="text"/>	<input type="text" value="0"/>	<input type="checkbox"/>
Zone 5	<input type="text"/>	<input type="text" value="0"/>	<input type="checkbox"/>
Zone 6	<input type="text"/>	<input type="text" value="0"/>	<input type="checkbox"/>
Zone 7	<input type="text"/>	<input type="text" value="0"/>	<input type="checkbox"/>
Zone 8	<input type="text"/>	<input type="text" value="0"/>	<input type="checkbox"/>
Zone 9	<input type="text"/>	<input type="text" value="0"/>	<input type="checkbox"/>
Zone 10	<input type="text"/>	<input type="text" value="0"/>	<input type="checkbox"/>
Zone 11	<input type="text"/>	<input type="text" value="0"/>	<input type="checkbox"/>
Zone 12	<input type="text"/>	<input type="text" value="0"/>	<input type="checkbox"/>
Zone 13	<input type="text"/>	<input type="text" value="0"/>	<input type="checkbox"/>
Zone 14	<input type="text"/>	<input type="text" value="0"/>	<input type="checkbox"/>
Zone 15	<input type="text"/>	<input type="text" value="0"/>	<input type="checkbox"/>
Zone 16	<input type="text"/>	<input type="text" value="0"/>	<input type="checkbox"/>
Zone 17	<input type="text"/>	<input type="text" value="0"/>	<input type="checkbox"/>

Zone 18	<input type="text"/>	<input type="text" value="0"/>	<input type="checkbox"/>
Zone 19	<input type="text"/>	<input type="text" value="0"/>	<input type="checkbox"/>
Zone 20	<input type="text"/>	<input type="text" value="0"/>	<input type="checkbox"/>
Zone 21	<input type="text"/>	<input type="text" value="0"/>	<input type="checkbox"/>
Zone 22	<input type="text"/>	<input type="text" value="0"/>	<input type="checkbox"/>
Zone 23	<input type="text"/>	<input type="text" value="0"/>	<input type="checkbox"/>
Zone 24	<input type="text"/>	<input type="text" value="0"/>	<input type="checkbox"/>
Zone 25	<input type="text"/>	<input type="text" value="0"/>	<input type="checkbox"/>
Zone 26	<input type="text"/>	<input type="text" value="0"/>	<input type="checkbox"/>
Zone 27	<input type="text"/>	<input type="text" value="0"/>	<input type="checkbox"/>
Zone 28	<input type="text"/>	<input type="text" value="0"/>	<input type="checkbox"/>
Zone 29	<input type="text"/>	<input type="text" value="0"/>	<input type="checkbox"/>
Zone 30	<input type="text"/>	<input type="text" value="0"/>	<input type="checkbox"/>
Zone 31	<input type="text"/>	<input type="text" value="0"/>	<input type="checkbox"/>
Zone 32	<input type="text"/>	<input type="text" value="0"/>	<input type="checkbox"/>
Zone 33	<input type="text"/>	<input type="text" value="0"/>	<input type="checkbox"/>
Zone 34	<input type="text"/>	<input type="text" value="0"/>	<input type="checkbox"/>
Zone 35	<input type="text"/>	<input type="text" value="0"/>	<input type="checkbox"/>
Zone 36	<input type="text"/>	<input type="text" value="0"/>	<input type="checkbox"/>
Zone 37	<input type="text"/>	<input type="text" value="0"/>	<input type="checkbox"/>
Zone 38	<input type="text"/>	<input type="text" value="0"/>	<input type="checkbox"/>
Zone 39	<input type="text"/>	<input type="text" value="0"/>	<input type="checkbox"/>
Zone 40	<input type="text"/>	<input type="text" value="0"/>	<input type="checkbox"/>
Zone 41	<input type="text"/>	<input type="text" value="0"/>	<input type="checkbox"/>
Zone 42	<input type="text"/>	<input type="text" value="0"/>	<input type="checkbox"/>
Zone 43	<input type="text"/>	<input type="text" value="0"/>	<input type="checkbox"/>
Zone 44	<input type="text"/>	<input type="text" value="0"/>	<input type="checkbox"/>
Zone 45	<input type="text"/>	<input type="text" value="0"/>	<input type="checkbox"/>
Zone 46	<input type="text"/>	<input type="text" value="0"/>	<input type="checkbox"/>
Zone 47	<input type="text"/>	<input type="text" value="0"/>	<input type="checkbox"/>
Zone 48	<input type="text"/>	<input type="text" value="0"/>	<input type="checkbox"/>
Zone 49	<input type="text"/>	<input type="text" value="0"/>	<input type="checkbox"/>
Zone 50	<input type="text"/>	<input type="text" value="0"/>	<input type="checkbox"/>

Fields	Description
Priority Settings	
Lower numbered zones preempt higher numbered zones	Allows pages in a lower numbered zone to interrupt a higher numbered zone.
Individual calls preempt multicast zones	Allows individual calls to interrupt multicast pages.
Multicast Transmit Zone (siren audio)	All audio sources except incoming Multicast Receive Zones are routed to the Multicast TX Zone. Configure only one RTU per Zone with a Multicast TX Zone to prevent Multicast audio contention. Do not allow other devices to multicast to the same address and port (Multicast Zone) at the same time the Informer-IP is multicasting.
IP Address	Multicast IP address between 234.0.0.0 and 239.255.255.255.
Port	Port number between 1 and 65535.
Enabled	Check to send activation audio to this zone.

Fields	Description
Multicast Transmit Zone (microphone audio)	The Multicast Transmit Zone (microphone audio) streams microphone audio to the multicast IP address when the speaker is not receiving a page, playing a WAV file, or playing a tone. This feature allows phones and other VoIP devices to listen to the background audio.
IP Address	Multicast IP address between 234.0.0.0 and 239.255.255.255.
Port	Port number between 1 and 65535.
Enabled	Check to send activation audio to this zone.
Multicast Receive Zones	If Zone priority is not configured or if two zones are configured with the same priority, the RTU listens to audio only from the first source that started multicasting until the RTU detects the original source has stopped sending RTP audio. This prevents audio contention if two sources attempt to multicast to the same address and port at the same time. If Zone priority is enabled, audio from the highest priority zone overrides all other multicast zone traffic.
IP Address	Multicast IP address between 234.0.0.0 and 239.255.255.255.
Port	Port number between 1024 and 65535.
Enabled	Check to subscribe to this zone.
Apply	Saves your settings. You must reboot for changes to take effect.

2. Enter a valid multicast IP Address and Port Number, and check the Enabled box for the zone.
3. Click Apply.
4. Reboot the device for the IP address change to take effect.

4. Configuring Security

Configure up to four IP address filters to limit access to incoming SIP calls. If one or more filters are enabled, the source IP address of the caller must be within one of the enabled filter ranges, or the call is rejected. When using a SIP server, the source IP address is the SIP server or proxy server.

NOTE: The IP Address Filter does not apply to Multicast paging.

To configure security:

1. Click Security.

The Security page displays.

Informer-IP Series C

[Home](#)
[Network](#)
[RTU Settings](#)
[Multicast Zones](#)
[Security](#)
[User Setup](#)
[Certificates](#)
[Upload Firmware](#)
[Reboot](#)
[Factory Defaults](#)
[Log Out](#)

Security			
SIP IP Filter			
IP Filter	Start IP Address	End IP Address	Enabled
1	<input type="text"/>	<input type="text"/>	<input type="checkbox"/>
2	<input type="text"/>	<input type="text"/>	<input type="checkbox"/>
3	<input type="text"/>	<input type="text"/>	<input type="checkbox"/>
4	<input type="text"/>	<input type="text"/>	<input type="checkbox"/>

Field	Description
SIP IP Filter	
Start IP Address	Starting IP Address in dotted-decimal format.
End IP Address	Ending IP Address in dotted-decimal format. The ending IP address must be a greater value than the starting IP address.
Enabled	Check the box to enable this filter. If all filters are disabled, the system will accept any IP address. If one or more filters are enabled, the source IP address must be within one of the enabled filter ranges.
Apply	Saves your settings. You must reboot for changes to take effect.

2. Enter the starting IP Address in dotted-decimal format.
3. Enter the ending IP Address in dotted-decimal format.
4. Click Enabled.
5. Click Apply.
6. Reboot the device for the IP address change to take effect.

5. Configuring the User Setup

User Setup allows Full Admin privileged users to create users, create passwords, and assign security privileges.

You cannot delete the Admin user or change the security privilege for the Admin user. You can change the Admin user's username and password.

To create users and enable the factory support user:

1. Click User Setup.

The User Setup page displays.



Informer-IP Series C

- [Home](#)
- [Network](#)
- [RTU Settings](#)
- [Multicast Zones](#)
- [Security](#)
- [User Setup](#)
- [Certificates](#)
- [Upload Firmware](#)
- [Reboot](#)
- [Factory Defaults](#)
- [Log Out](#)

User Setup

Admin

Username:

Password:

Password Confirm:

Privileges:

User 1

Username:

Password:

Password Confirm:

Privileges:

User 2

Username:

Password:

Password Confirm:

Privileges:

User 3

Username:

Password:

Password Confirm:

Privileges:

User 4

Username:

Password:

Password Confirm:

Privileges:

Factory Support User

Enable Factory Support User

Fields	Description
Username	Enter the name of the user (case sensitive).
Password	Enter the user's password (case sensitive).
Password Confirm	Enter the user's password again. The Password Confirm must match the Password.
Privileges	In the Privilege list, select one of the following: <ul style="list-style-type: none"> Full Admin: Has unrestricted access to all configuration screens View and Configuration: Can configure all settings except User Setup View Only: Can only view the Home screen
Enable Factory Support User	Check to enable the factory support user. When enabled, a hidden static user and password is enabled for Federal Signal technical support. You can disable this user.
Apply	Saves your settings. You must reboot for changes to take effect.

- For the Admin fields, enter the default Username:
admin (This is the default username.)
- For the Admin fields, enter the Password:
fedsig (This is the default password.)
NOTE: The password is case sensitive.
- Enter the fields for Users 1 through 4 to create optional users. Each username requires a password and a security privilege.
- Click Enable Factory Support User to enable a hidden static user and password for Federal Signal Technical Support.
- Click Apply to save changes.
- Reboot the device to load the changes into the RTU

6. Uploading Certificates

Use the Certificates page to upload certificate files to support secure SIP TLS communication. Certificate files are optional, and if provided, allow for CA certificate validation.

File type	Filename
CA certificate	ca-cert.pem
Device SSL certificate	cert.pem
Device private key	key.pem

To upload a certificate file:

1. Click Certificates.

The Certificates page displays.

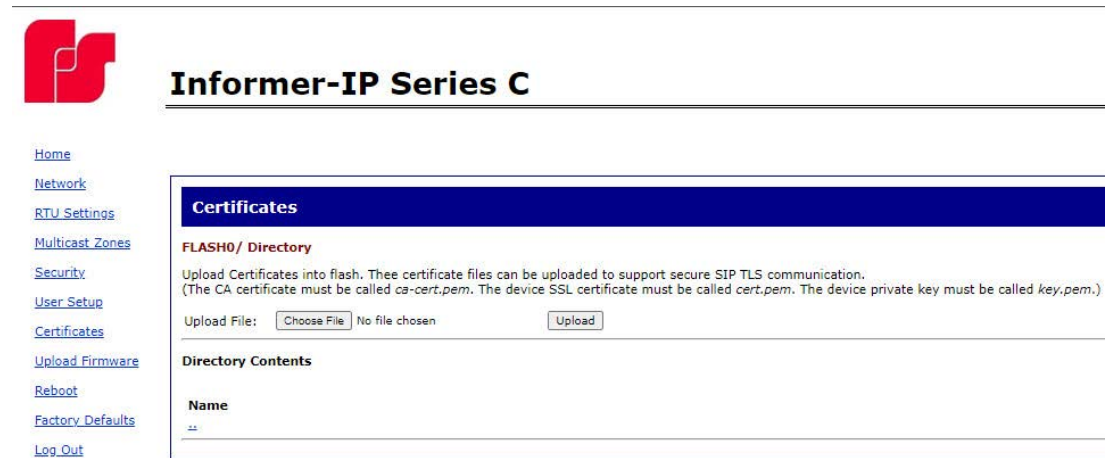

Fields	Description
Choose File	Choose the new ca-cert.pem, cert.pem or key.pem file.
Upload	Upload the new file.

2. Click Browse to select the new ca-cert.pem, cert.pem, or key.pem file.
3. Click Upload to upload the new file.
4. Reboot the device for the changes to take effect.

7. Uploading Firmware

Use the Upload Firmware page to load a new operating system into the Digi® Ethernet module. The Home page displays the current version of the firmware.

To upload new firmware:

1. Click Upload Firmware.

The Upload Firmware page displays.

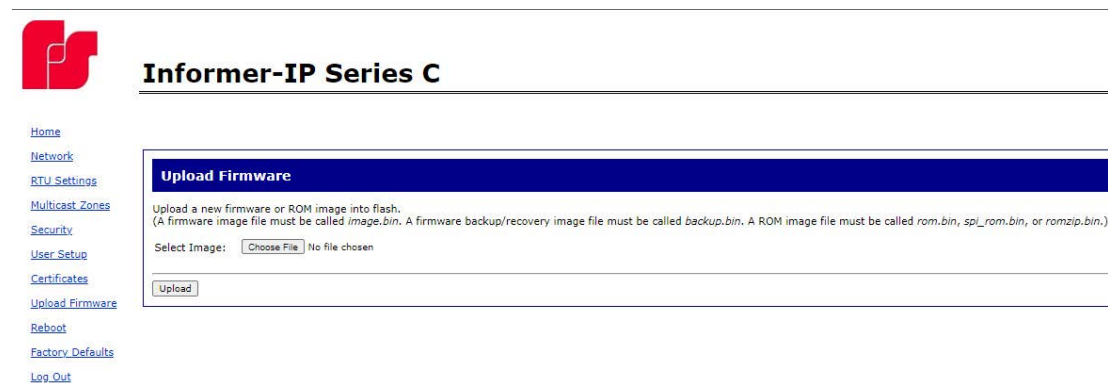

Fields	Description
Choose File	Click Choose File to open a dialog box. Select the new image.bin file to upload.
Upload	Click the Upload button to upload the new image.bin file.

- Click Browse to open a dialog box to select the new image.bin file to upload.

File type	Filename
Firmware image file	image.bin
Firmware backup or recovery image	backup.bin
ROM image	rom.bin, spi_rom.bin, or romzip.bin

- Click the Upload button to upload the new image.bin file.

IMPORTANT: To prevent operating system corruption, power must not be interrupted during the upload process.

- Reboot the device for the changes to take effect.

8. Rebooting Device and Loading Configuration Settings

Use the Reboot page to reboot the device and load new configuration settings.

To reboot the device and load new configuration settings:

- Click Reboot.

The Reboot page displays.



- Click the Reboot button to reboot the device and load new configuration settings.

The login prompt displays within 20 seconds after the reboot.

9. Restoring Configuration to Factory Defaults

You can restore the factory default settings with or without restoring the network parameters.

Default Settings

RTU Number: 1
 Description: my description
 SmartMsg disabled
 Modbus disabled
 Smartmsg Server: 10.10.10.10
 IP Address: 10.10.10.1
 Subnet Mask: 255.255.0.0
 Default Gateway: 10.10.10.10
 Primary/Secondary DNS: 0.0.0.0/0.0.0.0
 Admin user name: admin
 Admin user password: fedsig
 User 1 - User 4 username/password: blank
 Factory Support User: Enabled

To restore configuration to factory defaults:

1. Click Factory Defaults.

The Factory Defaults page displays.



Informer-IP Series C

- [Home](#)
- [Network](#)
- [RTU Settings](#)
- [Multicast Zones](#)
- [Security](#)
- [User Setup](#)
- [Certificates](#)
- [Upload Firmware](#)
- [Reboot](#)
- [Factory Defaults](#)
- [Log Out](#)

Factory Defaults

Restore Factory Defaults

Include Network Parameters

Press Apply button to restore factory defaults. **Warning! The device settings will be overwritten.**

Fields	Description
Include Network Parameters	Check to include network parameters. IMPORTANT: This changes the IP address of the RTU to factory default settings and makes the device inaccessible over a production network.
Apply	Restores your settings to the factory defaults. IMPORTANT: Your current settings will be overwritten.

2. Click Apply to restore your settings to the factory defaults.
3. Reboot the device for the changes to take effect.

If the configuration details are lost or changed incorrectly and it becomes necessary to restore the Informer to factory default settings, perform a Power-On Factory Default procedure.

Restoring the Informer-IP to Factory Default

The Informer-IP can be restored to the factory default by either using the web pages or the RESET button.

Using the Web Pages

To restore the configuration to the factory default by using the web pages:

1. Navigate to the IP address of the Informer using a web browser and log in.
2. Select Factory Default. Include or Exclude Network Settings.
3. Click Apply to restore your settings to the factory defaults.
4. Reboot the device for the changes to take effect.

Using the RESET Button

To restore the configuration to the factory default by using the RESET button:

1. Remove power from the Informer.
2. Press and hold down the RESET button.
3. Apply power while holding down the RESET button until the Power and Test LEDs begin to blink, confirming that the default configuration has been loaded.

You must reenter all local configuration settings before placing the Informer into service.

Restoring the Informer100 and IS-I-IP15 to Factory Default

The Informer100 and IS-I-IP15 can be restored to the factory default by either using the web pages or Factory Default Jumper.

Using the Web Pages

To restore the configuration to the factory default by using the web pages:

1. Navigate to the IP address of the Informer using a web browser and log in.
2. Select Factory Default. Include or Exclude Network Settings.
3. Click Apply to restore your settings to the factory defaults.
4. Reboot the device for the changes to take effect.

Using Factory Default Jumper

To restore the configuration to the factory default using the factory default jumper:

1. Apply power to the Informer for at least 60 seconds to allow it to boot.
2. Short JP11 on the control board for 10 seconds, and then remove the short.
3. Wait 60 seconds for the Informer to reboot with the factory default settings.

You must reenter all local configuration settings before placing the Informer into service.

10. Logging Out of the Web Interface

Use the Log Out page to log out before the five-minute session timer expires.

To log out of the web interface:

1. Click Log Out.

The Log Out page displays.



2. Click the Log Out button to log out.

Ordering Replacement Parts

To order replacement parts, call Customer Care. See Getting Service.

Table 10 Replacement Parts

Description	Part Number
Service Kit, 20000314-01 PCBA Includes: IP Control PCB Only	Q-20000314-01
Service Kit, IP100, AC Model Includes: Assembled front housing, driver, power supply, and amplifier	Q-IP100AC
Service Kit, IP100, DC Model Includes: Assembled front housing, driver, and amplifier	Q-IP100DC
Service Part Fuse 2 per AC unit Bussman part – GDC-3.15A Littlefuse part p 2183.15HXP	K148186A-01
Service Part 1 per Amplifier Littlefuse part 0297010.wxnv	Not Available through Federal Signal

Getting Service

If you are experiencing any difficulties, contact Federal Signal Customer Support at 1-800-344-4634 or 1-708-534-4756 or Technical Support at 1-800-755-7621 or 1-708-587-3587 or through e-mail at signalsupport@fedsig.com. For instruction manuals and information on related products, visit <http://www.fedsig.com>.

Appendix A Standard DV Messages

Table 11 Standard DV Messages

#	FWS Name	Customer Name for DV	Description	Notes
1	FWS-13955	TM1	(5 sec) Wail-Conventional Siren 560-1055 Hz	
2*	FWS-13956	TM2	(5 sec) Yelp-Rapid Siren 560-1055 Hz	
3*	FWS-13957	TM3	(5 sec) High-Low-Alternating High and Low 561 Hz and 760 Hz	
4	FWS-13958	TM4	(5 sec) Bell-Bell, Struck Rapidly-801 Hz	
5	FWS-13959	TM5	(5 sec) Yeow-Descending High to Low, Repeated 545 Hz and 1296 Hz	
6	FWS-13960	TM6	(5 sec) Horn-Steady Horn	470 Hz
7	FWS-13961	TM7	(5 sec) Beep-Slow Intermittent Horn 470 Hz	
8	FWS-13962	TM8	(5 sec) Stutter-Rapid Intermittent Horn 470 Hz	
9	FWS-13963	TM9	(5 sec) Slow Whoop-Slow Ascending Low to High, Repeated 424 Hz and 1163 Hz	
10	FWS-13964	TM10	(5 sec) Gradual Horn-Steady Horn, Gradually Increasing in Volume 514 Hz	
11	FWS-13965	TM11	(5 sec) Temporal Slow Whoop-NFPA Coded Slow Whoop 424 Hz and 774 Hz	
12	FWS-13966	TM12	(9 sec) Westminster Chime-Westminster Chime-Musical Tone	
13	FWS-13967	TM13	(5 sec) Evac-Amplitude Modulated Siren 479 Hz	
14	FWS-13968	TM14	(5 sec) Air Horn-Steady Horn 400 Hz and 800 Hz	
15	FWS-13969	TM15	(5 sec) Chime-Single Strike Chime-Musical Tone	
16	FWS-13970	TM16	(5 sec) Phaser-Rapid Siren	600-1200 Hz
17	FWS-13971	TM17	(5 sec) Alternating High and Low 363 Hz and 518 Hz	
18	FWS-13972	TM18	(5 sec) Warble-Extremely Rapid Siren 560-1055 Hz	
19	FWS-13973	TM19	(5 sec) Alert-Slow Sweep Tone 400-1560 Hz	
20	FWS-13974	TM20	(5 sec) Euro-Police-Alternating High and Low 969 Hz and 800 Hz	
21	FWS-13975	TM21	(5 sec) Euro-Fire Sweep Tone 900-800 Hz	
22	FWS-13976	TM22	(5 sec) Euro-Slow Whoop-Slow Sweep Tone 650-1290 Hz	
23.	FWS-13977	TM23	(5 sec) Euro-General-Intermittent Horn 969 Hz	
24*	FWS-13978	TM24	(5 sec) Euro-Toxic-Steady Horn 969 Hz	
25	FWS-13979	TM25	(5 sec) Euro-Police II-Slow Alternating High and Low 554 Hz and 440 Hz	
26	FWS-13980	TM26	(5 sec) Euro-Stutter-Intermittent Beep 2840 Hz	
27	FWS-13981	TM27	(5 sec) Euro-Sweep-Sweep Tone 1163-397 Hz	

#	FWS Name	Customer Name for DV	Description	Notes
28	FWS-13982	TM28	(5 sec) Ringer-Continuous Ringing Tone 560 Hz and 326 Hz	
29	FWS-13983	TM29	(5 sec) Buzzer-Buzzer Tone 1318 Hz and 760 Hz	
30	FWS-13984	TM30	(5 sec) Attention-Extremely Rapid Siren-Multiple Frequency	
31	FWS-13985	TM31	(5 sec) Multi-Tone-Extremely Rapid Siren-Multiple Frequency	
32	FWS-13986	TM32	(5 sec) Caution-Extremely Rapid Siren-Multiple Frequency	
33	FWS-13987	Three 1 kHz tones Pre-Announcement	Three 1 kHz tones Pre-Announcement	
34	FWS-13988	Wobulator-3 times Pre-Announcement	Wobulator-3 times Pre-Announcement	
35	FWS-13989	FWS-10274-DSP2 M1 - Chime - Pre-Announcement	DSP2 M1 - Chime - Pre-Announcement	
36	FWS-13990	3 blasts-5 sec- Pre-Announcement	3 blasts-5 sec- Pre-Announcement	
37	FWS-13991	TM4-3 times Pre-Announcement	TM4-3 times Pre-Announcement	
38	FWS-13992	M15-3 times Pre-Announcement	M15-3 times Pre-Announcement	
39	FWS-13993	52 horn 5 sec	52 horn 5 sec	
40	FWS-13994	52 horn 10 sec	52 horn 10 sec	
41	FWS-13995	52 horn 15 sec	52 horn 15 sec	
42	FWS-13996	52 horn 1 sec pulses 10 times	52 horn 1 sec pulses 10 times	
43	FWS-13997	1 kHz_30 sec	1 kHz_30 sec	
44	FWS-13998	(5 sec) Alt Steady	(5 sec) Alt Steady	
45	FWS-13999	(5 sec) Alt Wail	(5 sec) Alt Wail	
46	FWS-14000	(5 sec) Pulsed Steady	(5 sec) Pulsed Steady	
47	FWS-14001	(5 sec) Pulsed Wail	(5 sec) Pulsed Wail	
48	FWS-14002	(5 sec) Steady	(5 sec) Steady	
49	FWS-14003	(5 sec) Wail	(5 sec) Wail	
50	FWS-14004	Westminster Chime	Westminster Chime	
51	FWS-14005	Attention	Attention	
Severe Weather				
52	FWS-14006	Severe Weather Warning-Seek Shelter	"The National Weather Service has issued a severe weather warning. Take shelter immediately. Repeat, the National Weather Service has issued a severe weather warning. Take shelter immediately."	

Appendix A Standard DV Messages

#	FWS Name	Customer Name for DV	Description	Notes
53	FWS-14007	Severe Weather Warning-Seek Shelter	"This is a severe weather warning. Take shelter immediately. Repeat, severe weather warning. Take shelter immediately."	
54	FWS-14008	Severe Weather Alert-Seek Shelter	"Please take shelter immediately. This is a severe weather alert."	
55	FWS-14009	Severe weather Approaching-Seek Shelter	"Attention. Attention. This is an emergency. Severe weather approaching. Seek shelter immediately."	
56	FWS-14010	Severe Weather-Stay away from Windows	"Attention. A severe weather warning has been issued; proceed immediately to the interior of the building, away from windows and entrances."	
Tornado				
57	FWS-14011	Tornado Warning-Seek Shelter	"This is a tornado warning. Seek shelter immediately. This is a tornado warning. Seek shelter immediately."	
58	FWS-14012	Tornado Sighted-Seek Shelter	"Attention! Life-threatening situation. A tornado has been sighted in the area. Seek shelter inside or take cover immediately. Stay away from windows and doors."	
59	FWS-14013	Tornado Sighted-Seek Shelter	"Attention, a tornado has been sighted in the area. Take shelter immediately. Repeat, a tornado has been sighted in the area, take shelter immediately."	
60	FWS-14014	Tornado Warning-Seek Shelter	"This is a tornado warning. Seek shelter immediately. This is a tornado warning. Seek shelter immediately."	
61	FWS-14015	Tornado Warning-Designated Area	"Tornado Alert, report to your designated area."	
62	FWS-14016	Tornado Warning-Seek Shelter	"Attention! Attention! Tornado warning. Seek shelter immediately. Attention! Attention! Tornado warning. Seek shelter immediately."	
High Winds				
63	FWS-14017	High Wind	"Attention: The National Weather Service has issued a high wind warning. High winds are approaching. Take shelter immediately. Repeat, the National Weather Service has issued a high wind warning. High winds are approaching. Take shelter immediately."	
Flood/Water/Tsunami				
64	FWS-14018	River Level Warning	"Danger. River level rising."	
65	FWS-14019	Flood Warning	"Attention: A Flood Warning has been issued for this area. Tune to your local radio station for details."	
66	FWS-14020	Tsunami Warning	"Attention: A Tsunami Warning has been issued for this area. Tune to your local radio station for details."	

#	FWS Name	Customer Name for DV	Description	Notes
Lightning				
67	FWS-14021	Lightning-Take shelter	"Dangerous lightning in the area. Take shelter immediately. Repeat, dangerous lightning in the area. Take shelter immediately."	
Armed Person/ Intruder/ Dangerous Situation/Security Alert				
68	FWS-14022	Dangerous Situation on Campus	"Attention. Dangerous situation reported on campus. Take cover and stay in place until further information is provided. Repeat. Take cover and stay in place until further notice."	
69	FWS-14023	Lockdown	"Warning. This is a lockdown alert, please proceed to a secure area."	
70	FWS-14024	Armed Intruder on Campus	"Attention: An armed intruder has been seen on campus. Shelter in place immediately."	
71	FWS-14025	Gunshots Reported on Campus	"Attention: Gunshots reported on campus. Shelter in place until further notice. Repeat."	
Shelter in place until further notice.				
72	FWS-14026	Armed and Dangerous Person	"Attention! Armed and dangerous person alert. Seek a secure location."	
73	FWS-14027	Lock Down	"Warning. This is an order to lock down. Proceed to a secure location. Repeat, this is an order to lock down. Proceed to a secure location and wait for further instructions."	
Seek Shelter-Generic				
74	FWS-14028	Remain Sheltered	"Attention...Attention... Please remain in a sheltered area until further notice. Attention... Attention...Please remain in a sheltered area until further notice."	
75	FWS-14029	Seek Shelter	"Attention! Seek shelter immediately. Stay indoors"	
Chemical Release/Hazardous Material				
76	FWS-14030	Hazardous Material Release-Go inside	"Attention. Life threatening situation. A hazardous material release has occurred. Go inside. Close all windows and doors. Stay until further notice."	
77	FWS-14031	Hazardous Materials-Stay Inside	"Hazardous materials incident. Stay inside; close all doors and windows. Remain calm and wait for further instructions."	
78	FWS-14032	Chemical Release-Seek Shelter	"Warning. Chemical release, take shelter indoors. Repeat. Chemical release, take shelter indoors."	
79	FWS-14033	Chemical Release-Seek Shelter	"Attention! There has been a chemical release in the area. Go inside, close all windows and doors, turn off all heating and air conditioning. There has been a chemical release. Seek shelter now."	

Appendix A Standard DV Messages

#	FWS Name	Customer Name for DV	Description	Notes
80	FWS-14034	Shelter In Place	"Attention: Authorities have issued an alert to Shelter in Place due to a chemical release in the area. Tune to your local radio station for details."	
81	FWS-14035	Hazmat-Seek Shelter	"Attention. Attention. Hazardous condition. Seek shelter immediately and wait for the all clear."	
Evacuate				
82	FWS-14036	Evacuate To Safe Area	"Attention! Evacuate to a safe area."	
83	FWS-14037	Emergency Evacuate All Buildings	"Warning. This is an emergency evacuation order. Remain calm and evacuate all buildings; follow posted evacuation routes."	
84	FWS-14038	Emergency Evacuate All Buildings-Designated Gathering Area	"Attention. Attention. An emergency has been declared. Please evacuate all buildings immediately. Proceed to the nearest exit and go to your designated gathering area."	
85	FWS-14039	Evacuate Campus	"Warning. This is a campus evacuation order. All non-emergency personnel must leave campus immediately. Repeat, this is a campus evacuation order. Leave campus immediately."	
86	FWS-14040	Evacuate-Higher Ground	"Attention: Evacuate, Evacuate, Evacuate, Move to high ground immediately. Tune to your local radio station for details."	
87	FWS-14041	Mandatory Evacuation	"Warning. A mandatory evacuation has been issued effective immediately. Follow all emergency evacuation plans and evacuate at once. Personnel without transportation, stand by for additional information."	
88	FWS-14042	Evacuate-Do not use Elevator	"Attention! An emergency has been reported. Please evacuate the building immediately. Do not use the elevator."	
General Emergency/Other				
89	FWS-14043	Public Safety Emergency	"Public Safety Emergency. Please take shelter immediately and seek additional information from the campus emergency information network."	
90	FWS-14044	Emergency Pre-announcement	"Stand by for an important announcement from your local emergency agency."	
91	FWS-14045	General Emergency	"Emergency. Please stand by for further instructions."	
92	FWS-14046	Unsound Structures	"Warning. Warning. Do not attempt to enter unsound structures. Check your area for damage and avoid risk."	
93	FWS-14047	Power Outage	"There is a building-wide power outage. Avoid using open flames or candles during this outage."	

#	FWS Name	Customer Name for DV	Description	Notes
Public Address				
94	FWS-14048	Pre-Announcement for Live Broadcast-PA	"Attention! Attention! Stand by for an emergency announcement. Stand by for emergency information. Attention! Attention! Stand by for an emergency announcement. Stand by for emergency information."	
Fire				
95	FWS-14049	Fire-Wild Land Fire	"Wild land fire approaching. Remain calm and evacuate campus."	
96	FWS-14050	Fire Drill	"Attention this is a fire drill, report to your designated area."	
97	FWS-14051	Fire Alert	"Attention this a fire alert, report to your designated area."	
98	FWS-14052	Fire on Campus	"Fire on Campus-Please stand by for further instructions."	
99	FWS-14053	Fire Alarm Test Start	"Fire alarms are currently being tested. No evacuation of the building is necessary."	
100	FWS-14054	Fire Alarm Test Complete	"Fire alarm testing is complete. All alarms from this point forward should be treated as a real fire alarm and the building should be evacuated."	
Test				
101	FWS-14055	Test	"This is a test of the emergency warning system. This is only a test."	
102	FWS-14056	Test	"This is a test of the Campus Emergency Alert System. This is only a test. "	
103	FWS-14057	Test	"This is a test of the public warning system. This is only a test. If this had been an actual emergency, additional instructions would be broadcast. This is only a test."	
104	FWS-14058	Test	"Your attention please: This is a test. This is a test of the emergency warning system. This is a test and only a test. There are no emergency situations in our area. Thank you."	
105	FWS-14059	Test	"Attention: This is a test of the emergency warning system. This is only a test. If this were an actual emergency, you would be instructed to tune to your local radio station. This is only a test."	
All Clear				
106	FWS-14060	All Clear	"Attention. This is an all clear, repeat all clear."	
107	FWS-14061	All Clear	"Attention! All clear. All clear. Resume normal activities."	
Closed				
108	FWS-14062	University Closed	"Attention: The University is now closed. Tune to local media for further information."	

Appendix A Standard DV Messages

#	FWS Name	Customer Name for DV	Description	Notes
Armed Forces Songs				
109	FWS-14063	Army Song	"Army Song Band and Chorus"	
110	FWS-14064	Navy Song	"Anchors Aweigh"	
111	FWS-14065	Air Force	"The Air Force Song"	
112	FWS-14066	Marine Corp	"The Marines' Hymn"	
113	FWS-14067	Coast Guard	"Semper Paratus"	
114	FWS-14068	Army Song	"The Army Goes Rolling Along"	
115	FWS-14069	National Anthem	"National Anthem" 80 sec.	
Armed Forces Sounds-Bugle Call				
116	FWS-14070	Adjutant's Call	"Adjutant's Call"	
117	FWS-14071	Assembly	"Assembly"	
118	FWS-14072	Attention	"Attention"	
119	FWS-14073	Army Song	"Call to Quarters"	
120	FWS-14074	Church Call	"Church Call"	
121	FWS-14075	Drill Call	"Drill Call"	
122	FWS-14076	First Call	"First Call"	
123	FWS-14077	First Sergeants Call	"First Sergeants Call"	
124	FWS-14078	Fix Bayonets	"First Bayonets"	
125	FWS-14079	Taps	"Taps"	
126	FWS-14080	Carry On	"Carry On"	
127	FWS-14081	Retreat	"Retreat"	
128	FWS-14082	Ground Attack Charge	"Ground Attack Charge"	
129	FWS-14083	Guard Mounting	"Guard Mounting"	
130	FWS-14084	Mail Call	"Mail Call"	
131	FWS-14085	Mess Call	"Mess Call"	
132	FWS-14086	Morning Colors	"Morning Colors"	
133	FWS-14087	Officer's Call	"Officers Call"	
134	FWS-14088	Recall	"Recall"	
135	FWS-14089	Reveille	"Reveille"	
136	FWS-14090	Slow Retreat Bugle Call	"Slow Retreat Bugle Call"	
137	FWS-14091	Tattoo	"Tattoo"	
138	FWS-14092	To the Colors	"To the Colors"	
139	FWS-14093	Evening Slow Colors	"Evening Slow Colors"	
PAGASYS GEN II FILES				
140	FWS-14094	800Hz 1 sec on 1 sec off	800 Hz 1 sec on 1 sec off	
141	FWS-14095	Alt Tone Hi Low	Alt Tone Hi Low	
142	FWS-14096	Alternating Tone	Alternating Tone	

#	FWS Name	Customer Name for DV	Description	Notes
143	FWS-14097	Bell Continuous IMO General Alarm	Bell Continuous IMO General Alarm	
144	FWS-14098	Bell IMO PAPA BELL 7x SHORT	Bell IMO PAPA BELL 7x SHORT 1x Long	
145	FWS-14099	Bell Intermittent IMO Gas 1 sec ON 1 sec OFF	Bell Intermittent IMO Gas 1 sec ON 1 sec OFF	
146	FWS-14100	Chime Test Tone	Chime Test Tone	
147	FWS-14101	Continuous Tone PFEER Toxic Gas Alarm 1 kHz signal	Continuous Tone PFEER Toxic Gas Alarm 1 kHz signal	
148	FWS-14102	Duck and Cover	Duck and Cover	
149	FWS-14103	Emergency Shutdown	Emergency Shutdown	
150	FWS-14104	Gas Detected	Gas Detected	
151	FWS-14105	General Alarm 7 short 1 long 30 sec 1 khz	General Alarm 7 short 1 long 30 sec 1 khz	
152	FWS-14106	Intermittent Tone PFEER General Alarm 1 kHz signal 1 sec ON 1 sec OFF	Intermittent Tone PFEER General Alarm 1 kHz signal 1 sec ON 1 sec OFF	
153	FWS-14107	Low Freq 2 Tone	Low Freq 2 Tone	
154	FWS-14108	"Abandon Platform"	"Abandon Platform"	
155	FWS-14109	"All Clear"	"All Clear"	
156	FWS-14110	"Man, Over Board"	"Man, Over Board"	
157	FWS-14111	"This is a test of the Alarm System"	"This is a test of the Alarm System"	
158	FWS-14112	"This is a test of the General Alarm"	"This is a test of the General Alarm"	
159	FWS-14113	Pfeer PAPA	Pfeer PAPA	
160	FWS-14114	Pre-Announce Chime ASC Tri Tone Routine ALT1	Pre-Announce Chime ASC Tri Tone Routine ALT1	
161	FWS-14115	Process Alarm	Process Alarm	
162	FWS-14116	Process Shutdown	Process Shutdown	
163	FWS-14117	Process Classified	Process Classified	
Additions				
164	FWS-2599	Test End	"This has been a test of the emergency warning system. This was only a test."	

Table 12 UTM Tones

Additions

#	FWS Name	Customers name for DV	Description	Notes
165	FWS-19241	TM1	(180 sec) Wail-Conventional Siren 560-1055Hz	
166	FWS-19242	TM2	(180 sec) Yelp-Rapid Siren 560-1055Hz	
167	FWS-19243	TM3	(180 sec) High-Low-Alternating High and Low 561Hz and 760Hz	
168	FWS-19244	TM4	(180 sec) Bell-Bell, Struck Rapidly-801Hz	
169	FWS-19245	TM5	(180 sec) Yeow-Descending High to Low, Repeated 545Hz and 1296Hz	
170	FWS-19246	TM6	(180 sec) Horn-Steady Horn	470Hz
171	FWS-19247	TM7	(180 sec) Beep-Slow Intermittent Horn 470Hz	
172	FWS-19248	TM8	(180 sec) Stutter-Rapid Intermittent Horn 470Hz	
173	FWS-19249	TM9	(180 sec) Slow Whoop-Slow Ascending Low to High, Repeated 424Hz and 1163Hz	
174	FWS-19250	TM10	(180 sec) Gradual Horn-Steady Horn, Gradually Increasing in Volume 514Hz	
175	FWS-19251	TM11	(180 sec) Temporal Slow Whoop-NFPA Coded Slow Whoop 424Hz and 774Hz	
176	FWS-19252	TM12	(9 sec) Westminster Chime-Westminster Chime-Musical Tone	
177	FWS-19253	TM13	(180 sec) Evac-Amplitude Modulated Siren 479Hz	
178	FWS-19254	TM14	(180 sec) Air Horn-Steady Horn 400Hz and 800Hz	
179	FWS-19255	TM15	(180 sec) Chime-Single Strike Chime-Musical Tone	
180	FWS-19256	TM16	(180 sec) Phaser-Rapid Siren	600-1200Hz
181	FWS-19257	TM17	(180 sec) Alternating High and Low 363Hz and 518Hz	
182	FWS-19258	TM18	(180 sec) Warble-Extremely Rapid Siren 560-1055Hz	
183	FWS-19259	TM19	(180 sec) Alert-Slow Sweep Tone 400-1560Hz	
184	FWS-19260	TM20	(180 sec) Euro-Police-Alternating High and Low 969Hz and 800Hz	
185	FWS-19261	TM21	(180 sec) Euro-Fire Sweep Tone 900-800Hz	
186	FWS-19262	TM22	(180 sec) Euro-Slow Whoop-Slow Sweep Tone 650-1290Hz	
187	FWS-19263	TM23	(180 sec) Euro-General-Intermittent Horn 969Hz	
188	FWS-19264	TM24	(180 sec) Euro-Toxic-Steady Horn 969Hz	
189	FWS-19265	TM25	(180 sec) Euro-Police II-Slow Alternating High and Low 554Hz and 440Hz	
190	FWS-19266	TM26	(180 sec) Euro-Stutter-Intermittent Beep 2840Hz	
191	FWS-19267	TM27	(180 sec) Euro-Sweep-Sweep Tone 1163 - 397Hz	
192	FWS-19268	TM28	(180 sec) Ringer-Continuous Ringing Tone 560Hz and 326Hz	
193	FWS-19269	TM29	(180 sec) Buzzer-Buzzer Tone 1318Hz and 760Hz	

#	FWS Name	Customers name for DV	Description	Notes
194	FWS-19270	TM30	(180 sec) Attention-Extremely Rapid Siren-Multiple Frequency	
195	FWS-19271	TM31	(180 sec) Multi-Tone-Extremely Rapid Siren-Multiple Frequency	
196	FWS-19272	TM32	(180 sec) Caution-Extremely Rapid Siren-Multiple Frequency	



FEDERAL SIGNAL
Safety and Security Systems

2645 Federal Signal Drive
University Park, Illinois 60484

www.fedsig.com

Customer Support

1-800-344-4634 • +1-708-534-4756

Technical Support

1-800-755-7621 • +1-708-587-3587