

25500210 Rev A1 0722

Safety Message to Installers of Warning Light Equipment

▲ WARNING

People's lives depend on your proper installation and servicing of Federal Signal products. It is important to read and follow all instructions shipped with this product and the original product. Listed below are some other important safety instructions and precautions you should follow:

- To properly install the lighting and siren systems, you must have a good understanding of automotive systems, along with proficiency in the installation and use of safety warning equipment.
- Do not install equipment or route wiring in the deployment path of an airbag.
- If a vehicle seat is temporarily removed, verify with the vehicle manufacturer if the seat needs to be recalibrated for proper airbag deployment.
- Frequently inspect the light and siren systems to ensure that they are operating properly and are securely attached to the vehicle.
- When drilling into a vehicle structure, ensure that both sides of the surface are clear of anything that could be damaged.
- Refer to the instructions packed with related products for additional precautions and information.
- Do not stare directly into the lights at a close range, or permanent damage to your eyesight may occur.
- All effective sirens and horns produce loud sounds (120 dB) that may cause permanent hearing loss. Always minimize your exposure to the sound of the siren and horn and wear hearing protection. Do not sound the siren and horn indoors or in enclosed areas where you and others will be exposed to the sound.
- File these instructions in a safe place and refer to them when maintaining and/or reinstalling the product.

Failure to follow all safety precautions and instructions may result in property damage, serious injury, or death.

Overview of the Gutter Hook Kits

Before proceeding, read and understand all instructions provided with the mounting kit. This installation requires parts provided in the mounting kit. These instructions supersede any conflicting generic instructions in the mounting kit. For electrical installation instructions, refer to the installation and maintenance instructions packed with the light bar.

NOTE: Before the installation, read and understand the Ford SVE QVM Bulletin Q-222 "Attaching Accessories to Aluminum Panels and Structure" available on the website of the Ford Truck Body Builder Advisory Service at <https://www.fleet.ford.com/truckbbas/non-html/Q-222.pdf>

Mounting Instructions for Gutter Hook Kits

Unpacking the Kit

After unpacking the kit, inspect it for damage that may have occurred in transit. If it has been damaged, do not attempt to install or operate it. File a claim immediately with the carrier, stating the extent of the damage. Carefully check all envelopes, shipping labels, and tags before removing or destroying them. Ensure that the parts in Table 1 are included in the package. If you are missing any parts, contact Customer Support at 1-800-264-3578, 7 a.m. to 5 p.m., Monday through Friday (CT).

Table 1 Kit contents

Qty.	Description	Part Number
2	Hook	Varies
2	Pad, Bumper, Hook	8552492
6	Rivet, Pop, 3/16" Diameter, Aluminum	7099220-27

Prepare the Gutter Hooks

⚠ WARNING

AIRBAG DEPLOYMENT: Do not install equipment or route wiring in the deployment path of an airbag. Failure to observe this warning will reduce the effectiveness of the airbag or potentially dislodge the equipment, causing serious injury or death.

⚠ WARNING

DRILLING PRECAUTION: When drilling holes, check the area you are drilling into to ensure that you do not damage vehicle components. All drilled holes should be deburred, and all sharp edges should be smoothed. All wire routings going through drilled holes should be protected by a grommet or convolute/split loom tubing.

⚠ WARNING

HEAVY OBJECT: Use lifting aids and proper lifting techniques when removing or replacing this product. Failure to follow this warning may cause personal injury.

IMPORTANT: Plan all cable routing before the installation.

To prepare the gutter hooks:

1. To protect the roof surface, peel the backing from the adhesive mounting pad, and attach the pad to the bottom of each hook. See Figure 1.

Figure 1 Pad attached to mounting hook

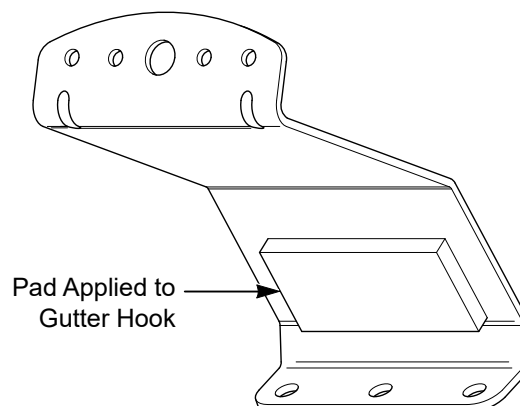

2. With parts from the mounting kit, using a 5/16-inch bolt as an alignment guide, install the washer with a screw on both hooks. See Figure 2.

Figure 2 Washer attached to mounting hook

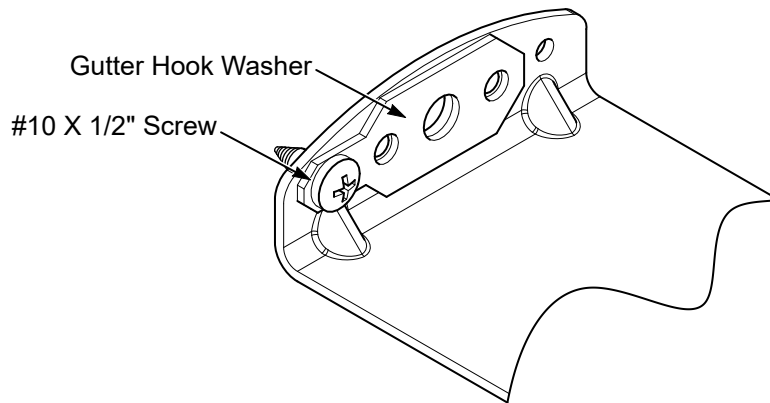

Prepare the Mounting Foot (INTG/LGD/LPX/NVG)

Install the pads to the mounting foot using the parts supplied with the light bar mounting kit.

- **For the 51-inch Integrity/53-inch Legend/LPX/Navigator:** Use the thickest pad to the front and the medium pad to the rear.
- **For the 44-inch Integrity/45-inch Legend/LPX/Navigator:** Use the medium pad to the front and the thinnest pad to the rear.

Prepare the Light Bar

To prepare the light bar:

1. Place the light bar on the vehicle, centered left to right.
2. Adjust the feet in or out as shown in Figure 3.

Figure 3 Mounting foot position

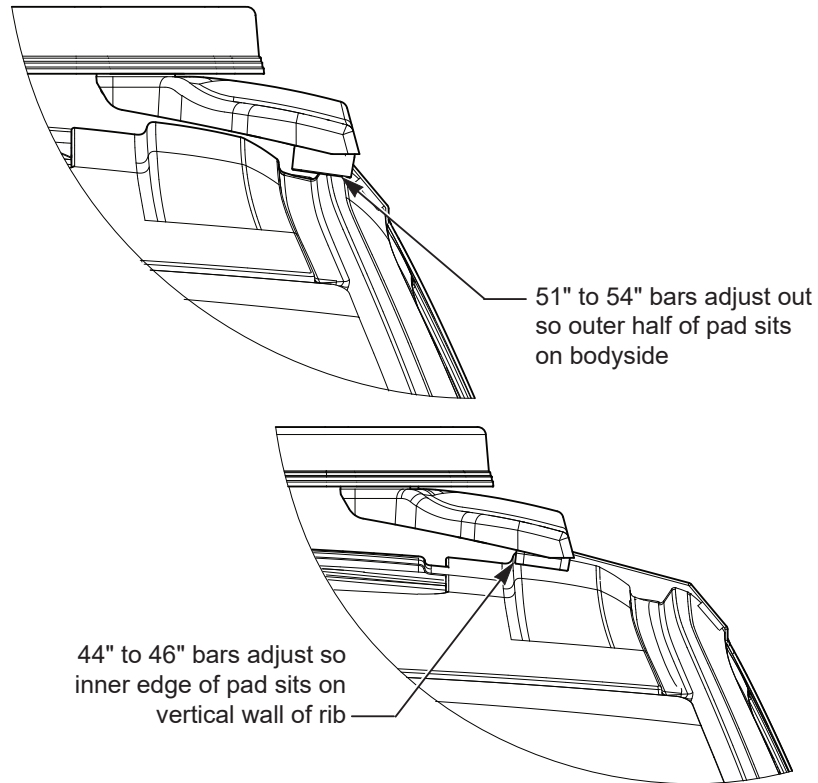

3. Tighten the nuts on the mounting feet to the torque recommended in the mounting kit instructions.

Attach the Light Bar to the Vehicle

To attach the light bar:

1. Lift the light bar and attach the hook assemblies to the light bar with the 5/16-18 hex head bolt of the appropriate length. Start the bolt with only two or three turns.
2. Place the hooks in position on the bodysides. See Figure 4 for the Crew/Super cab. See Figure 5 for the regular cab. Verify and adjust the position as necessary.

Figure 4 Crew and super hook position

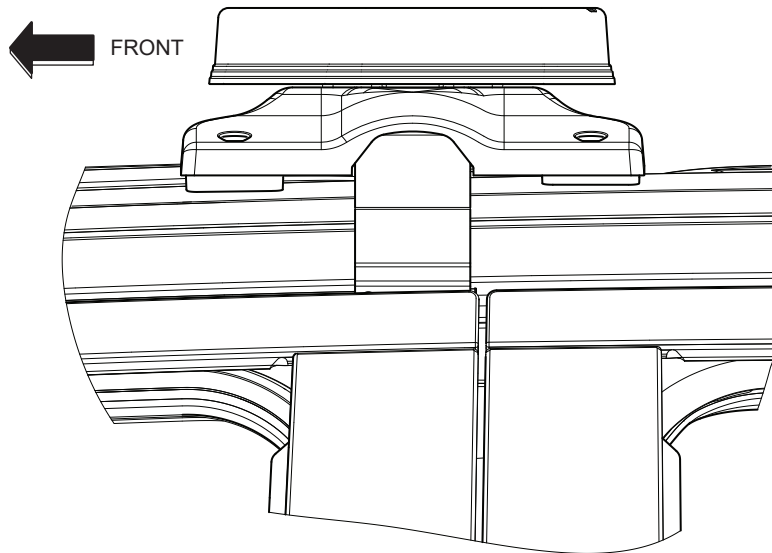
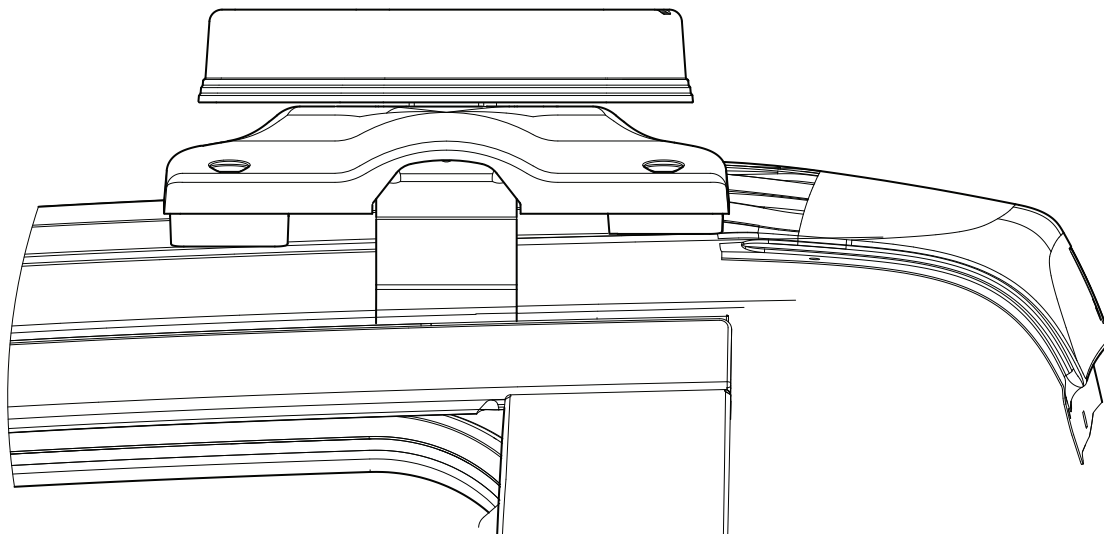

Figure 5 Regular cab hook position



3. Using the hook as a template, mark and drill three 0.187-inch (3/16-inch) holes.
4. Secure the hook using three of the 3/16-inch rivets. If the mandrel of the rivet does not break flush or recessed, dress the end flush to prevent damage to the weatherstrip over time. Repeat for the other side.

Mounting Instructions for Gutter Hook Kits

5. Adjust the level of the light bar.
 - **For the Vision SLR:** Adjust the light bar for a slight (approx. 1/8-inch to 1/4-inch) nose-down pitch.
 - **For the Valor:** Adjust the light bar level to slightly nose-down (approx. 1/8 inch).
6. Alternating side-to-side to keep the light bar centered, snug the 5/16-inch bolts just until the light bar feels solid when you lift on the mounting feet. Do not overtighten.
7. With parts from the mounting kit, install the keeper plates with two screws each.

Completing the Installation

1. Complete the installation according to the instructions provided with the light bar

⚠ WARNING

LIGHT HAZARD: To be an effective warning device, an emergency warning system produces bright light that can be hazardous to your eyesight when viewed at a close range. Do not stare directly into the lights at a close range, or permanent damage to your eyesight may occur

2. Test the lights for proper operation.

Getting Technical Support

For technical support, please contact:

Federal Signal Corporation
Service Department
Phone: 1-800-433-9132
Email: empSERVICEinfo@fedSIG.com

Getting Repair Service

The Federal Signal factory provides technical assistance with any problems that cannot be handled locally. Any units returned to Federal Signal for service, inspection, or repair must be accompanied by a Return Material Authorization (RMA). Obtain an RMA from a local Distributor or Manufacturer's Representative. Provide a brief explanation of the service requested or the nature of the malfunction.

Address all communications and shipments to the following:

Federal Signal Corporation
Service Department
2645 Federal Signal Dr.
University Park, IL 60484-3167

Ordering Replacement Parts

To order replacement parts, call Customer Support at 1-800-264-3578, 7 am to 5 pm, Monday through Friday (CT), or contact your nearest distributor.

Limited Warranty

This product is subject to and covered by a limited warranty, a copy of which can be found at www.fedSIG.com/SSG-Warranty. A copy of this limited warranty can also be obtained by written request to Federal Signal Corporation, 2645 Federal Signal Drive, University Park, IL 60484, email to info@fedSIG.com or call +1 708-534-3400.

This limited warranty is in lieu of all other warranties, express or implied, contractual or statutory, including, but not limited to the warranty of merchantability, warranty of fitness for a particular purpose and any warranty against failure of its essential purpose.



FEDERAL SIGNAL
Safety and Security Systems

2645 Federal Signal Drive
University Park, Illinois 60484-3167

www.fedsig.com

Customer Support

Police/Fire-EMS: 800-264-3578 • +1 708 534-3400

Work Truck: 800-824-0254 • +1 708 534-3400

Technical Support 800-433-9132 • +1 708 534-3400

All product names or trademarks are properties of their respective owners.

© Copyright 2017-2022 Federal Signal Corporation