

Manual Call Point Pushbutton and Break Glass Stations For Use in Hazardous Locations



Federal Signal Models CP-PB, CP-BG

Installation and Maintenance Instructions

Limited Warranty

This product is subject to and covered by a limited warranty, a copy of which can be found at www.fedsig.com/SSG-Warranty. A copy of this limited warranty can also be obtained by written request to Federal Signal Corporation, 2645 Federal Signal Drive, University Park, IL 60484, email to info@fedsig.com or call +1 708-534-4756.

This limited warranty is in lieu of all other warranties, express or implied, contractual or statutory, including, but not limited to the warranty of merchantability, warranty of fitness for a particular purpose and any warranty against failure of its essential purpose.



Signaling Devices

2645 Federal Signal Drive
University Park, IL 60484-3167
Tel: 708-534-4756
Tech Support Tel: 708-587-3587
Email: signalsupport@fedsig.com
www.fedsig.com

Contents

Safety Messages to Installers and Users	5
Certifications, Conditions of Use	6
Model Descriptions and Accessories	7
Unpacking the Call Points Station	9
Opening the Call Point for Internal Access	9
Front Chamber Access (glass replacement, cover attachment)	9
Rear Chamber Access (mounting, wiring of station)	11
Mounting the Call Point Station	12
Safety Messages for Installation & Wiring	13
Internal Rear Chamber Wiring	14
Standard SPDT & DPDT Switch Wiring	16
Optional EOL, Diode & Series Resistor Module Install & Wiring	16
Optional Bi-Color LED Status Indicator Wiring	17
Electrical Specifications of the Call Point Station	20
Manual Test & Reset Operation of the Station	21
CP-PB Push Button Stations	21
CP-BG Break Glass Stations	22
Safety Messages to Maintenance Personnel	24
Maintaining / Modifying the Call Point Station	25
Cleaning the Enclosure	25
Replacing the Break Glass Panel (CP-BG units)	25
Installing/Serviceing the Reset Keyway	27
Installing/Serviceing Optional Cover Flap	28
Serviceing the LED Module	29
Installing/Serviceing the Break Glass Hammer Bar	31
Installing/Serviceing the Optional Stainless Steel Faceplate Labels ..	31
Installing/Serviceing the Optional Stainless Steel Duty Plates ..	32
Lubricating the Threaded Joints..	33
Ordering Accessory Parts/Service Kits	33
Getting Technical Support & Service	36

Contents

Wiring Schematics

Figure A	Schematic: Standard SPDT Switch Wiring	16
Figure B	Schematic: Standard DPDT Switch Wiring	16
Figure C	Schematic: SPDT with Optional Series Device Module Wiring	17
Figure D	Schematic: DPDT with Optional EOL Resistor Module Wiring	17
Figure E	Schematic: DPDT with Optional LED Module Wiring.....	18

Tables

Table 1	Fire Alarm Control Panel Impedance for LED Models	19
Table 2	Field Installed Service / Accessory Kits	34-35

© 2019 Federal Signal Corporation. All rights reserved.

Installation and Maintenance Instructions

Safety Messages to Installers and Users



It is important to follow all instructions shipped with this product. This Call Point station is to be installed by a trained electrician who is thoroughly familiar with and will follow all applicable national and local codes in the country of use.

This Call Point station should be considered a part of the warning system and not the entire warning system.

The selection of the mounting location for the Call Point station, its controls and the routing of the wiring are to be accomplished under the direction of the facilities engineer and the safety engineer. In addition, listed below are some other important safety instructions and precautions you should follow:

- Read and understand all instructions before installing or operating this equipment.
- To avoid electrical shock hazards, do not connect wires when power is applied. **Failure to observe this warning may lead to serious injury or death.**
- Never alter the unit in any manner. Safety in hazardous locations may be endangered if additional openings or other alterations are made in units specifically designed for use in these locations.
- Do not connect this station to the system when power is on.
- After installation, ensure that all threaded joints are properly tightened.
- Keep the unit tightly closed when in operation.
- After installation, test the station and the system to ensure that it is operating properly.
- After testing is complete, provide a copy of this instruction sheet to all personnel.
- Establish a procedure to routinely check the station and system for proper activation and operation.

Failure to follow all safety precautions and instructions may result in property damage, serious injury, or death.

Installation and Maintenance Instructions

Certifications

ATEX and IECEx Certification Information:

Certificate Nos.: ATEX Cert No.: DEMKO 19 ATEX 1939X
IECEx Cert No.: IECEx UL 19.0074X

ATEX coding:  II 2 G D
Protection: II 2 G Ex db eb mb IIC T4 Gb (Tamb= -40°C to +70°C)
CP-BG models: II 2 D Ex tb IIIC T100°C Db IP66
CP-PB models: II 2 D Ex tb IIIC T100°C Db IP66

EN60079-0, EN60079-1, EN60079-7, EN60079-18, EN60079-31,
IEC60079-0, IEC 60079-1, IEC60079-7, IEC60079-18, IEC 60079-31

Refer to Certificates for specific standard versions.

Specific Conditions of Use:

1. *The equipment has an optional protective non-metallic cover which may provide a potential electrostatic charging hazard.*
2. *The equipment has an optional metallic break glass hammer mounted to the enclosure which can store electrical charge and therefore may provide a potential electrostatic charging hazard. The metallic break glass hammer has a capacitance of 94pF.*
3. *These devices reach a temperature of 85°C at entry point.*

Construction Products Regulation (CPR) Certification Information:



1. Model Designation: CP-BG-x-x-x-xxx-xx-x
2. Description: Manual call point for fire detection and fire alarm systems for buildings.
3. Declaration of Performance No.: 0843-CPR-0453. (To access it: Go to www.fedsig.com, search model "CP-BG" to access product webpage, click "Resources" tab. The document is located under "Agency Certificates" section)
4. Standard Applied: EN54-11:2001/A1:2005.
5. Identification Number of Notified Product Certification Body: 0843.
6. Manufacturer: Federal Signal, 2645 Federal Signal Drive, University Park, IL 60484
7. Marking Year: 2018

Conditions for Safe Use:

1. This device has been tested for a voltage range of $\pm 10\%$.
2. Do not install Test Reset Key. Key may only be installed for applications not requiring EN54-11 certification.
3. To enable correct installation and operation, review all sections in this manual #25500424A for all technical, installation, and maintenance data.

Installation and Maintenance Instructions

Model Descriptions and Accessories

Federal Signal Manual Call Points Stations are available in two base models (PB – Push Button & BG – Break Glass) both providing the following **standard and field customizable features**:

- High-impact resistant glass-reinforced polyester (GRP) thermoset plastic housing & faceplate for corrosion resistance
- -40°C to 70°C ambient operational coverage
- Static-dissipative GRP housings & faceplates
- One or two switches available (two switches unavailable with LED option factory installed)
- Three M20 or ½" NPT threaded entryways
- 180° rotatable rear housing with respect to front housing for top or bottom dual conduit feeds, with a single left or right feed.
- Color-coded front replaceable faceplate (red, yellow, green, blue, black)
- Front face visual status indicator (white triangles)
- Reset keyway which may be installed on unit or used separately

Note: CP-BG-x-x-x-xxx-xx-2 (EN 54-11) models will NOT have the keyway installed in actual applications, it is only to be used separately as a discrete keyway and will be included separately as such.

- Removable internal wiring block/mounting plate for wiring ease, if desired
- Input wiring block types available:
 - 9-position cage-clamp design, or a
 - 9-position screw-down design
- Faceplate labels:
 - 8 adhesive backed labels are supplied for field install: FIRE, EVAC, BIOHAZARD, GAS, EMERGENCY, SHUTDOWN, LOCKDOWN, and Evac Logo (white or black on clear background)
 - Stainless steel faceplate labels available as an option (separate service part # for field install) for: 'FIRE', 'EVAC', 'GAS ALARM', or 'BIOHAZARD ALARM' (black text on stainless steel background)
 - **Special applications** (ex: language, specific artwork, site location, etc...): the faceplate's labelling surface will accept end – user supplied Uline 1.75" x ½" weather resistant labels for laser printers, Uline part # S-19297
 - Custom stainless steel Duty Label (separate service part # for field install): side mounted on either PB or BG units (except BG units that have a break glass hammer bar already installed). Consult factory for lead times as this is a customized part for end-user specific install

Installation and Maintenance Instructions

Model CP-PB Call Point Push Button activated

- 1-3/4" (44.5mm) diameter spring return black thermoset plastic push button
- Protective faceplate wall shroud about the button and status indicator
- Optional bi-color LED status light indicator



Model CP-BG Call Point Break Glass activated

- Replaceable break glass panel covered with a protective polyester label to limit glass particle fallout
- Protective faceplate wall shroud about the status indicator
- EN 54-11 approved British Standard model available (Note: Reset Keyway must not be installed during operation)
- Optional side mounted break glass hammer bar
- Optional bi-color LED status light indicator



Federal Signal Manual Call Point Stations are available with the following optional features factory installed:

- 6v, 12v, 24v or 48v LED bi-color status indicator
- High-impact resistant clear polycarbonate cover flap with or without various instructional labels (ex: "LIFT COVER, BREAK GLASS TO ACTIVATE") on interior face of the cover flap.
- Side mounted stainless steel break glass hammer bar on BG stations
- Single and dual switches
- EN54-11 certified Break Glass stations

Federal Signal Manual Call Point Station may be field serviced with the Service/Accessory Kits specified within Table 2 on pages 34-35.

Installation and Maintenance Instructions

Unpacking the Call Points Station

After unpacking the station, examine it for damage that may have occurred in transit. If it has been damaged, do not attempt to install or operate it. File a claim immediately with the carrier, stating the extent of the damage. Carefully check all envelopes, shipping labels, and tags before removing or discarding them. Disposal of all shipping materials must be carried out in accordance with national and local codes and standards. If any parts are missing, please call Federal Signal Customer Support at +1 708-534-4756 or +1 800-446-6809.

Opening / Closing the Call Point for Internal Access

The Federal Signal Call Point stations have two chambers within their designs, the first being a front chamber housing the stainless steel mechanical hardware; and the rear chamber housing the activation switch, and an internal wiring block with housing provisions for M8 or ¼" mounting hardware through the four corner slotted openings. NOTE: The design is such that the rear chamber may be accessed with no need to open the front chamber.

Tools needed to access both chambers:

- #2 Philips drive screwdriver
- 2.0 mm hexagon key
- 3.0 mm hexagon key

Call Point Front Chamber Access

Model CP-PB pushbutton station's front chamber is easily accessed for cover flap attachment and/or maintenance or replacement of parts by the following actions:

- Remove the pushbutton and bearing washer by unscrewing the ¾" long Philips head screw.
- If present, remove the reset keyway by using a M2 hex wrench to loosen the M4 set screw below the keyway's triangular pointer
- Unloosen the two M4 Philips head screws at the 3:00 and 9:00 positions on the faceplate and remove the faceplate. NOTE: these two screws are captivated to the front faceplate.
- Upon reinstalling the front faceplate, reverse this process and apply 15" in*lbs (1.7 N*m) maximum of torque to the M4 Philips head screws to insure the faceplate is fully seated on the front housing. NOTE: applying excessive torque may result in the brass threaded insert dislodging from the front housing rendering the unit inoperable.
- Model CP-BG break glass station's front chamber is easily accessed by the following actions:
 - If present, remove the reset keyway by using an M2 hex wrench to loosen the M4 set screw below the keyway's triangular pointer

Installation and Maintenance Instructions

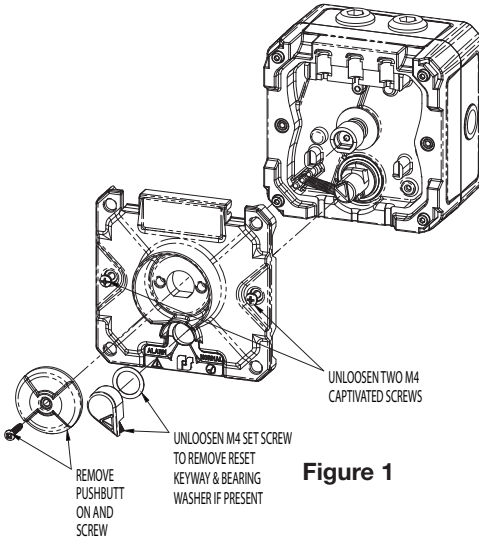

Figure 1

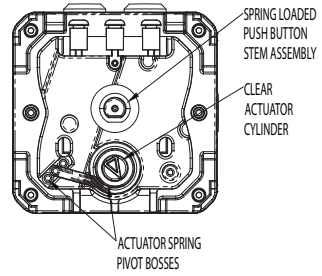

Figure 2

- Unloosen the two M4 Philips head screws at the 3:00 and 9:00 positions on the faceplate and remove the faceplate. NOTE: these two screws are captivated to the front faceplate
- Upon reinstalling the front faceplate, apply 15" in*lbs (1.7 N*m) maximum of torque to the M4 Philips head screws to insure the faceplate is fully seated on the front housing. NOTE: applying excessive torque may result in the brass threaded insert dislodging from the front housing rendering the unit inoperable.

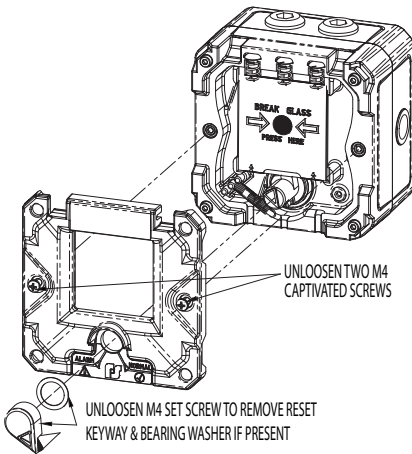

Figure 3

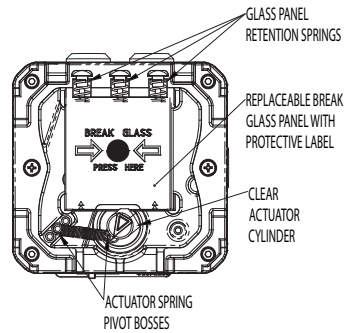

Figure 4

Installation and Maintenance Instructions

Call Point Rear Chamber Access

All models of the Call Point station have the same rear chamber access method for internal wiring management, mounting the unit to a vertical wall surface, and general maintenance/routine inspection.

- Unloosen the four captivated socket head cap M4 screws by using a M3 hex wrench at each of the front corners of the device.
- Carefully pull away the front housing portion from the rear, noting the limited extension length of the two halves due to the wiring harness length.
- Note that the rear housing unit is 180° rotatable with respect to the front housing so the two threaded entryways can be on either the top or bottom of the installed station.
- Upon reinstalling the front housing, screw down a pair of diagonally opposed screws first by partially applying 18" in*lbs (2.0 N*m) maximum of torque to the M4 socket head screws. Repeat the process to the other two diagonally opposed screws, and then return back to the first two repeating the process in order to evenly tighten the station to insure the housing is fully seated on the gasket. **NOTE:** applying excessive torque may result in the brass threaded insert dislodging from the rear housing rendering the unit inoperable.

Common Internal View

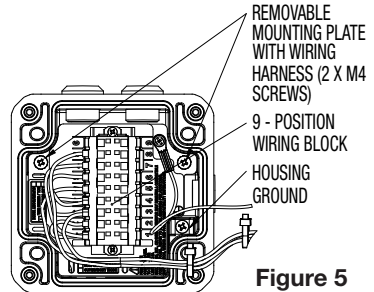
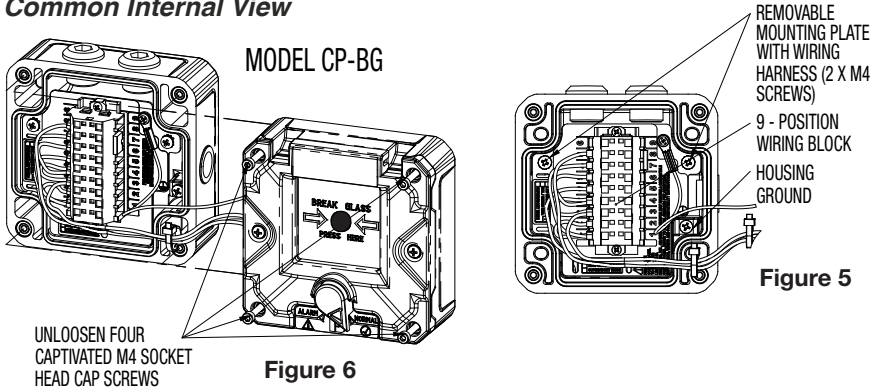
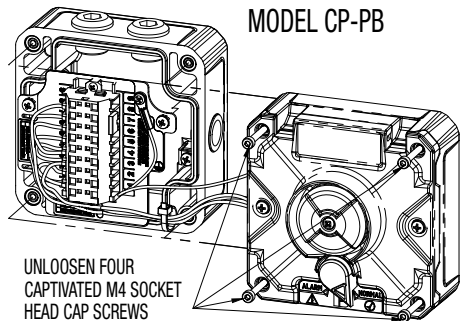

Figure 6

Figure 7



Installation and Maintenance Instructions

Mounting the Call Point Station

⚠ WARNING

ATTACH THE STATION SECURELY: *To prevent injury, this apparatus must be securely attached to the mounting surface in accordance with the installation instructions and local jurisdictions and codes. Use installer-supplied fasteners suitable for the mounting surface.*

All models of the Call Point station have the same rear chamber access to four corner oval-shaped holes for mounting the station to a rigid vertical wall surface. The devices may be mounted by using four M6 metric threaded fasteners, or four ¼" or #12 threaded fasteners which are installer-supplied. Be sure to follow all national and local jurisdictions and codes as to placement of the station within the appropriate environment.

Mounting Layout

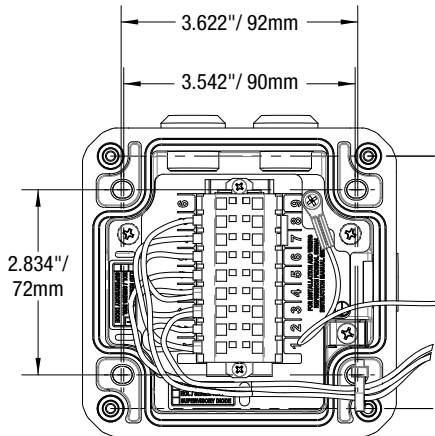

Figure 8

Installation and Maintenance Instructions

Safety Messages for Installation & Wiring

When installing and operating the stations, the relevant national regulations for installation and operation (e.g., EN60079-14, IEC Wiring Regulations and NEC/CEC) along with any additional national and local codes/requirements must be observed.

WARNING

- To avoid electrical shock hazards, do not connect wires when power is applied. **Failure to observe this warning may lead to serious injury or death.**
- Painting, and surface finishes, other than those applied by Federal Signal Corporation, are not permitted.
- Wiring terminations should be in accordance with specifications within this manual and required by national & local requirements dependent upon the application. Federal Signal recommends that all wiring leads be fully identified.
- In all countries, the wiring must comply with all national and local codes and standards.
- Ensure that all hardware connections are secure. Stainless steel fasteners must be used in corrosive environment applications mounting the station to a rigid surface.
- Ensure that all cable glands, stopping plugs are certified with a suitable sealing washer/o-ring to insure the NEMA/IP rating of the station.
- The internal earth ground terminal must be used for equipment grounding where and when required.

Installation and Maintenance Instructions

Internal Rear Chamber Wiring

⚠ WARNING

SHOCK HAZARD:

To avoid electrical shock hazards, do not connect wires when power is applied. Failure to observe this warning may lead to serious injury or death.

All Federal Signal Call Points stations **are supplied with a standard nine-position wiring block** mounted to a removable aluminum bracket for wiring ease if desired. Multiple factory pre-terminated wiring layouts are available dependent upon the options that the station will have installed:

- Wire gauge range is 0.5 to 4.0 mm², (12-20 AWG) for either solid or stranded conductors.
- Strip length of 9 - 10 mm (0.35 – 0.39 in)

There are two factory installed wiring alternatives to the Federal Signal Call Points stations, **a factory installed case clamp wiring block is available, or a screw-down terminal block** mounted to the removable aluminum bracket for additional wiring ease or code requirement is available.

- Wire gauge range is 0.5 to 4.0 mm², (12-22 AWG) for either solid or stranded conductors.
- Strip length of 8 mm (0.315 in)

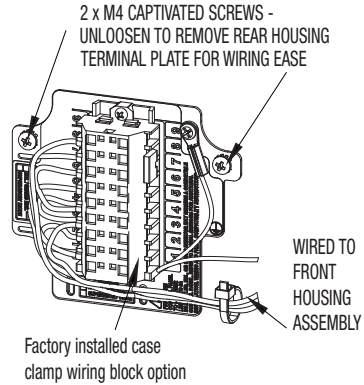

Figure 9

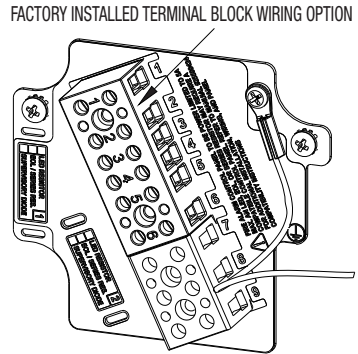

Figure 10

Installation and Maintenance Instructions

For both available wiring configurations:

- The cross-sectional area of the primary earth (ground located within the rear housing) must equal the cross-sectional area of the phase conductor.
- The incoming wire must be rated per the corresponding national and local codes in which the station is used.

Tools needed (after internal access):

- Wire stripper
- 4.0 x 0.8 mm or 1/8" slotted screwdriver

To wire the CP-PB (push button) and CP-BG (break glass) models:

1. If desired for easier access, unloosen the two captivated M4 Philips head screws on the aluminum mounting bracket & remove it from the rear housing, taking care as it still remains directly wired to the front housing assembly.
2. Strip the incoming wiring leads to the station to the length as noted above (dependent upon wiring block configuration). NOTE: insure that the incoming lead lengths into the station meet the required national and local regulations/codes, and also that the leads are not excessive in length causing the station not to be reassembled.

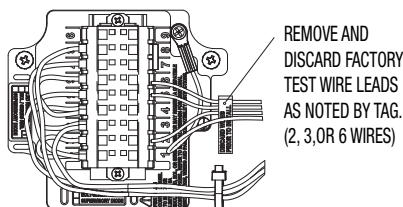

Figure 11

3. Remove the 22 AWG factory test leads (as noted by tag around them) from the terminal wiring block and discard them.
4. Reference the following wiring schematic diagrams for your station and its application within your system. Wire per diagram shown.
5. Insure all wires are properly seated and restrained to the station's wiring or terminal block.
6. Route/tuck in the wiring into the rear housing of the unit and carefully re-assemble the unit's front and rear housings so that both fully seat to each other when the four M4 socket head screws are tightened. Alternate between tightening the diagonal pairs of screws to insure the station's housings are tightened evenly together.

Installation and Maintenance Instructions

Standard SPDT & DPDT Devices Switch Wiring:

For the standard issue SPDT & optional DPDT models, please note the following applicable requirements for these specific models:

- A factory installed jumper is supplied across input terminals 7 & 8 of the single pull double throw switch device; on a double pull double throw device, input terminals 6, 7 & 8 are used as secondary inputs with common.

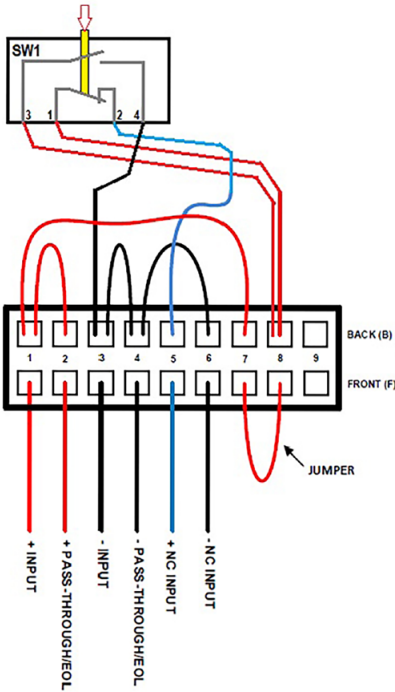

STANDARD SPDT SWITCH WIRING

Figure A

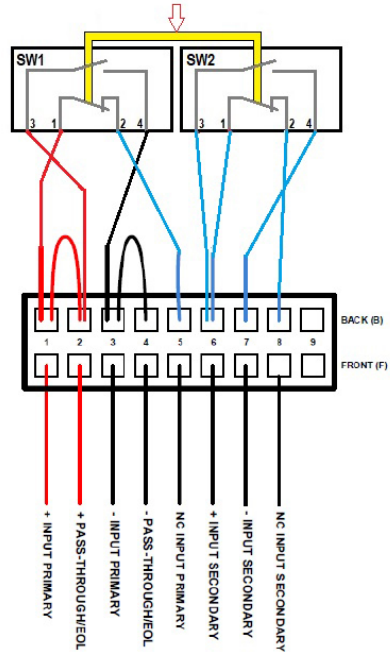

STANDARD DPDT SWITCH WIRING

Figure B

Installation and Maintenance Instructions

Optional EOL, Diode & Series Resistor Module Install & Wiring, SPDT & DPDT devices:

⚠ WARNING

For the SPDT & DPDT models with optional field installed EOL or Series Resistor Module(s), please note the following applicable requirements for these specific models:

- **When using with a fire alarm control panel, the panel is to be power limited to 5A maximum. An LED, EOL, or series resistor may require a compatible control panel.**

The separately supplied EOL & Series Resistor (as well as Diode) modules are installed via snap-fit clips into two possible locations on the rear mounting plate for wiring ease & replaceability:

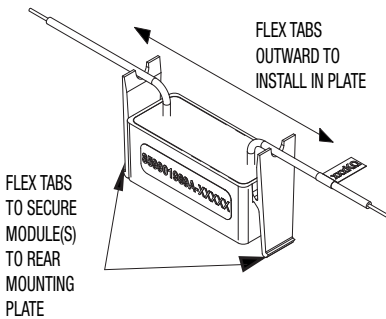

Figure 12

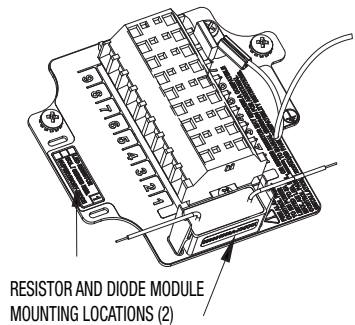
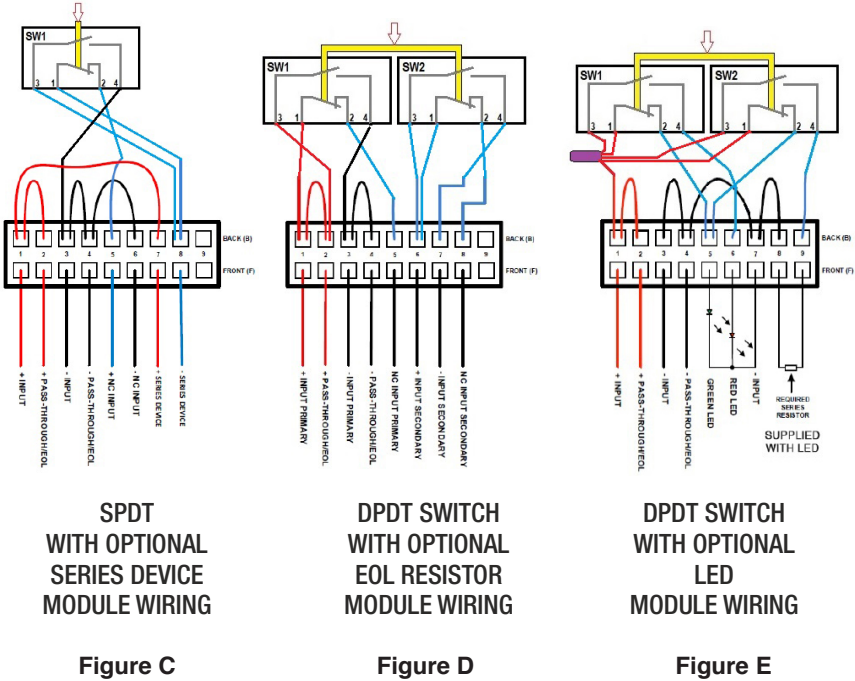

Figure 13

Installation and Maintenance Instructions

Optional Bi-Color LED Module Wiring

For the SPDT & DPDT models with an optional factory wired, voltage dependent (6, 12, 24, 48 VDC) Bi-Color LED module and series resistor module added to the front housing (having green illumination in the standby “Normal” mode and red within the “Alarm” state), please note the following applicable requirements for these specific models:



⚠ WARNING

- Insure that the additional activation current draw of 13mA of the red alarm state LED function will not interfere with the alarm notification panel. If it does, the hookup of the red LED lead must be disconnected from the terminations block. **Failure to observe this warning may lead to property damage, serious injury or death.**
- ***When using with a fire alarm control panel, the panel is to be power limited to 5A maximum. An LED, EOL, or series resistor may require a compatible control panel.***

Installation and Maintenance Instructions

Fire Alarm Control Panel (FACP)

For Federal Signal Call Points stations (Model CP-PB and CP-BG), a compatibility check must be made of the station(s) when installed to a FACP.



Failure to conduct a compatibility check per the guidelines listed below may lead to property damage, serious injury or death.

Models with no LED

Standby Mode Impedance: Equal to the EOL Resistor value (no EOL Resistor equals infinite Ω). Alarm Mode Impedance: Equal to the Series Resistor value (no Series Resistor equals 0Ω).

Models with Factory Provided LED

Standby Mode Impedance: Equal to the EOL Resistor value (no EOL Resistor equals infinite Ω). Alarm Mode Impedance: Variable. Based on EOL selected and models rated voltage. Refer to Table 1 below. Models with a factory provided LED will contain the following installed LED series resistors: 6V model: 470Ω , 12V model: $1K\Omega$, 24V: $1.8K\Omega$, and 48V model: $3.3K\Omega$. Table 1 takes this additional impedance into account.

		ALARM MODE NOMINAL IMPEDANCE FOR A CALLPOINT WITH LED MODULE			
		6V	12V	24V	48V
EOL RESISTOR	470	235.00	319.73		
	1000	319.73	500.00	642.86	
	2200	387.27	687.50	990.00	1320.00
	3300	411.41	767.44	1164.71	1650.00
	4700	427.27	824.56	1301.54	1938.75
	5000	429.62	833.33	1323.53	1987.95
	5600	433.61	848.48	1362.16	2076.40
	10000	448.90	909.09	1525.42	2481.20
	12000	452.29	923.08	1565.22	2588.24
	15000	455.72	937.50	1607.14	2704.92
	22000	460.17	956.52	1663.87	2869.57
	33000	463.40	970.59	1706.90	3000.00
	47000	465.35	979.17	1733.61	3083.50

Table 1

Installation and Maintenance Instructions

Electrical Specifications:

MAXIMUM INPUT VOLTAGE:

6, 12, 24, or 48 VDC when LEDs are present; if no LEDs are present 48 VDC MAX.

MAXIMUM INPUT CURRENT:

5A / 1A*

**1A with FS approved diode installed (ref. table 2 pages 34-35 for diode part number)*

VOLTAGE	EOL/SERIES RESISTOR VALUE RANGE
6 VDC	470 - 47K Ω
12 VDC	470 - 47K Ω
24 VDC	1K - 47K Ω
48 VDC	2.2K - 47K Ω

WARNING

Before connecting to power, the user must confirm the external voltage source and internal EOL/Series resistor values are in accordance as shown above. The resistance of the resistor modules are marked on the resistor module enclosures. If the EOL/series resistor value chosen is outside the range above, the hazardous area safety protection of the Ex potted module is compromised. The maximum power dissipation on the resistor is 1W. **Failure to observe this warning may lead to property damage, serious injury or death.**

MAXIMUM GROUND WIRE:

12 AWG / 2.05mm²

Installation and Maintenance Instructions

Manual Test & Reset Operation of the Station

The CP-PB and the CP-BG stations have separate activation techniques for both placing the internal switch into the alarm state, and also resetting the stations to normal after the alarm state. Follow the instructions accordingly to your station type.

CP-PB Stations:

Activation Test

For the manual push button stations, activation is accomplished by a front force directly inwards towards the station against the black pushbutton, locking the pushbutton in an alarm state. Upon doing so, the activation indicator with reset keyway on the front face located directly below the push button will rotate approximately 60° clockwise positioning itself in the direction of the “ALARM” state away from the “NORMAL” standby state. Insure that the proper switch activation has occurred and that the associated control panel is in alarm mode for the station.

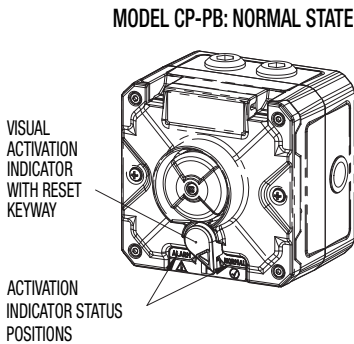

Figure 14

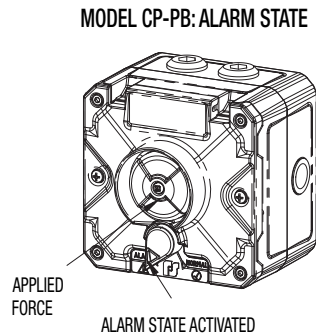

Figure 15

Reset Test

For the manual pushbutton stations, resetting is accomplished by rotating the activation indicator approximately 60° counter-clockwise by use of a reset keyway that is mated to the activation indicator. Upon rotating counter-clockwise the push button knob along with the internal switch, will be released from their activated ALARM states and return back to their NORMAL standby positions as noted on the station’s front faceplate. Insure that the proper switch de-activation has occurred and that the associated control panel returns back to normal standby mode for the station.

Installation and Maintenance Instructions

CP-BG Stations:

Activation Test

For the manual break glass stations, activation may be accomplished by either of two means:

1. Applying a front force directly inwards towards the station against the glass panel, which is noted with "BREAK GLASS PRESS HERE" along with a corresponding target dot to apply the force to break the glass panel. A polyester label is attached on the glass panel to protect the user from glass particles when the panel is broken. Once broken, the unit must have the panel replaced for resetting it.

MODEL CP-BG: NORMAL STATE

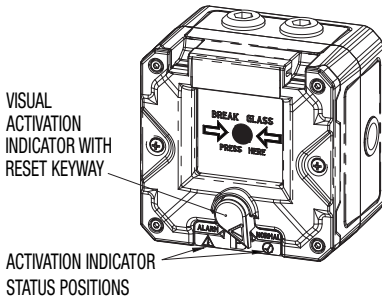

Figure 16

MODEL CP-BG: ALARM STATE

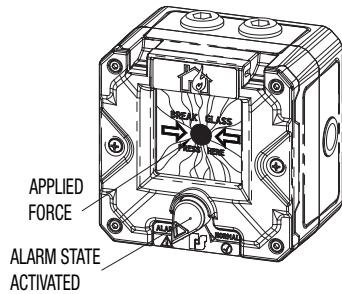

Figure 17

2. Using the reset keyway (factory attached on non- CP-BG-x-x-x-xxx-xx-2 stations) mated to the faceplate's activation indicator, rotate the indicator approximately 60° clockwise until the indicator notes "ALARM" state. The glass panel will physically be displaced upwards during this action, and the internal switch will be activated without breaking the glass panel. This provides a means of testing the station without breaking the glass panel and replacing it.

Note: On CP-BG-x-x-x-xxx-xx-2 (EN54-11) models the keyway is not factory attached, it is supplied separately within the packaging. Per EN54-11 standards and regulations it is only to be used separately as a discrete standalone keyway to reset an EN54-11 Call Point station.

MODEL CP-BG:
ALARM STATE

RESET KEYWAY ACTIVATED

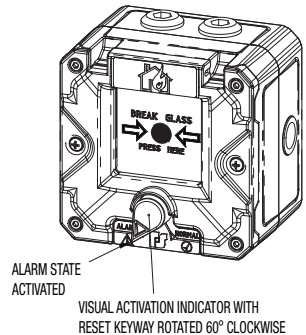

Figure 18

Installation and Maintenance Instructions

Upon doing either, the activation indicator with or without the reset keyway will be rotated approximately 60° clockwise in the direction of the “ALARM” state away from the “NORMAL” standby state triggering the internal switch. Insure that the proper switch activation has occurred and that the associated control panel is in alarm mode for the station.

Reset Test

For the manual break glass stations, resetting is accomplished by either of two methods (following the previously mentioned two methods of activating the stations):

1. To replace the broken glass panel, follow the directives on page 25. Once replaced, the internal mechanism should be back to its NORMAL standby position as noted on the station’s front faceplate. Insure that the proper switch de-activation has occurred and that the associated control panel returns back to normal standby mode for the station.
2. To reset the glass panel in the NORMAL state (the glass panel is unbroken) rotate the activation indicator approximately 60° counter-clockwise by use of a reset keyway that is mated to the activation indicator. Upon rotating counter-clockwise the glass panel will move slightly downwards, and the internal switch will be released from its activated ALARM state, returning the station back to its NORMAL standby position as noted on the station’s front faceplate. Insure that the proper switch de-activation has occurred and that the associated control panel returns back to normal standby mode for the station.

NOTE: if the reset keyway (which is NOT factory installed on EN54-11 stations) remains installed on the activation indicator, the action remains the same, with a larger indicator showing the station’s status. BUT the possibility of access to resetting the station is evident to those reasonably knowledgeable of its operation that are nearby, which may result in false signals being sent to the indicating control panel. Reference page 27 for instructions to remove the factory installed keyway for use only by authorized personnel. Failure to observe this warning may lead to property damage, serious injury or death.

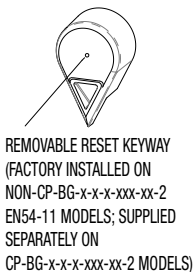

Figure 19

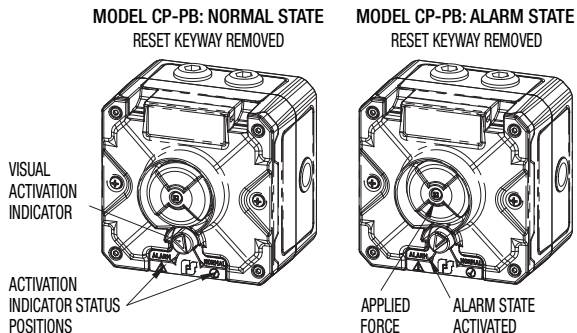

Figure 20

Figure 21

Installation and Maintenance Instructions

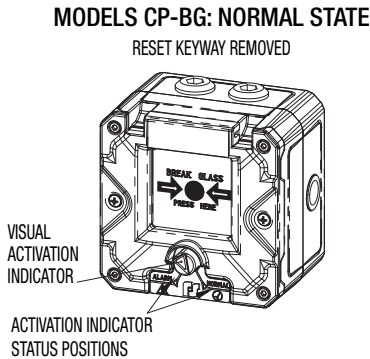

Figure 22

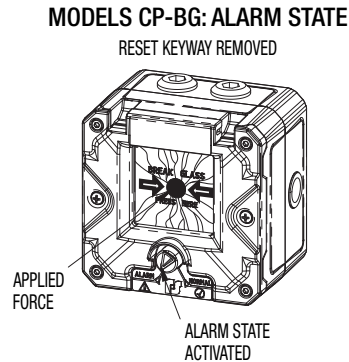

Figure 23

Safety Messages to Maintenance Personnel

Listed below are some important safety instructions and precautions you should follow with regards to all instructions within this manual:

- Read and understand all instructions before operating this system.
- If you acquired a significant quantity of units, then it is recommended that spares are also made available.
- Any maintenance to the Call Points station must be done with power turned off.
- Any maintenance to the Call Points station must be performed by a trained electrician who is thoroughly familiar with all applicable national and local codes in the country of use.
- Never alter the unit in any manner. Safety of the unit may be affected if additional openings or other alterations are made to the internal components or housing.
- The nameplate, which may contain cautionary or other information of importance to maintenance personnel, should NOT be obscured in any way. Ensure that the nameplate remains readable.
- After performing any maintenance, test the Call Points station to ensure that it is operating properly.

Failure to follow all safety precautions and instructions may result in property damage, serious injury, or death.

Installation and Maintenance Instructions

Maintaining/Modifying the Call Point Station

During the working life of the station, it should require little or no maintenance. The non-metallic front and rear glass reinforced polyester (GRP) housings will resist attack by most acids, alkalis, and chemicals and is as resistant to concentrated acids and alkalis as most metal products. The front faceplates are of the same material with an acrylic color overcoat. However, if abnormal or unusual environment conditions occur due to plant damage or accident, etc., visual inspection of the Call Point station is recommended. Replacement front faceplates are available if a need arises.

Cleaning the Enclosure

The housing/faceplate enclosure should be cleaned periodically with a damp cloth to maintain legibility of all labels, icons, and optional LED output. While cleaning, if it is noticed that any part of the station is damaged, it must be replaced to maintain the functional integrity of the device. Reference the service/accessory parts section of this manual to do so.

Replacing the Break Glass Panel (CP-BG units)

To replace a broken glass panel on the station, the steps to be followed are:

1. Safety gloves are required when accessing the internal front chamber that has a broken glass panel in order to prevent wounds.
2. Carefully remove the front faceplate to access the front chamber (ref. page 10). Caution should be taken as sharp glass pieces may be evident which may result in wounds.
3. Remove and carefully discard the remaining panel pieces from the front chamber and any that may have fallen outside of the chamber/station.

MODEL CP-BG: ALARM STATE

FRONT CHAMBER ACCESS – BREAK GLASS REMOVAL

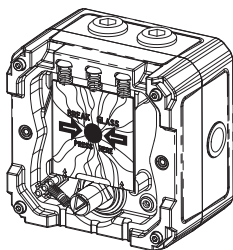

Figure 24

Installation and Maintenance Instructions

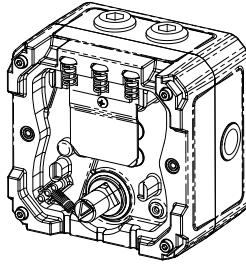

Figure 25

4. Position the replacement glass panel at an angle as shown in the following illustration with its top edge placed against the three return bias springs. Along the bottom edge, place a thumb at the dual black triangles on either side. Applying pressure to the panel with the two thumbs, push upwards towards the three springs enough to wedge the glass panel next to the activation indicator's cam surface and into the two corner bosses holding the panel in place. The panel should now be constrained so that it does not push itself outwards.

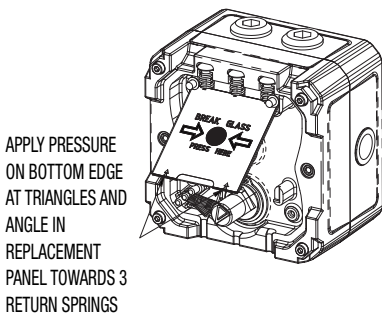

Figure 26

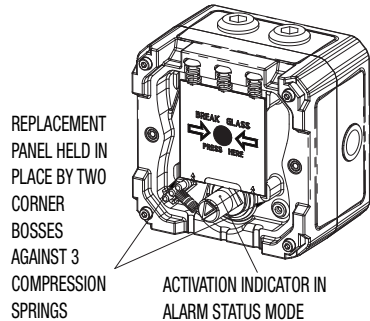

Figure 27

5. Reattach the front faceplate (ref. Opening / Closing of the Call Point for Internal Access).
6. Note that the activation indicator is in ALARM status mode. With the reset keyway attached, rotate the indicator about 60° counter-clockwise if it is desired to return to NORMAL status mode.

Installation and Maintenance Instructions

MODEL CP-BG: NORMAL STATE

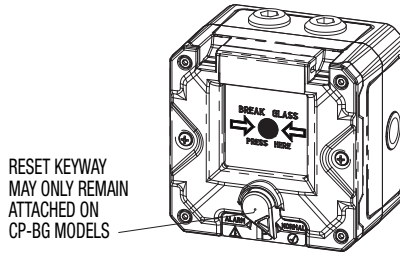

Figure 28

Installing/Serviceing the Reset Keyway

The reset keyway is provided factory attached on the CP-PB & CP-BG stations. On the CP-BG-x-x-x-xxx-xx-2 (E54-11 approved) stations it is provided separately to only be used as a discrete standalone key. On these models, the key should not be permanently installed for EN-54-11 installations and shall be used only for the test purposes. Its purpose is twofold:

1. Provide a means of resetting all devices after an activated ALARM status, by a 60° counter-clockwise rotation of the activation indicator.
2. Provide a means of ALARM activation testing of the CP-BG stations without breaking the glass panel

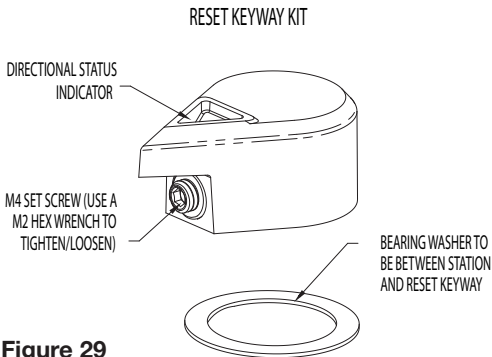

Figure 29

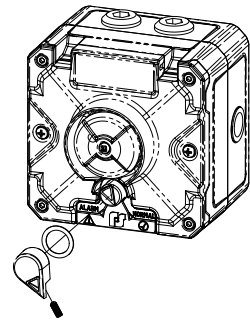

Figure 30

Removal/attachment of the reset keyway is easily done by use of a M2 hex wrench mated to the M4 set screw below the triangular directional status indicator. The set screw need not be fully removed from the keyway, only unloosen partially enough to lift the keyway along with the bearing washer from the unit's status indicator.

Installation and Maintenance Instructions

Installing/Serviceing the Optional Cover Flap

An optional clear polycarbonate cover flap is provided either factory attached on the CP-PB & CP-BG stations or as a field installable kit. The cover flap may also be ordered with a clear instructional label attached (ex: "IN CASE OF FIRE LIFT COVER BREAK GLASS", "IN CASE OF FIRE LIFT COVER PUSH BUTTON", "TO ACTIVATE LIFT COVER BREAK GLASS", & "TO ACTIVATE LIFT COVER PUSH BUTTON"). "IN CASE OF FIRE LIFT COVER BREAK GLASS" marking must be present on EN54-11 certified models. To remove, or remove/reattach a cover flap:

1. Remove the front faceplate per directions found earlier in this manual under "Call Point Front Chamber Access". Place the two stainless steel pivot pins of the cover flap in order to rest within the slot found on the backside of the faceplate, and rotate the cover 180° to snap the cover flap onto the front face.
2. Re-attach the faceplate (ref. Opening / Closing of the Call Point for Internal Access), then open the cover to reattach the push button and the reset keyway if they are provided with the station.
3. Insure access to the activation push button or glass panel is easily accomplished by lifting the cover flap upwards.

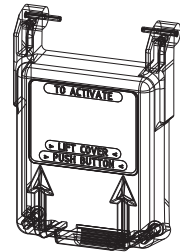

Figure 31

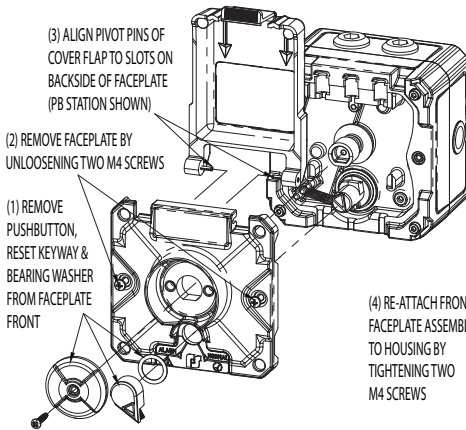

Figure 32

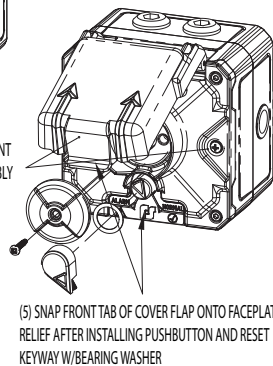

Figure 33

Installation and Maintenance Instructions

Servicing the LED Module

NOTE: The bi-color LED service kit option is only provided for factory LED installed stations in either 6, 12, 24, or 48 VDC applications noted as such on their model # : CP-BG-x-x-x-xxx-XX-x or CP-PB-x-x-x-xxx-XX-xx where XX = 06, 12, 24, or 48 VDC on stations where the LED is present. If XX = 00, no LED is present within the unit.

⚠ WARNING

Replacement service kits are NOT to be installed on stations with XX = 00 within their model number. Failure to observe this warning may lead to property damage, serious injury or death.

In the event that the LED is not lighting in either normal (green) or alarm (red) state within a LED station, it should be replaced along with its series resistor with the proper kit dependent upon its applicable voltage (ref. table 2, pages 34-35 for the available kits). The kit will consist of the LED module, and its corresponding series resistor along with two wire ties.

Tools needed (after internal access):

- Wire cutter
- #1 Philips screwdriver

1. Insure that the power is off and the station is in NORMAL mode.
2. Open the station so that the front housings internal side is shown (*ref. Opening / Closing of the Call Point for Internal Access*), along with the internal side of the rear housing. Remove the three screws holding the switch shroud in place to gain easier access to the LED module:
3. Remove the mounting screw holding the LED module in place (and set it aside as it will be needed for installing the replacement), and clip and remove the wire ties bundling the three LED wires to the switch wires.

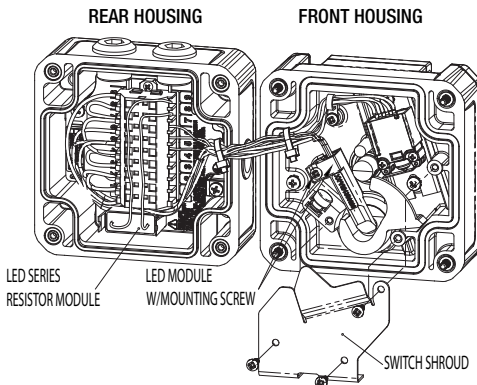

Figure 34

Installation and Maintenance Instructions

4. Carefully remove the LED module by lifting it from its recessed relief in the front housing.
5. Remove the three LED 22 AWG leads from the cage clamp wiring block:
Green wire @ terminal #5
Red wire @ terminal #6
Black wire @ terminal #7
6. Remove the corresponding series resistor module (snap tabs) whose leads are attached to terminals #8 and #9 of the block.

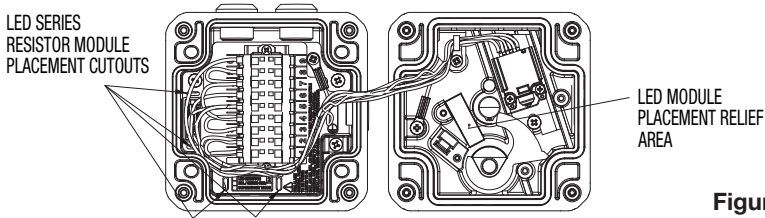

Figure 35

7. In reverse order begin the replacements process:
 - a. Replace the series resistor with the one provided within the kit, running the two leads to terminals #8 and #9. Snap the resistor module in place where the previous one was located.
 - b. Attach the three wires from the replacement LED module to the wiring block:
Green wire @ terminal #5
Red wire @ terminal #6
Black wire @ terminal #7
 - c. Notice the rectangular relief (fig. 35) within the inside housing wall where the previous LED module was seated. Place the replacement LED module within the same relief and tighten in place with the same screw previously taken out.
 - d. While still open, repeatedly (min. 10 times) actuate the station to insure that the LED module is properly seated properly in place and does not interfere with the actuation cylinder's rotational movement about it. If not, unscrew and reseat the module in its reliefs, screw in place and try again
 - e. After confirming the station actuates properly use the two wire ties provided within the kit to bundle and tie the switch wires to the LED wires in locations were the previous wire ties were. Clip off the excess of the wire tie so that it cannot interfere with the switch's actuation.
8. Re-attach the front housing to the rear housing (ref. Opening / Closing of the Call Point for Internal Access)
9. Insure the station is full working (both LEDs work in their respective status: Red = alarm state; Green = Normal State) order after power has been re-applied.

Installation and Maintenance Instructions

Installing/Serviceing the Optional Break Glass Hammer Bar

NOTE: *the break hammer bar kit cannot be used with stations that already have a side stainless steel duty label already attached to the station.*

The optional break glass hammer bar kit is side mounted on the rear housing of the station as a factory or field installed option. The kit contains all the parts necessary if replacement parts are required for existing damaged or missing parts of the break glass hammer bar option.

Assembly with two mounting screws

The hammer bar can be pulled directly out from its retaining bracket for access to the two mounting holes that are for the attachment of the two supplied #4 screws. Carefully screw the bracket onto the rear housing. **DO NOT OVERTIGHTEN AS THIS MAY DAMAGE THE THREAD ENGAGEMENT TO THE REAR HOUSING.**

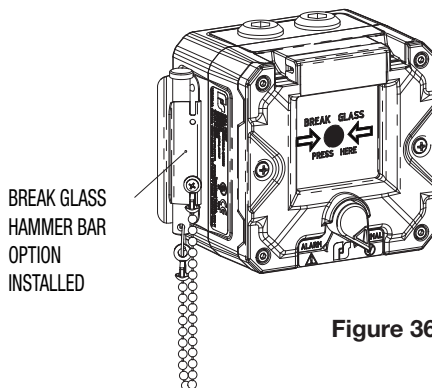

Figure 36

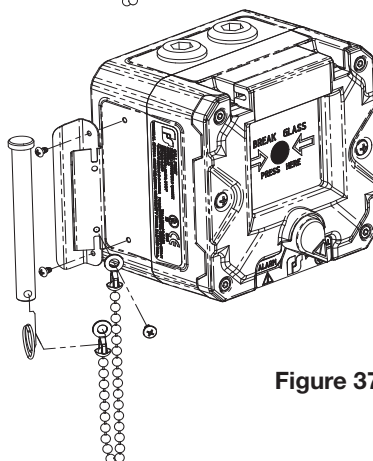

Figure 37

Installing/Serviceing the Optional Stainless Steel Faceplate Labels

Note: *the stainless steel faceplate labels are only to be used on non - EN54-11 stations. Applying one of these labels over the factory installed EN54-11 flaming building label will void its certification.*

These labels are provided separately as a service/accessory part {ref Tables on pp 34-35). Available black text on the labels are “FIRE”, “EVAC”, “GAS ALARM” or “BIOHAZARD ALARM”. The labels have a peel off paper liner exposing a pressure sensitive adhesive backing. Initial placement is critical as the adhesive is aggressive once it touches the station’s faceplate designated label area. Be sure that the application area is free from any dirt, smudges or oil prior to application.

Installation and Maintenance Instructions

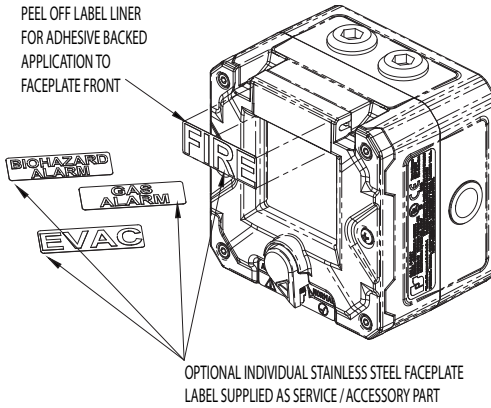

Figure 38

Installing/Servicing the Optional Stainless Steel Custom Duty Plate

Note: the stainless steel Duty Plate kit cannot be used with BG (break glass) stations that have the Hammer Bar option already installed.

These plates are provided separately as a custom order service/accessory part (ref to Tables on pp 34-35), having the end user provide desired text/artwork for their specific application. The duty plates have a peel off paper liner exposing a pressure sensitive adhesive backing. Initial placement is critical as the adhesive is aggressive once it touches the station's faceplate designated label area. Be sure that the application area is free from any dirt, smudges or oil prior to application. Two screws are also provided so that the plate is securely held in place during the station's life usage. Consult the factory for the lead time regarding the fabrication of custom duty plates along with minimum order quantity.

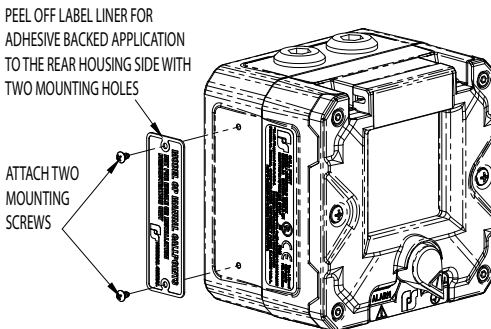

Figure 39

Installation and Maintenance Instructions

Lubricating the Threaded Joints

A silicone based, non-hardening, chemically compatible grease may be applied if required only on the rear housing's three threaded inlet ports.

Note: When using a silicone based grease, use caution in not applying it to the housing gasket or other parts located on the front housing assembly. Failure to do so may compromise the sealing integrity of the device.

Ordering Accessory/Service Parts

Field installed optional accessories and service parts are listed in Table 2. Due to certification, certain component parts are not available for field replacement. Stations with an excessive type of damage must be either replaced entirely or returned to Federal Signal for service.

To order, call Federal Signal Customer Support at 708-534-4756 with the requested part number(s).

Getting Technical Support and Service

The Federal Signal factory provides technical assistance with any problems that cannot be handled locally. Any units returned to Federal Signal for service, inspection, or repair must be accompanied by a Return Material Authorization (RMA). Obtain a RMA from a local Distributor or Manufacturer's Representative. Please provide a brief explanation of the service requested, or the nature of the malfunction.

For technical support and service, visit:

<https://www.fedsig.com/technical-support>

<https://www.fedsig.com/service-centers>

For ordering of additional parts/kits: +1 708-534-4756

Installation and Maintenance Instructions

Call Points Field Installed Service/Accessory Kits

Part Description	Federal Signal Part #	Use
Break Glass Panel, 5-Pack	K859902275A	CP-BG stations
Cover Flap	K859901982A	CP-BG and CP-PB stations
" " w/Label (IN CASE OF FIRE / BREAK GLASS)	K859901982A-01	CP-BG stations
" " w/Label (TO ACTIVATE / BREAK GLASS)	" -02	" " "
" " w/Label (IN CASE OF FIRE /PUSH BUTTON)	" -03	CP-PB stations
" " w/Label (TO ACTIVATE /PUSH BUTTON)	" -04	" " "
Break Glass Hammer Bar w/chain	K859902546A	CP-BG stations
Potted Resistor Module, 470Ω	K859901989A-0470	EOL/Series Resistor; also used with 6V LED option
" " " 1KΩ	" -1000	" " "; also used with 12V LED option
" " " 1.8KΩ	" -1800	" " "; also used with 24V LED option
" " " 2.2KΩ	" -2200	" " "
" " " 2.4KΩ	" -2400	" " "
" " " 3.3KΩ	" -3300	" " "; also used with 48V LED option
" " " 3.6KΩ	" -3600	" " "
" " " 4.7KΩ	" -4700	" " "
" " " 5.6KΩ	" -5600	" " "
" " " 10KΩ	" -10000	" " "
" " " 12KΩ	" -12000	" " "
" " " 15KΩ	" -15000	" " "
" " " 22KΩ	" -22000	" " "
" " " 33KΩ	" -33000	" " "
" " " 47KΩ	" -47000	" " "

Table 2

Installation and Maintenance Instructions

Call Points Field Installed Service/Accessory Kits- cont.

Part Description	Federal Signal Part #	Use
Potted Diode Module, 5A	K859901990A	5A Supervisory Diode Module
Reset Keyways, 5-Pack	K859902467A	CP-BG and CP-PB stations
6 VDC LED Replacement Module Kit (LED + ser. resistor modules)	K859902472A-06	CP-BG and CP-PB LED stations
12 VDC " " " " " " " "	" -12	" " " " "
24 VDC " " " " " " " "	" -24	" " " " "
48 VDC " " " " " " " "	" -48	" " " " "
Break Glass Faceplate, Red	K859902471A-BGRD	CP-BG stations
" " " Yellow	" -BGYL	" " " (Non EN54-11)
" " " Blue	" -BGBL	" " " (Non EN54-11)
" " " Green	" -BGGR	" " " (Non EN54-11)
" " " Black	" -BGBK	" " " (Non EN54-11)
Push Button Faceplate, Red	K859902471A-PBRD	CP-PB stations
" " " Yellow	" -PBYL	" " " "
" " " Blue	" -PBBL	" " " "
" " " Green	" -PBGR	" " " "
" " " Black	" -PB BK	" " " "
Faceplate Labels (6) Sheet, White (FIRE,EVAC,.....)	K71400935A-01	CP-BG & CP-PB red, blue, green & black stations, (Non EN54-11)
" " " " Black (FIRE,EVAC,.....)	" -02	" " " yellow stations
Faceplate Label EN54-11	K71400701A	CP-BG-x-x-x-xxx-xx-2 EN54-11 stations
Faceplate Label, Stainless Steel, FIRE	K71400976A-01	CP-BG and CP-PB stations, (Non EN54-11)
" " " " EVAC	" -02	" " " " (Non EN54-11)
" " " " BIOHAZARD ALARM	" -03	" " " " (Non EN54-11)
" " " " GAS ALARM	" -04	" " " " (Non EN54-11)
Actuation Label, White	K71400699A-01	CP-BG & CP-PB red, blue, green & black stations
" " Black	" -02	" " " yellow stations
Duty Label Stainless Steel with Custom Artwork/Text	K859902480A	Cannot be mounted with hammer bar option. Consult factory for lead time.

Table 2

The Federal Signal factory provides technical assistance with any problems that cannot be handled locally. Any units returned to Federal Signal for service, inspection, or repair must be accompanied by a Return Material Authorization (RMA). Obtain a RMA from a local Distributor or Manufacturer's Representative. Please provide a brief explanation of the service requested, or the nature of the malfunction.

Technical Support Tel:
1-800-755-7621 | +1 708-587-3587

Email: signalsupport@fedsig.com

Customer Support: +1 708-534-4756



Signaling Devices

2645 Federal Signal Drive
University Park, IL 60484-3167
Tel: 708-534-4756
Tech Support Tel: 708-587-3587
Email: signalsupport@fedsig.com
www.fedsig.com