

2562514A REV. A 1009

Safety Message to Installers and Service Personnel of Warning Light Equipment

⚠ WARNING

People's lives depend on your proper installation and servicing of Federal Signal products. It is important to read and follow all instructions shipped with this product and the original product. In addition, listed below are some other important safety instructions and precautions you should follow:

- To properly install this warning light, you must have a good understanding of automotive electrical procedures and systems, along with proficiency in the installation and use of safety warning equipment.
- When drilling into a vehicle structure, be sure that both sides of the surface are clear of anything that could be damaged.
- Always refer to the vehicle service manuals when installing equipment on a vehicle.
- DO NOT install equipment or route wiring or cord in the deployment path of an airbag.
- Follow DOT regulations when placing lights for stop, turn, tail, or marker functions.
- If a seat is temporarily removed, verify with the vehicle manufacturer if the seat needs to be recalibrated for proper airbag deployment.
- You should frequently inspect the light to ensure that it is operating properly and securely attached.
- This product contains high intensity LED devices. To prevent permanent eye damage, DO NOT stare into the light beam at close range.
- File this instruction sheet in a safe place and refer to it when maintaining and/or reinstalling the product.

Failure to follow all safety precautions and instructions may result in property damage, serious injury, or death.

Product Overview

The Federal Signal Model 607124-05DEU is a four-inch-round LED light module that is a sealed, low current device for reverse light use. A nominal 12 Vdc or 24 Vdc circuit is required to power this light.

Unpacking the Kit

After unpacking the kit, inspect it for damage that may have occurred in transit. If it has been damaged, file a claim immediately with the carrier, stating the extent of damage. Carefully check all envelopes, shipping labels, and tags before removing or destroying them.

Installing the Kit

Read all instructions and plan all wiring and cable routing before performing any installation. The vehicle wiring harness must have a mating Deutsch connector with matching wiring placement as described in Table 1.

⚠ WARNING

SEAT REMOVAL PRECAUTION

If a vehicle seat is temporarily removed, verify with the vehicle manufacturer if the seat needs to be recalibrated for proper airbag deployment.

Failure to follow this warning may cause serious injury or death.

⚠ WARNING

AIRBAG DEPLOYMENT

Do not install equipment or route wiring in the deployment path of an airbag.

Failure to observe this warning will reduce the effectiveness of the airbag, or potentially dislodge the equipment, causing serious injury or death.

NOTICE

DRILLING PRECAUTIONS

Before drilling holes, check the area into which you are drilling to be sure you do not damage vehicle components while drilling. All drilled holes should be deburred and all sharp edges should be smoothed. All wiring routings going through drilled holes should be protected by a grommet or convolute/split loom tubing.

1. Determine the mounting location for the light and control switch (installer-supplied). Follow all DOT regulations for the proper location of vehicle lighting and number of lights.
2. Connect the adapter cable to the vehicle wiring harness (Figure 1 on page 3). See Table 1 for an explanation of the adapter cable colors, and for their functions and locations on the Deutsch connector.

Table 1: Cable colors and functions

Wire Color	Circuit Number and Connector	Marking on Lamp Housing	Function: Backup	Deutsch Connector Pin Locator
White	1	GND	Negative Ground	2
Red	3	STOP/TURN	Reverse Positive	1

3. Connect the watertight connector of the adapter cable to the LED module. If the grease in the socket has been depleted, use silicone dielectric grease to lubricate the connector gasket.
4. If a mounting hole is unavailable for the light at the selected location, install the Federal Signal Model No. 601320 (round) or No. 610310 (oval) bracket kit. Position the rubber mounting grommet into the opening for the light with the lettering on the grommet upright.

- Orient the LED module with the lettering upright and push it into the gasket until seated. Apply a firm steady pressure to the top and bottom alternately.

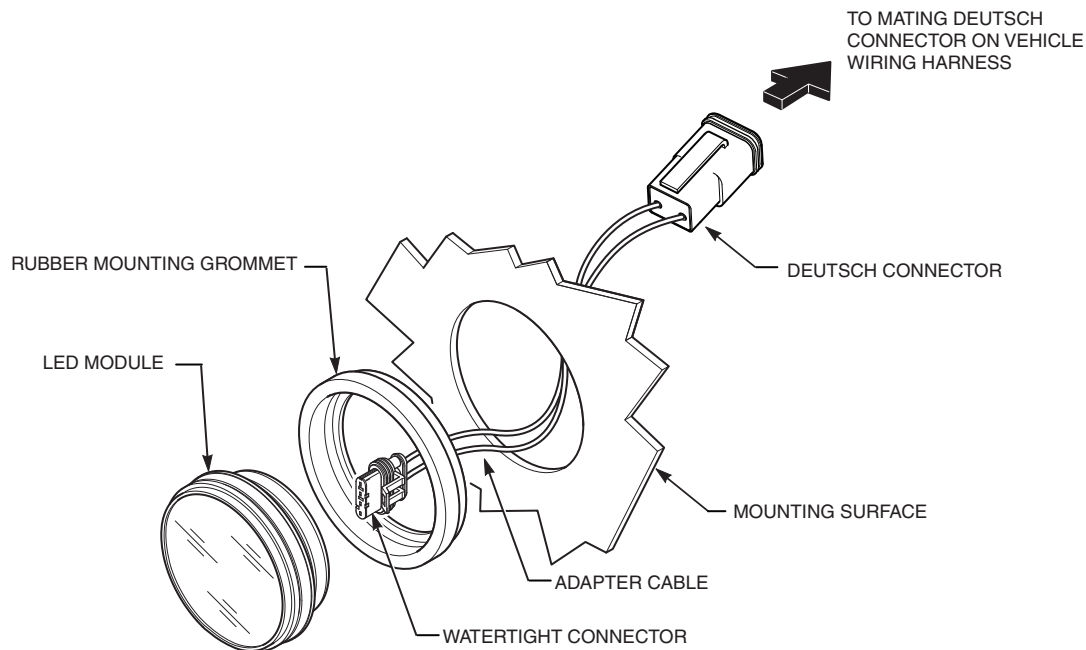

290A6304

Figure 1: Connection between LED module and vehicle wiring harness

Testing the Installation

⚠ WARNING

LIGHT HAZARD

To be an effective warning device, an emergency warning system produces bright light that can be hazardous to your eyesight when viewed at a close range. Do not stare directly into the lights at a close range or permanent damage to your eyesight may occur.

⚠ WARNING

SOUND HAZARD

All effective sirens and horns produce loud sounds (120 dB) that may cause permanent hearing loss. Always minimize your exposure to siren sound and wear hearing protection. Do not sound the siren or horn indoors or in enclosed areas where you and others will be exposed to the sound.

After installing the light, test it to ensure that it is operating properly. Also test all vehicle functions, including horn operation, vehicle safety functions, and vehicle lighting systems to ensure proper operation. Ensure that the installation has not affected the vehicle operation or changed any vehicle safety functions or circuits.

Do not test the sound and light system of the vehicle while driving. Operating the vehicle warning systems may pose a hazard to the operator and other drivers if the systems do not function as expected. Test the vehicle only in a controlled environment.

After testing is complete, provide a copy of these instructions to the instructional staff and all operating personnel.

Technical Support and Service

For technical support and service, please contact:

Service Department
Federal Signal Corporation
Phone: 1-800-433-9132
Fax: 1-800-343-9706
Email: empSERVICEinfo@fedSIG.com

Returning a Product to Federal Signal

Before returning a product to Federal Signal, call 800-264-3578, 800-433-9132, or 800-824-0254 to obtain a Returned Merchandise Authorization number (RMA number). To expedite the process please be prepared with the following information:

- Your Federal Signal customer or account number.
- The purchase order number under which the items were purchased.
- The shipping method.
- The model or part number of the product being returned.
- The quantity of products being returned.
- Drop ship information as needed.
- Any estimate required.

When you receive your RMA Number:

- Write the RMA number on the outside of the box of returned items.
- Reference the RMA number on your paperwork inside of the box.
- Write the RMA number down, so that you can easily check on status of the returned equipment.

Send all material with the issued RMA Number to:

Federal Signal Corporation
2645 Federal Signal Drive
University Park, IL 60484-3176
Attn: Service Department
RMA: # _____



2645 Federal Signal Drive, University Park, IL 60484-3167
Tel.: (800) 264-3578 • Fax: (800) 682-8022
www.fedSIG.com