

INSTALLATION INSTRUCTIONS
FOR
MODEL 416106 STROBE POWER SUPPLY

SAFETY MESSAGE TO INSTALLERS

⚠ WARNING

People's lives depend on your safe installation of our products. It is important to read, understand and follow all instructions shipped with the products. In addition, listed below are some other important safety instructions and precautions you should follow:

- **To properly install this unit: you must have a good understanding of automotive electrical procedures and systems, along with proficiency in the installation and use of safety warning equipment.**
- **When drilling into a vehicle structure, be sure that both sides of the surface are clear of anything that could be damaged.**
- **A light system is a high current device. In order for it to function properly, a separate ground connection must be made. If practical, it should be connected to the negative battery terminal. At a minimum, it may be attached to a solid metal body or chassis part that will provide an effective ground path as long as the light system is to be used.**
- **Do not drill any holes in the power supply housing.**
- **Locate light control so the VEHICLE and CONTROL can be operated safely under all driving conditions.**
- **You should frequently inspect the light system to ensure that it is operating properly and that it is securely attached to the vehicle.**
- **File these instructions in a safe place and refer to them when maintaining and/or reinstalling the product.**

Failure to follow all safety precautions and instructions may result in property damage, serious injury, or death to you or others.

⚠ WARNING

This power supply is designed to power various strobe heads designed by Federal Signal. Consult local codes and regulations to determine if the power supply/strobe head combination complies.

I. GENERAL.

The Federal Model 416106 Silver series strobe/LED power supply is designed to operate on 12 volts DC (13.6 or nominal). It is designed to power six remote Federal strobe heads and to drive two LED loads. The flashing patterns provide at least 75 alternating strobe flashes per minute with a combined flash energy of up to 8 joules (10 watts @ 75 FPM). Each LED driver is capable of providing 4 amps.

This power supply can produce eight flashing patterns. Flash patterns may be selected by means of a momentary pushbutton control. These selections are stored internally in any one of three operating modes. A head cut-off feature is included to disable two strobe heads. The unit may operate in low power mode to reduce output power (light intensity).

II. SPECIFICATIONS.

Input Voltage	12Vdc (13.6 nominal).
Input Current	7.45 amperes @ 13.6vdc
Fuse	10 amperes (automotive type).
Flash Pattern	Refer to table 1.

Dimensions:	
Length	11.15" (283 mm)
Width	2.86" (73 mm)
Height	3.58" (91 mm)

Net Weight	1.75 lbs. (0.80 kg)
Shipping Weight	2.25 lbs. (1.02 kg)

III. INSTALLATION.

CAUTION

The power supply housing is NOT waterproof. It must be mounted in a location, which is sheltered from falling rain, snow, standing water, etc. Also, it must be installed in an adequately ventilated area. Never install near heater ducts.

Do not mount the power supply unit under the vehicle's hood.

When selecting a mounting location for the power supply unit, it is necessary to keep in mind that the cables are available in a limited number of lengths. Plan all wiring and cable routing before performing any installation.

A. Mechanical.

1. Use the power supply as a template and scribe four drill-positioning marks at the selected mounting location.

Flash Pattern	Joules/flash	Flashes/min
Quad	4.0/1.9/1.9/1.9	75
Action	4.0/4.0	75
Random	4.0/4.0	up to 165
Triple	4.0/2.7/2.7	75
Fast Quad	4.0/1.9/1.9/1.9	85
Penta	3.4/1.9/1.9/1.9/1.9	75
Quad/ Action	4.0/1.9/1.9/1.9 4.0/4.0	75 75
Fast Action	2.45/2.45/2.45	112

Table 1.

CAUTION

Before drilling holes in ANY part of a vehicle, be sure that both sides of the mounting surface are clear of parts that could be damaged; such as brake lines, fuel lines, electrical wiring or other vital parts.

⚠ WARNING

DO NOT drill holes in ANY part of the power supply chassis or cover. Damage to the unit, serious injury or death to you or others may result.

2. Drill four mounting holes at the position marks.
3. Secure the power supply to the mounting surface.
4. Install the strobe units as described in the instructions packed with the units.

B. *Flashing Patterns.*

Before proceeding with electrical connections, it is important to understand the flashing configurations available with the unit. Outlets 1 & 3 are designed to flashing simultaneously or “parallel”. Outlets 2 & 4 also form a parallel set. The remaining two outlets, 5 & 6, form

Flash Pattern	Strobe Sequence
Null	
Quad	1, 3 & 6 - 2, 4 & 5
Action	1 & 3, 5, 2 & 4, 6
Random	Pseudo-Random
Triple	1, 3 & 6 - 2, 4 & 5
Fast Quad	1, 3 & 6 - 2, 4 & 5
Penta	1, 3 & 6 - 2, 4 & 5
Quad/ Action	2 times (1, 3 & 6 - 2, 4 & 5) 2 times (1 & 3, 5, 2 & 4, 6)
Fast Action	1 & 3, 5, 2 & 4, 6

Table 2.

an alternating pair of flashing strobe heads. The LED flasher outputs A and B are integrated to track the flashing patterns of strobe output 1 and 2 respectfully. Refer to table 2.

1. Mode input.

Refer to table 3. The power supply has three operating modes. Each mode will maintain the flashing pattern assigned during programming. A priority level has been given to each of three mode inputs as shown. Mode two will override mode one and mode three will override all other mode inputs.

Applying +12Vdc to the user-supplied 14AWG red wire and to the appropriate 22AWG wire activates the flashing.

2. Head Cut-Off.

Refer to table 3. When activated, strobe heads connected to outlets 5 and 6 are disabled. Strobe heads connected to outlets 1 thru 4 remain flashing. Front or rear cutoff is determined by the location of strobe heads connected to outlets 5 and 6.

To activate head cut-off, remove the +12Vdc supply from the 22AWG blue wire.

3. Low Power.

Refer to table 3. The low-power mode reduces flash intensity and current requirement by more than 50 percent.

To activate the low power mode, apply +12Vdc to the 22AWG green wire.

4. Program.

Refer to table 3. Each operating mode can be programmed with a unique flash pattern.

To advance to the next pattern, apply +12Vdc to the 22AWG yellow wire for at least five seconds. Before the next pattern can be selected, the +12Vdc must be removed for at least five seconds then reapplied.

Description	Function	Color
Mode 1	Priority Low	Violet
Mode 2	Priority Medium	Orange
Mode 3	Priority High	Brown
Head Cut-off	Control Input	Blue
Low Power	Control Input	Green
Program	Control Input	Yellow
LED Channel A	Output Driver	Gray
LED Channel B	Output Driver	White

Table 3.

C. Electrical Connections.

WARNING

Failure to observe this WARNING may result in fire, burns or blindness.

If shorted to vehicle frame, high current conductors can cause hazardous sparks resulting in electrical fires or molten metal.

DO NOT connect this system to vehicle battery until ALL other electrical connections are made and mounting of all components is complete.

Verify that no short circuits exist, before making connection to the vehicle battery.

1. Disconnect vehicle battery. Ensure that power is disconnected from all vehicle lighting control systems.
2. Ensure that the power supply chassis is grounded to the vehicle chassis. If necessary, connect a wire from the power supply chassis (mounting screw) to a known good vehicle chassis ground.

IMPORTANT

See figure 1 while completing the electrical connections.

3. Connect the user-supplied black wire to the power supply's BLK/- terminal. Note that the quick-connect terminal for the black wire is wider than the terminal for the red wire. Dress the wire neatly, allowing for a drain loop and maintenance. Connect it to a known good vehicle chassis ground.

NOTE

Powering multiple devices with a common control lead may cause one or more units to briefly remain functional after signal power is removed. For example, due to the high input filter capacitance, a strobe supply can briefly supply the current required to operate a low current device such as a Cuda TriOptic™. If necessary, use a relay to isolate devices with large filter capacitors. See figure 2 for the schematic; all components/wires are user-supplied.

4. Connect the control wire harness to the power supply. Connect all wires, except the gray wire and the white wire, to a 12 volt power source (switch, relay, or vehicle lighting controller) capable of supplying 1-ampere. If desired, selected control wires can be connected directly to the 12 volt power source, or can remain not connected.

5. Be aware, the mode inputs are prioritized; therefore direct power connection to higher mode input(s) will disable lower mode(s) of operation.

6. Connect the gray and white wires to the cathode of LED channels A and B respectively. The power supply functions as a low-side switch for each LED channel and may handle a maximum load of 4-amperes. Exceeding

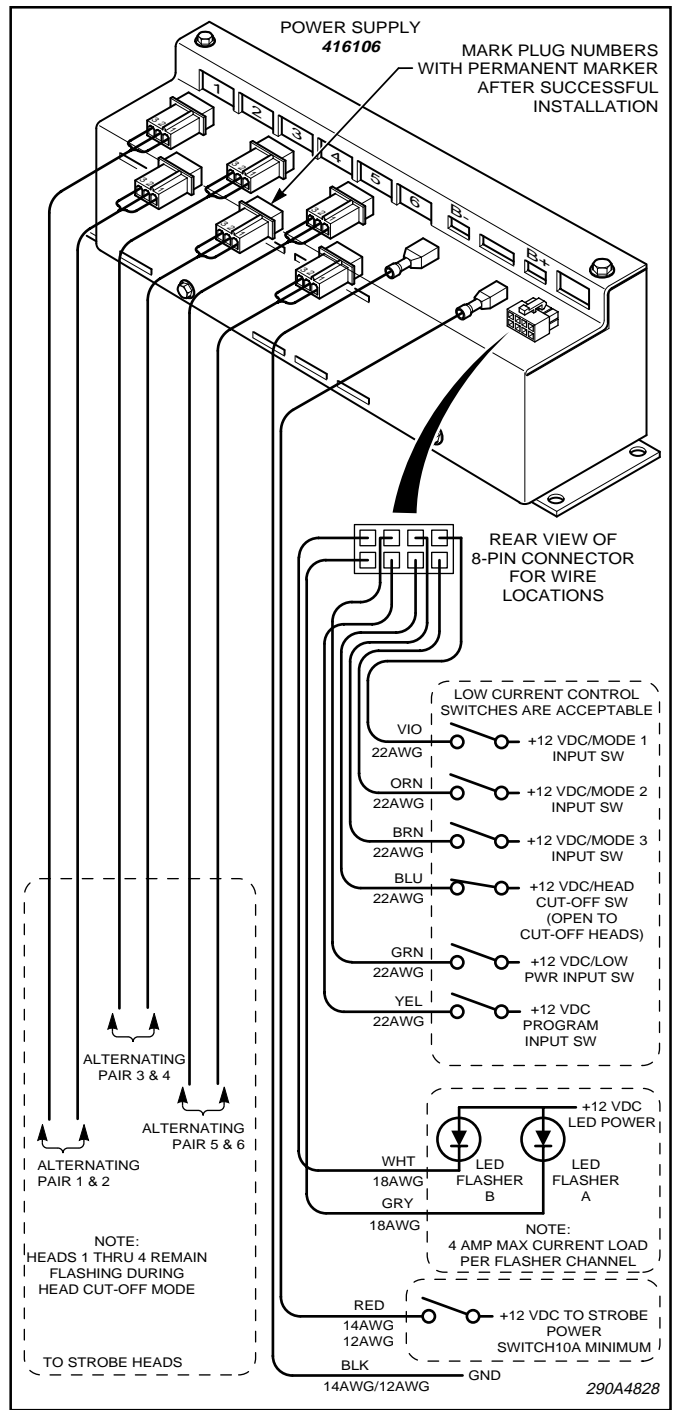

Figure 1.

this limit may cause permanent damage to the LED driver circuit.

7. See figure 1 and proceed as follows:

- a. Choose the pair of heads that should remain flashing when cutoff is activated. Connect their cables to outlets 1 thru 4.
- b. Connect the cables of the other pair of heads to outlets 5 and 6.
- c. Refer to the instructions supplied with the strobe head units, or cable kit, for additional wiring instructions. Route the cables to the strobe tube units. Allow for a drain loop and maintenance.

8. Connect the user-supplied red wire to the power supply's RED/+ terminal. Note that the quick-connect terminal for the red wire is narrower than the terminal for the black wire. Dress the wire neatly, allowing for a drain loop and maintenance. Connect it to a 12 volt power source (switch, relay, or vehicle lighting controller) capable of supplying a minimum of 10-amperes.

9. Check all connections and wiring. Ensure that there are no short circuits and that all wires are protected from any sharp edges. Reconnect the vehicle battery. Test for proper operation of the strobe system. Check all the flashing functions. If necessary, adjust the positions of the strobe head plugs connected to the power supply. When satisfied with the flashing patterns, use a permanent marker and mark the strobe plugs with the appropriate outlet numbers.

IV. OPERATION.

SAFETY MESSAGE TO OPERATORS

⚠ WARNING

Peoples' lives depend on your safe use of our products. Listed below are some important safety instructions and precautions you should follow:

- **Do not attempt to activate or deactivate light control while driving in a hazardous situation.**
- **Although your warning system is operating properly, it may not be completely effective. People may not see or heed your warning signal. You must recognize this fact and continue driving cautiously.**
- **Also, situations may occur which obstruct your warning signal when natural or man-made objects are between your vehicle and others, such as: raising your hood or trunk lid. If these situations occur, be especially careful.**
- **At the start of your shift, you should ensure that the lights are securely attached and all units are operating properly.**
- **If a selected function does not perform properly or if any of the lamps remain illuminated when the control is off, disconnect the power connector from the control unit and contact the nearest service center.**

Failure to follow these safety precautions may result in property damage, serious injury, or death to you, to passengers, or to others.

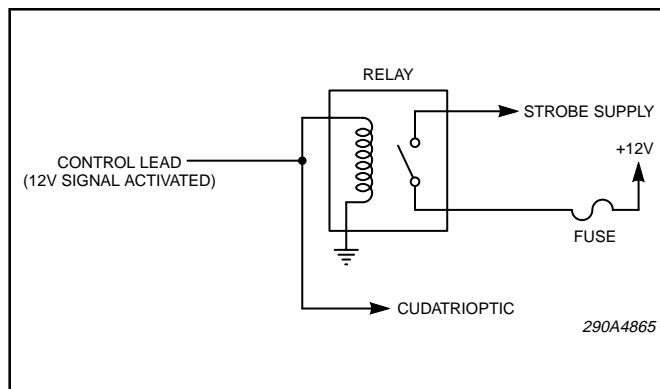

Figure 2.

V. SERVICE.

⚠ WARNING

High voltages are present in a strobe light system. Wait at least five (5) minutes, after shutting off power, before servicing the unit. Failure to do so may result in property damage, serious injury, or death to you and others.

Servicing should be performed by a qualified Federal Signal service center. If the power supply is not working properly, disconnect power and ground to the unit. Next, disconnect the electrical connections to the strobe tubes. Remove the power supply from the vehicle. Send the unit to the nearest authorized service center or to the Federal Signal service department.

Communication and shipments should be addressed to:

Service Department
 Federal Signal Corporation
 2645 Federal Signal Drive
 University Park, IL 60466
 1-800-433-9132
 (In Illinois) 708-534-3400

⚠ WARNING

The fuse MUST be replaced with an exact replacement only.

After servicing is complete, perform a test to ensure the power supply is operating properly.

VI. REPLACEMENT PARTS.

Description	Part No.
Fuse, 10 Ampere	148181A-05
Printed Circuit Board Assy.	2005242A
Power Supply Unit	8575247A
Accessory Kit	8575259A

VII. ACCESSORY KIT CONTENTS LIST.

Qty.	Description	Part No.
1	Terminal, Wide	224A216-04L
1	Terminal, Narrow	224A215-04L
1	Control Harness/Plug	1751232A