

► Model IS-IIP100 Series C

## 100W, Indoor/Outdoor, Audible Sounder



The standalone Informer100 Sounder is a 100-watt, indoor/outdoor audible sounder. The Informer100 can be used as a warning and alerting device for both audible broadcast and visual indication. The audible capabilities include locally stored, high-quality, high-powered tones and pre-recorded voice messages. Visual indicators sold separately can be mounted to the top ½" NPT entry and controlled via relay output. The Informer100 is designed for outdoor and indoor use, especially in loud industrial facilities.

The Informer100 Sounder has an internal 100-watt amplifier/driver to deliver tone warnings and voice messages from Informer100 stored memory. The Informer100 Sounder is a standalone device where external inputs are used to activate audible broadcasts. This is useful if the location requires voice and tone alerts from locally activated inputs without network connectivity. Out-of-the-box, the Informer100 Sounder is pre-programmed with (4) dry contact inputs for local activation. Through a web-interface, users can change the standard configuration to utilize the (4) control inputs to broadcast digital audio files from the included microSD card. The audio microSD card is pre-loaded with 163 standard messages and tones, including tones from the SelecTone UTM Tone Module, and is expandable to hold up to 4,000 messages or 17 hours of audio to meet your application needs.

Standalone Informer100 models are available in 24VDC or 120/240VAC depending on model purchased. Models include a mechanical relay, a DC solid-state relay output, and an AC solid-state relay output for controlling strobes or other devices. The bottom of the speaker has three ¾" NPT openings for access to power, LAN programming port, relay outputs, and activation inputs. All wiring interfaces are accessible via internal connectors. The Informer100 includes a stainless steel mounting bracket to adjust sounder orientation. Optional pole mount brackets are available for small and large diameter poles.

### F E A T U R E S

- 100-watt, High-Powered, Indoor/Outdoor, Audible Sounder
- Available in 24VDC and 120/240VAC
- Out-of-the-box configuration (all modes are maintained and normally open)
  - Tone 1 – NFPA Temporal Coded Slow Whoop
  - Tone 2 – Alternating High-Low
  - Tone 3 – Rapid Siren (Yelp)
  - Tone 4 – Steady Horn (Euro-Toxic)
- Changes to the standard configuration can be made using the Informer web programming interface. Reference the IS-IIP100 manual for instructions
- Sounder rated at 120 dBA @ 10' (130 dBA @ 1m)
- Relay outputs to control visual indicators or other devices
- Four local alarm inputs to activate the unit locally for standalone operation
  - Momentary mode: contact closure plays selected alarm tone file(s) one time
  - Continuous mode: plays selected alarm tone file(s) for duration of the contact closure (Maintained Operation)
- Wall or pole mount options
- Marine rated
- NEMA 4X enclosure
- UL and cUL Listed

# High-Powered, Indoor/Outdoor, Audible Speaker (IS-I-IP100DC and IS-I-IP100AC)

MODEL	VOLTAGE	OPERATING CURRENT	DECIBELS	
			10'	1 M
<b>IS-I-IP100DC</b>	24VDC	5.15 amps	120	130
<b>IS-I-IP100AC</b>	120/240VAC	1.50 amps	120	130

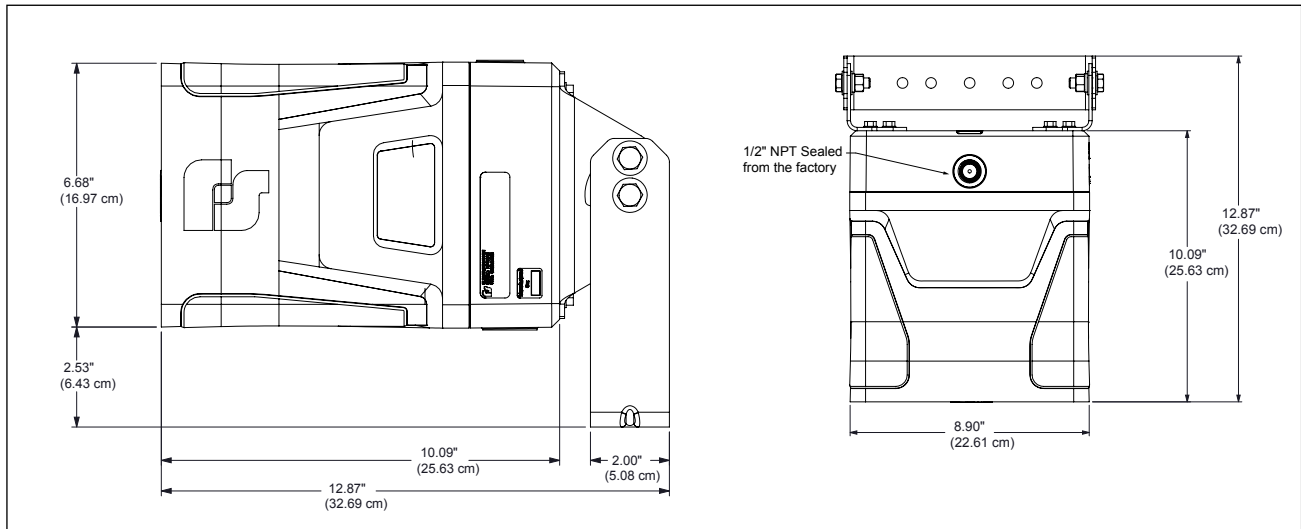

## SPECIFICATIONS

Operating Temperature:	-40°F to +50°F	-40°C to +104°C
Height:	7.0 in	177.8 mm
Width:	9.0 in	228.6 mm
Depth:	10.0 in	254.0 mm
Net Weight:		
<b>IS-I-IP100DC</b>	16.2 lbs	7.35 kg
<b>IS-I-IP100AC</b>	22.0 lbs	9.98 kg
Shipping Weight:		
<b>IS-I-IP100DC</b>	21.0 lbs	9.53 kg
<b>IS-I-IP100AC</b>	24.0 lbs	10.89 kg

## HOW TO ORDER

Description	Part Number
Standalone Informer100, 24VDC, wall mount	<b>IS-I-IP100DC</b>
Standalone Informer100, 120/240 VAC, wall mount	<b>IS-I-IP100AC</b>

## OPTIONAL ACCESSORIES

Description	Part Number
Small pole mount bracket (6-inches or less)	<b>IS-I-IP100-PM</b>
Large pole mount bracket (over 6-inches)	<b>IS-I-IP100-PMW</b>
Omnidirectional bracket	<b>IS-I-IP100-OMNI</b>