

► Models 504WB and 506WB

Vibratone® Bell Assemblies



Vibratone® Bell Assembly Models 504WB and 506WB are completely assembled and include the gong, vibrating AC mechanism, and the gasketed back box. These assemblies feature heavy-duty, industrial grade housings and powder-coat paint treatments for added durability and performance.

Vibratone gongs are tempered to produce superior output and long-lasting durability.

Both models contain internal terminal blocks which simplifies installation. This method also allows for an uninterrupted, single run of wiring.

FEATURES

- Available in 120VAC
- Four-inch or six-inch options
- Four-inch gong produces 98 dBa @ 10' (108 dBa @ 1m)
Six-inch gong produces 100 dBa @ 10' (110 dBa @ 1m)
- Type 3R enclosure
- CSA Certified
- UL and cUL Listed

MODEL	VOLTAGE	OPERATING CURRENT	DECIBELS	
			10'	1M
504WB-120	120VAC	0.08 amps	98	108
506WB-120	120VAC	0.08 amps	100	110

Vibratone® Bell Assemblies (504WB and 506WB)

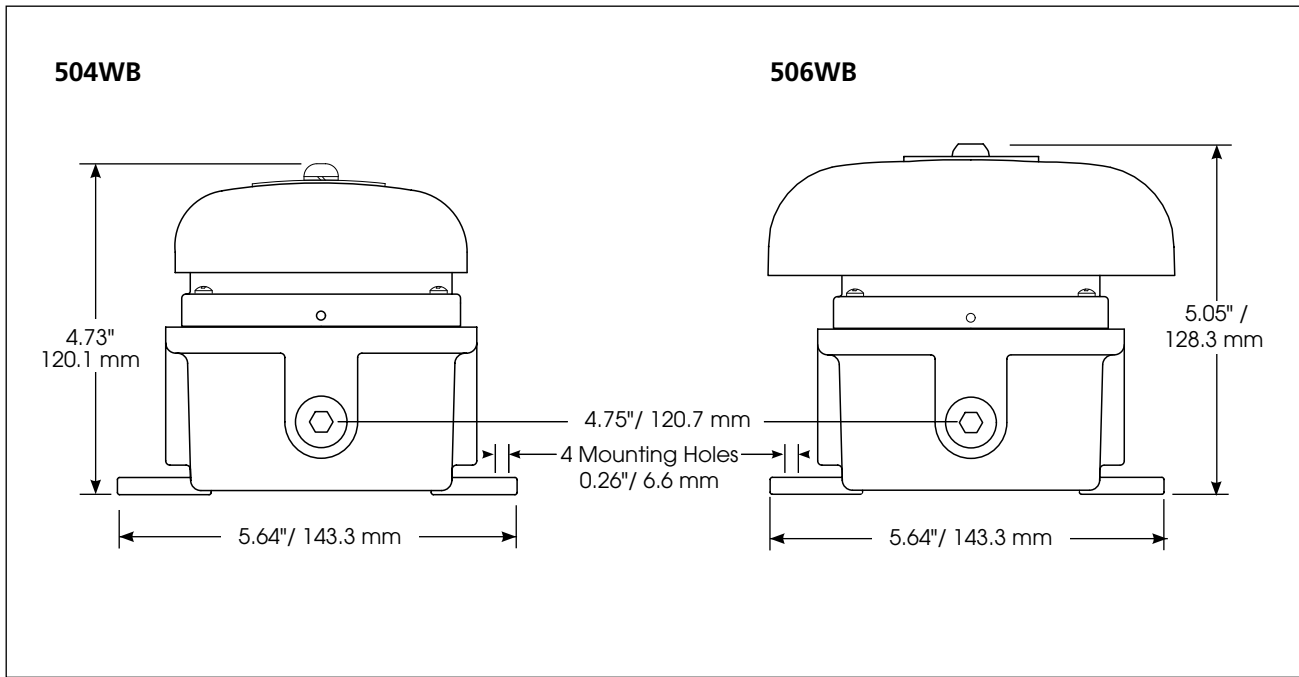

SPECIFICATIONS

Operating Temperature: -31°F to 150°F -35°C to 66°C
 Duty Cycle: 5 minutes ON/5 minutes OFF

Net Weight:
 Model 504 1.05 lbs 0.48 kg
 Model 506 2.5 lbs 1.13 kg

Shipping Weight:
 Model 504 1.65 lbs 0.75 kg
 Model 506 3.0 lbs 1.36 kg

Depth:
 Model 504 4.73" 120.1 mm
 Model 506 5.05" 128.3 mm

Width:
 Model 504 5.64" 143.3 mm
 Model 506 5.64" 143.3 mm

HOW TO ORDER

Specify Model:

504WB-120 – Vibrating bell, 4", 120VAC weatherproof back box

506WB-120 – Vibrating bell, 6", 120VAC weatherproof back box