

► Model 350TR

## Vibratone® Horn with Weatherproof Trim Ring



Model 350TR Vibratone® Horn produces a loud tone by the electro-mechanical vibration of the diaphragm. Its compact size, loud output, and heavy-duty construction makes Model 350TR ideal for industrial and institutional signaling applications. It's popularly used for general alarming, start and dismissal noticing, coded paging and process control in high ambient noise areas.

Model 350TR offers the benefits of quick and simple surface mount installation as each horn is supplied with a gasketed trim ring. Model 350TR is enclosed in a zinc diecast housing and sealed with gray, powder-coat paint.



### F E A T U R E S

- 24 Vac and 120 Vac
- Produces 100 dBa at 10' (110 dBa at 1 m)
- Coded or sustained tones
- Surface or flush mount
- Type 4X and Type 12 enclosure
- UL and cUL Listed

MODEL	VOLTAGE	OPERATING CURRENT	DECIBELS	
			10'	1 M
<b>350TR-024</b>	24 Vac 50/60 Hz	0.90 A	100	110
<b>350TR-120</b>	120 Vac 50/60 Hz	0.22 A	100	110

# Vibratone® Horn with Weatherproof Trim Ring (350TR)

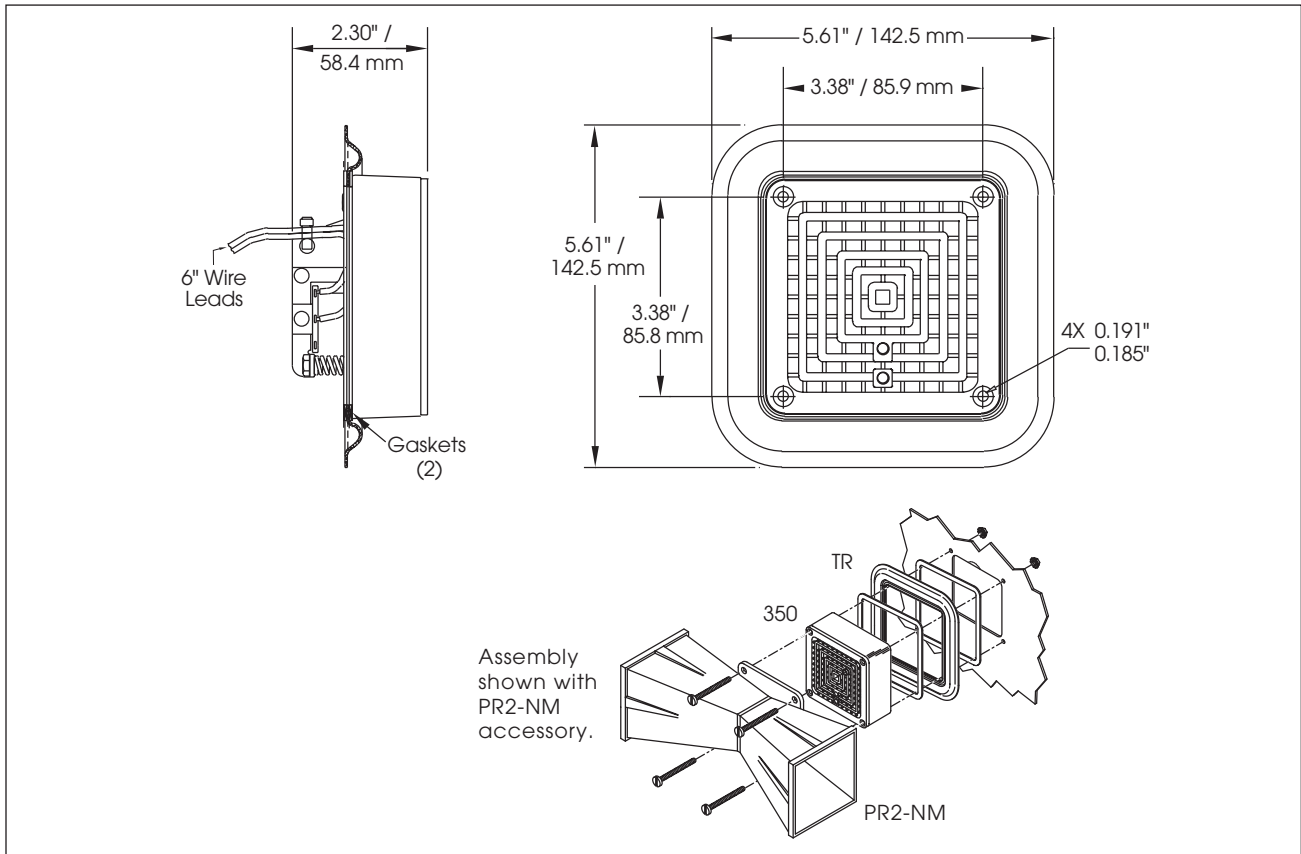

## SPECIFICATIONS

Operating Temperature:	-65° to 150°F (-54° to 66°C)
Duty Cycle:	5 minutes ON/5 minutes OFF
Net Weight:	1.7 lb (0.77 kg)
Shipping Weight:	1.8 lb (0.81 kg)
Height:	5.61 in (142.5 mm)
Width:	5.61 in (142.5 mm)
Depth:	2.30 in (58.4 mm)

## REPLACEMENT PARTS

Description	Part Number
Volume Control Kit	<b>K8435663B</b>
Coil, 120 Vac	<b>KFC1516C</b>

## HOW TO ORDER

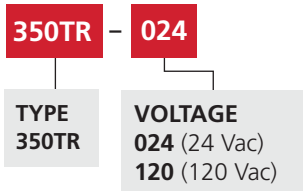

## ACCESSORIES

Description	Part Number
Non-metallic double projector directs sounds to both sides when attached to 350/450E models; ideal for use in hallways; 4" H x 11-1/2" W x 4" D; shipping weight 1 lb (0.45 kg)	<b>PR2-NM</b>

