



Models SSTX3-MV

Explosion-Proof Remotely Selectable Electronic Siren

SSTX3-MV is an explosion-proof electronic siren capable of producing three high-decibel tones from the same unit. The integrated circuitry is contained in a rugged diecast aluminum housing. The unique threaded rear access cover eliminates traditional time-consuming bolting patterns. The access cover is also equipped with a braided cable lanyard securing it to the housing whenever the cover is open for installation or maintenance.

Model SSTX3-MV can be used as a stand-alone, full output, audible warning device in any explosion-proof environment where multiple tones are needed but voice paging is not required.

Typical uses include emergency warning, start and dismissal, general alarm, and evacuation.



FEATURES

- Multi-voltage design – accepts 24 Vdc, 120 Vac or 240 Vac
- Produces three user activated tones – wail, yelp, and horn
- Produces 101-108 dBA at 10' (111-118 dBA at 1 m)
- Cast copper-free aluminum housing, spun aluminum projector
- Indoor/outdoor use
- Type 4X, IP66 enclosure
- UL and cUL Listed for Class I, Division 1, Groups B, C, and D; Class I, Division 2, Group A; Class II, Division 2, Groups F and G; Class III

MODEL	VOLTAGE	OPERATING CURRENT	TONE	DECIBELS	
				10'	1 m
SSTX3-MV	24 Vdc	600 mA	Wail	108	118
	120 Vac	210 mA	Yelp	108	118
	240 Vac	120 mA	Horn	101	111

HAZARDOUS LOCATION RATING: SSTX3-MV

T-CODE AT MAXIMUM AMBIENT TEMPERATURE, °C

Hazardous Location	40°C	66°C
Class I, Division 1, Groups B, C & D	T6	T6
Class I, Division 2, Groups A	T3B	T3
Class II, Division 2, Groups F & G	T6	T6
Class III	T6	T6

Explosion-Proof Remotely Selectable Electronic Siren (SSTX3-MV)

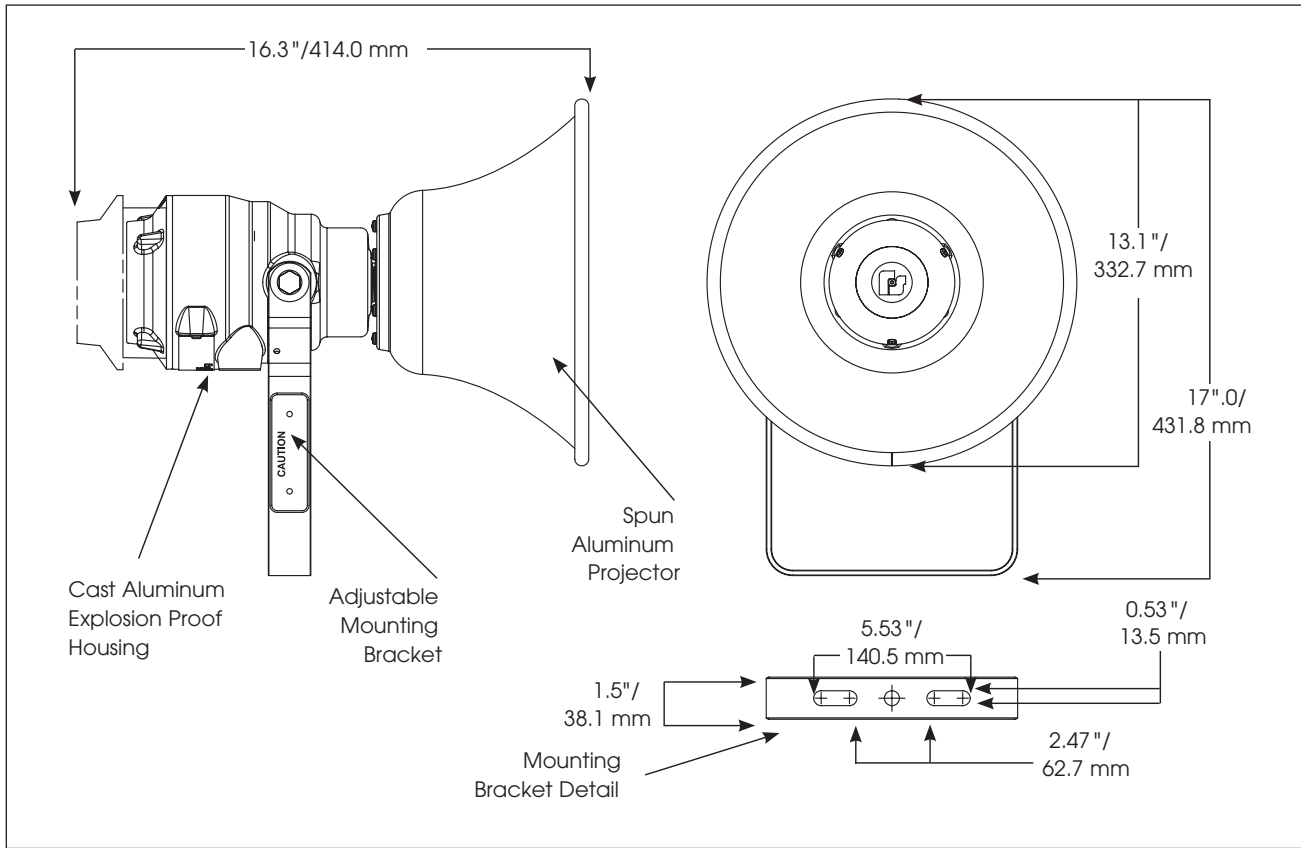

SPECIFICATIONS

Operating Temperature:	-67° to 151°F (-55°C to 66°C)
Net Weight:	15.4 lb (7.0 kg)
Shipping Weight:	22.8 lb (10.3 kg)
Height:	17.0 in (431.8 mm)
Width:	13.1 in (332.7 mm)
Depth:	16.3 in (414.0 mm)

REPLACEMENT PARTS

Description	Part Number
Connector, 4-Position	K140340B
PC Board Assembly	K2005110A
Projector Assembly	K8593100A

HOW TO ORDER

Description	Part Number
Siren, electronic, remotely selectable, explosion-proof, multi-voltage	SSTX3-MV