

► Model LSH

Litestak[®] Piezoelectric Horn



Model LSH

The Litestak[®] LSH Horn is a piezoelectric unit that employs a ceramic element which expands or bends when voltage is applied, generating a single tone. The Model LSH can be used as a stand-alone audible device (with the LSB pipe/surface mount base or LSBS surface mount base), or combined with the Federal Signal Litestak light modules to create a combination audible/visual signal.

The LSH Horn is a modular unit which mounts directly onto the top of any Litestak light or base (sound units must be positioned at the top module of the status indicator). A black speaker grille cover protects the horn. The volume can be adjusted by removing the grille covers and adjusting the volume control below the horn mechanism. All Litestak models should be mounted base down.

Ideal applications for Litestak audible/visual status indicators include assembly lines, conveyor systems, automated lines, instrument panels, workshops, etc.

FEATURES

- Available in 24VDC and 120VAC
- Adjustable volume
- Capable of producing 75-77 dBa @ 10' (85-87 dBa @ 1m)
- Indoor use only
- Type 1 enclosure
- UL Listed and CSA Certified

MODEL	VOLTAGE	OPERATING CURRENT	DECIBELS	
			10'	1M
LSH-024	24VDC	70 mA	75	85
LSH-120	120VAC	40 mA	77	87

Litestak® Piezoelectric Horn (LSH)

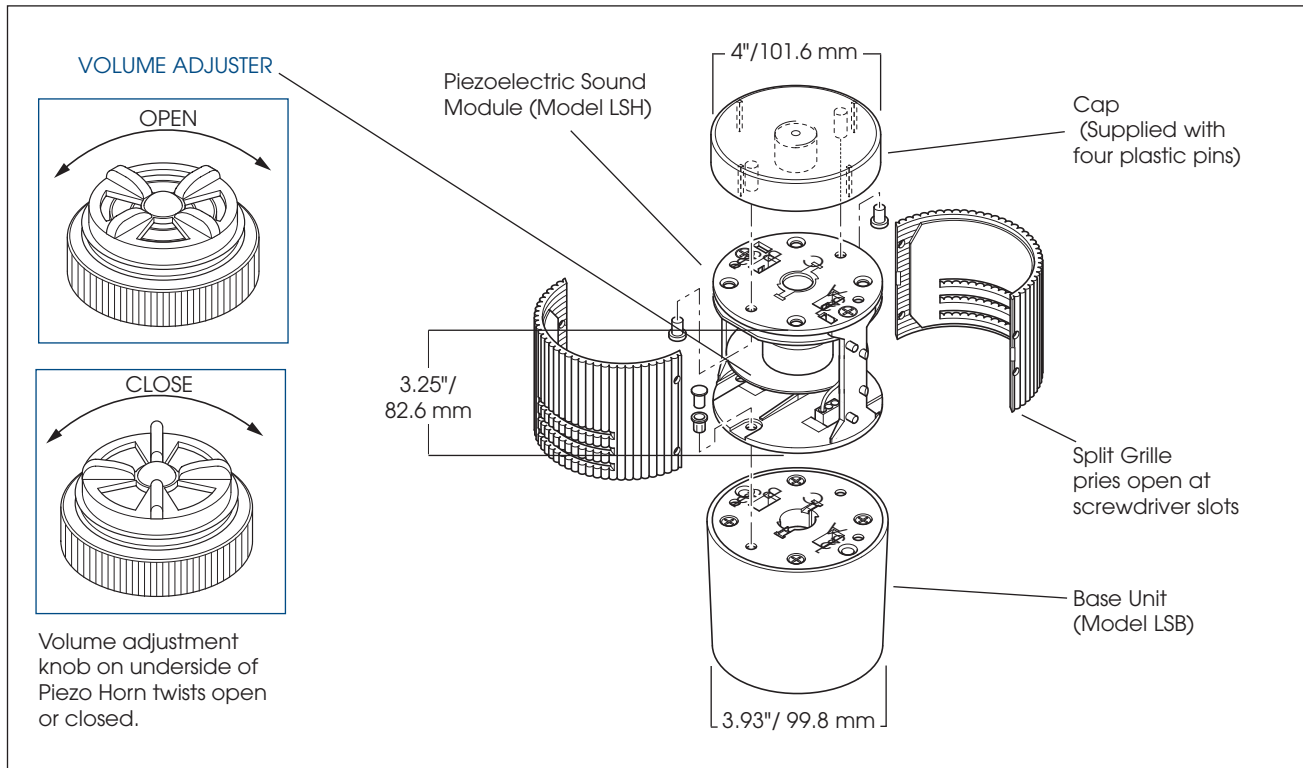

SPECIFICATIONS

Operating Temperature:	32°F to 120°F	0°C to 49°C
Net Weight:	0.45 lbs	0.2 kg
Shipping Weight:	0.65 lbs	0.3 kg
Height:	3.25"	82.6 mm
Diameter:	3.93"	99.8 mm

HOW TO ORDER

LSH	-	024
TYPE		VOLTAGE
LSH		024 (24VDC)
		120 (120VAC)