



► Models 131ST and 131DST

Starfire® Strobe Lights

Federal Signal's Starfire® strobe warning lights are available in single-flash (131ST) and double-flash (131DST) models.

The base of the light is made of corrosion-resistant, anodized aluminum. Each Starfire model comes with a standard 1/2-inch NPT pipe mount. An optional surface mount kit can be ordered.

Because of its convenient size and intense light output, the Starfire strobes can be used for multiple applications.

Excellent for in-plant use, Models 131ST and 131DST warn of hazardous conditions, mark dangerous areas (either permanently or temporarily), and mount on lift trucks, cranes, and other moving devices.



FEATURES

- Available in 12-24 Vdc, 120 Vac, and 240 Vac
- Five lens colors: Amber, Blue, Clear, Green, and Red
- 10,000-hour strobe tube
- Single- or double-flash strobe options
- 1/2-inch NPT pipe mount
- Indoor/outdoor use
- Conformal coated PCB
- Type 3 enclosure (dome up orientation)
- UL and cUL Listed

MODEL	VOLTAGE	OPERATING CURRENT	FLASH RATE / MINUTE	LIGHT OUTPUT		MOUNT ⁴
				PEAK ¹	ECP ²	
131ST-012-024*	12-24 Vdc	2.75-1.25 A	80	2,000,000 cd	1,000 cd	1/2-inch NPT Pipe
131ST-120*	120 Vac 50/60 Hz	0.60 A	80	2,000,000 cd	1,000 cd	1/2-inch NPT Pipe
131ST-240*	240 Vac	0.30 A	80	2,000,000 cd	1,000 cd	1/2-inch NPT Pipe
131DST-012-024*	12-24 Vdc	3.0-1.9 A	80 ³	1,000,000 cd	1,200 cd	1/2-inch NPT Pipe
131DST-120*	120 Vac	0.60 A	80 ³	1,000,000 cd	1,200 cd	1/2-inch NPT Pipe
131DST-240*	240 Vac	0.30 A	80 ³	1,000,000 cd	1,200 cd	1/2-inch NPT Pipe

* Indicates color: (A) Amber, (B) Blue, (C) Clear, (G) Green, or (R) Red

¹ Peak candela is the maximum light intensity generated by a flashing light during its light pulse

² ECP (Effective Candela) is the intensity that would appear to an observer if the light were burning steadily

³ Double Flash

⁴ Surface mount kits available

Starfire® Strobe Lights (131ST and 131DST)

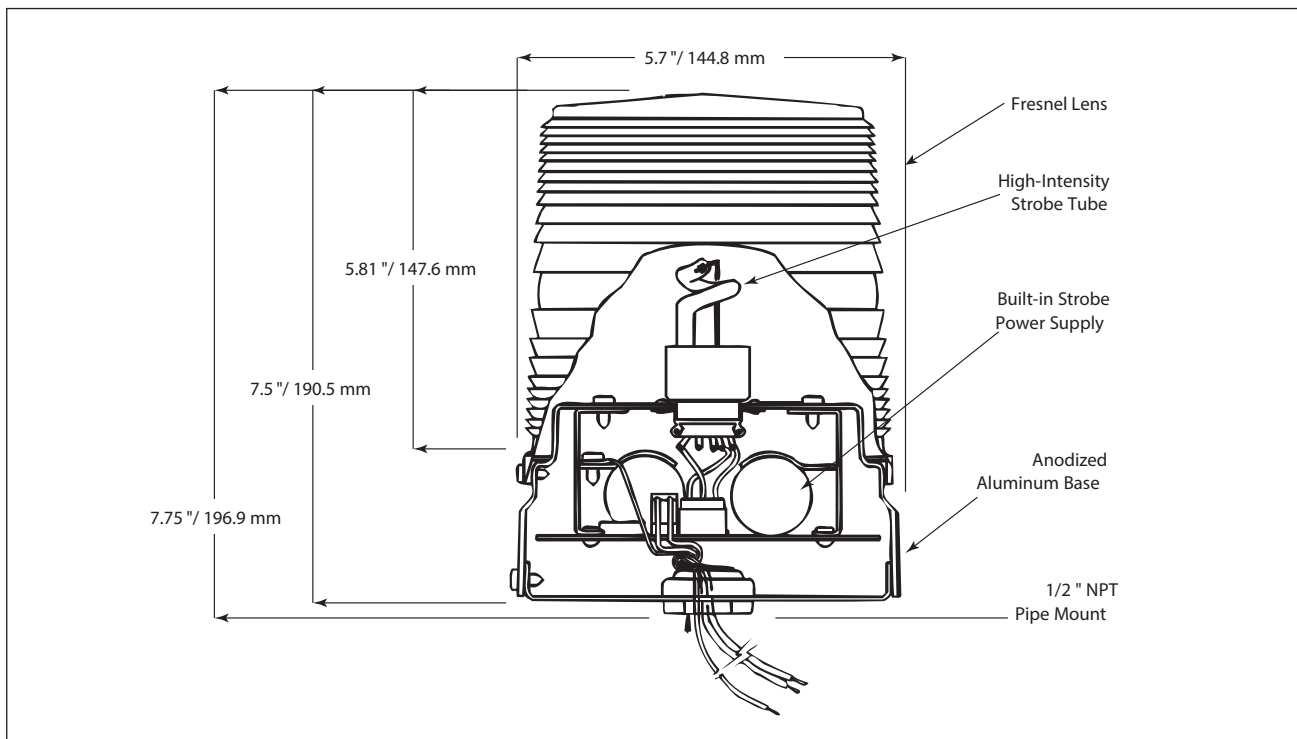

SPECIFICATIONS

Lamp Life:	10,000 Hours
Light Source:	Strobe tube
Operating Temperature:	-31° to 150°F (-35° to 66°C)
Net Weight:	2.0 lb (0.91 kg)
Shipping Weight:	3.4 lb (1.54 kg)
Height:	7.75 in (196.9 mm)
Diameter:	5.7 in (144.8 mm)

ACCESSORIES

Description	Part Number
Corner Bracket	LCMB2*
Wall Bracket	LWMB2*
Surface Mount	K8444A211B
* Type 3R rated	

HOW TO ORDER

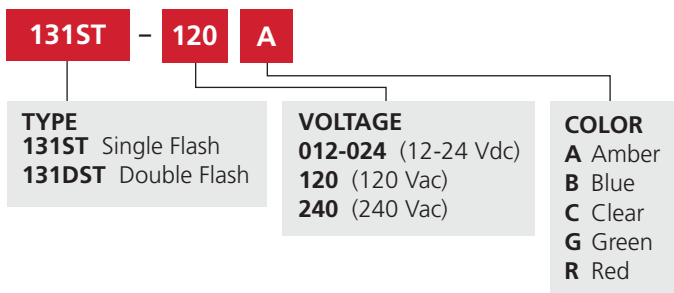

REPLACEMENT PARTS

Description	Part Number
Lens, Amber ¹	K8422B428A-01
Lens, Blue ¹	K8422B428A-02
Lens, Clear ¹	K8422B428A
Lens, Green ¹	K8422B428A-03
Lens, Red ¹	K8422B428A-04
Strobe Tube	K8107178A
Surface Mount Kit	K8444A211B

* Includes 1 dome gasket