

2562402B REV. B1 0517

Safety Message to Installers of Warning Light Equipment

⚠ WARNING

People's lives depend on your safe installation of our products. It is important to read, understand and follow all instructions shipped with the products. In addition, listed below are some other important safety instructions and precautions you should follow:

- To properly install a light assembly, you must have a good understanding of automotive electrical procedures and systems, along with proficiency in the installation and use of safety warning equipment.
- Before drilling into a vehicle structure, be sure that both sides of the surface are clear of anything that could be damaged.
- If a vehicle seat is temporarily removed, verify with the vehicle manufacturer if the seat needs to be recalibrated for proper airbag deployment.
- This product contains high intensity LED devices. To prevent permanent eye damage, DO NOT stare into the light beam at close range.
- You should frequently inspect the light system to ensure that it is operating properly and that it is securely attached to the vehicle.
- Refer to the instructions packed with related products for additional precautions and information.
- File these instructions in a safe place and refer to them when maintaining or reinstalling the product.

Failure to follow all safety precautions and instructions may result in property damage, serious injury, or death.

Mounting Bracket for IMPAXX® and VIPER® EXT

This publication has instructions for using two models of mounting brackets to install the IMPAXX and VIPER EXT lightheads on left and right sides of a vehicle's license plate. The models are the IPX-LPV1 License Plate Mounting Bracket, which fits many vehicles, and the IPX-LPVX1 Extended License Plate Bracket for the rear of the Ford Crown Victoria and other vehicles with a recessed license plate.

Unpacking the Kit

After unpacking the kit, inspect it for damage that may have occurred in transit. If it has been damaged, do not attempt to install or operate it. File a claim immediately with the carrier, stating the extent of damage. Carefully check all envelopes, shipping labels, and tags before removing or destroying them. Ensure that the parts listed in Table 1 are included in the package. If you are missing any parts, contact Customer Support at 1-800-264-3578, 7 a.m. to 5 p.m., Monday through Friday (CT).

Table 1 Kit contents

Qty.	Description	Part Number
1	Bracket, Center OR	8613166
1	Bracket, Center, Extended	8613171
2	Bracket, End, Vertical	8613167
4	Screw, #10, Type B, Pan-Head, TORX, Steel	7011246A-06

NOTE: For electrical installation instructions, refer to the Installation and Maintenance Instructions packed with the IMPAXX or Viper EXT.

Mounting the Light

WARNING **AIRBAG DEPLOYMENT**—Do not install equipment or route wiring in the deployment path of an air bag. Failure to observe this warning will reduce the effectiveness of the air bag, or potentially dislodge the equipment, causing serious injury or death.

IMPORTANT: Plan all cable routing before the installation.

1. Route the wires from the lightheads through the brackets.
2. Mount the lightheads to the end brackets using the hardware supplied with the lightheads. The IPX300 Series mounts with the bezel; the IPX600 Series and the Viper EXT mount without the bezel (Figures 1 and 2). Remove the two #10-32 TORX screws from the back of the IPX600 before mounting the lighthead.

Figure 1 IPX300 and Viper EXT mounted to center bracket

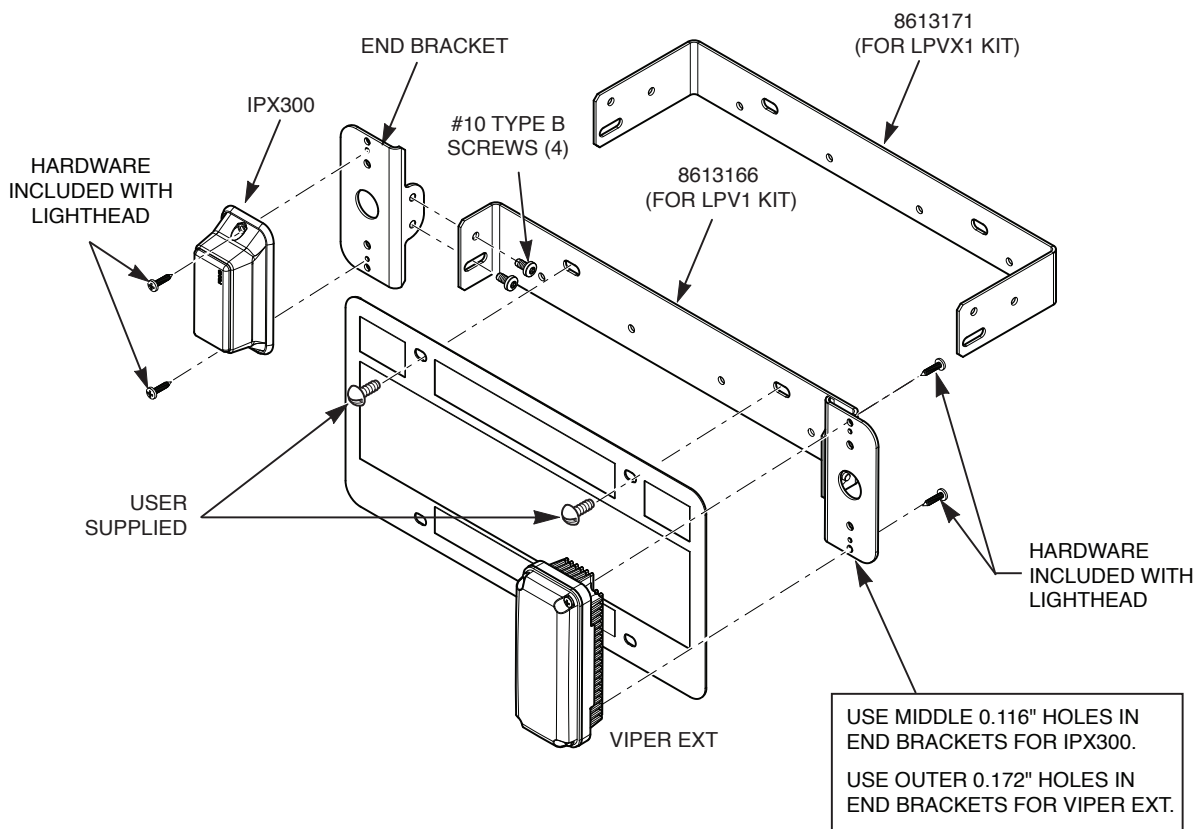

3. Mount the end brackets to the center bracket with the #10 Type B TORX screws. Do not tighten the screws yet.
4. Mount the lighthead\bracket assembly behind the license plate with user-supplied hardware.
5. Adjust the aim of the lightheads, then tighten the screws.

6. Connect the IMPAXX or Viper EXT lights as described in the instructions provided with the lights.
7. Test the warning lights for proper operation.

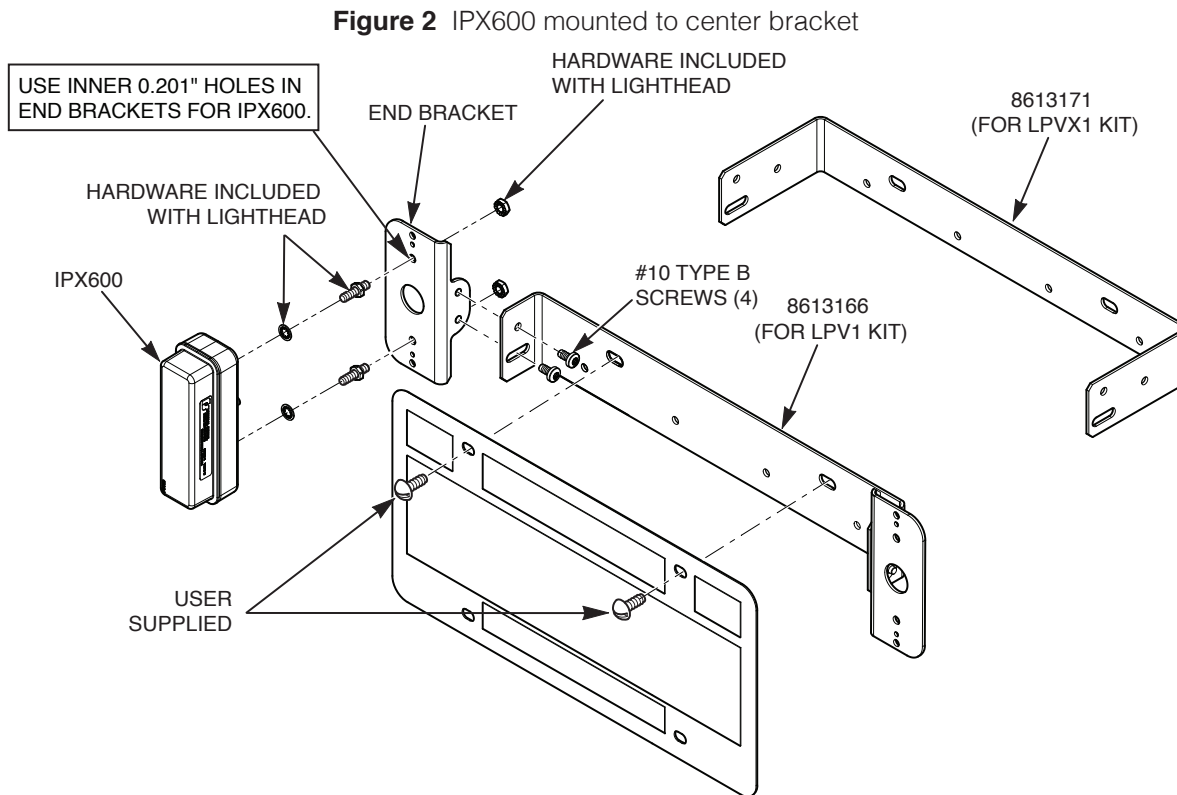

Ordering Replacement Parts

To order replacement parts, please contact your local dealer/distributor or:

Customer Support
Federal Signal Corporation
Phone: 1-800-264-3578
(7 a.m. to 5 p.m., Monday through Friday, Central Time)

Getting Technical Support and Service

For technical support and service, please contact:

Service Department
Federal Signal Corporation
Phone: 1-800-433-9132
Fax: 1-800-343-9706
Email: empserviceinfo@fedsig.com

Returning a Product to Federal Signal

Before returning a product to Federal Signal, call 800-264-3578, 800-433-9132, or 800-824-0254 to obtain a Returned Merchandise Authorization number (RMA number) (7 a.m. to 5 p.m., Monday through Friday, Central Time).

To expedite the process please be prepared with the following information:

- Your Federal Signal customer or account number.
- The purchase order number under which the items were purchased.
- The shipping method.
- The model or part number of the product being returned.
- The quantity of products being returned.
- Drop ship information as needed.
- Any estimate required.

When you receive your RMA Number:

- Write the RMA number on the outside of the box of returned items.
- Reference the RMA number on your paperwork inside of the box.
- Write the RMA number down, so that you can easily check on status of the returned equipment.

Send all material with the issued RMA Number to:

Federal Signal Corporation
2645 Federal Signal Drive
University Park, IL 60484-3167
Attn: Service Department
RMA: # _____