

INSTRUCTION SHEET FOR 350201-LAPD MIRROR MOUNT KIT

SAFETY MESSAGE TO INSTALLERS AND OPERATORS



People's lives depend on your safe installation of our products. It is important to read, understand and follow all instructions shipped with the products. In addition, listed below are some other important safety instructions and precautions you should follow:

- To properly install this mounting kit, you must have a good understanding of automotive systems, along with proficiency in the installation and use of safety warning equipment.
- DO NOT install equipment or route wiring in the deployment path of an airbag.
- When drilling into a vehicle structure, be sure that both sides of the surface are clear of anything that could be damaged.
- The mounting system should be periodically inspected to ensure that it is securely attached to the vehicle.
- File these instructions in a safe place and refer to them when maintaining and/or reinstalling the product.

Failure to follow all safety precautions and instructions may result in property damage, serious injury, or death to you or others.

A. GENERAL.

The Model 350201-LAPD is a kit for mounting the Cuda TriOptic™ light head above the rear view mirror on the Ford Crown Victoria.

B. UNPACKING.

After unpacking the kit, inspect it for damage that may have occurred in transit. If the unit has

been damaged, do not attempt to install or operate it. File a claim with the carrier, stating the extent of damage. Carefully check all envelopes, shipping labels, and tags before removing or destroying them. Ensure that the parts listed in the KIT CONTENTS LIST are included in the package.

C. KIT CONTENTS LIST.

Qty.	Description	Part No.
6	Screw, Hex Hd., #8-32 x 3/8	7000490-06
4	Screw, Hex Hd., #10 Type B	7011A122-08
6	Acorn Nut, #8-32	7054017
6	#8 Flat Washer	7072247
6	Split Lockwasher	7074A005
2	Sealing Strip, 4.25 Lg.	8572401-05
2	Sealing Strip, 2.94 Lg.	8572401-06
1	Support, Visor, Extr. Rubber	8613013
1	Mounting Bracket w/Label	8625201
1	Visor	8625127

D. INSTALLATION.

NOTE

For maximum coverage and effectiveness, the light assembly should be mounted in a horizontal orientation.

Installation can be accomplished using the supplied bracket, screws, and nuts. Determine the mounting position appropriate for installation of the mirror bracket and proceed as follows:



When installing equipment inside air bag equipped vehicles, the installer **MUST** ensure that the equipment is installed **ONLY** in areas recommended by the vehicle manufacturer. Failure to observe this warning will reduce the effectiveness of the air bag, damage the air bag, or potentially damage or dislodge the equipment, causing serious injury or death to you or others.

CAUTION

Before drilling holes in ANY part of vehicle, be sure that both sides of the mounting surface are clear of parts that could be damaged, such as brake lines, fuel lines, electrical wiring or other vital parts.

Install the unit only in an adequately ventilated area. Never install near heater ducts.

1. See figure 1. Following the directions in the vehicle manufacturer's service manual, remove the headliner far enough to access the roof brace near the windshield. Using the bracket as a template, mark the four mounting hole locations.

CAUTION

Drill only through the brace – do not drill through the roof.

2. Center punch the marks and drill four 9/64" holes. It may be necessary to use a right angle drill for the two forward facing holes.

3. Secure the mirror bracket to the roof brace with the four #10 x1/2 hex head, type B screws.

4. Reinstall the headliner.

5. See figure 2. Locate the opening in the specified mounting bolt channels and drop in two #8-32 hex head screws per channel.

6. Attach the Cuda TriOptic light head to the mirror bracket using four washers, four split washers, and four acorn nuts supplied with the mounting kit.

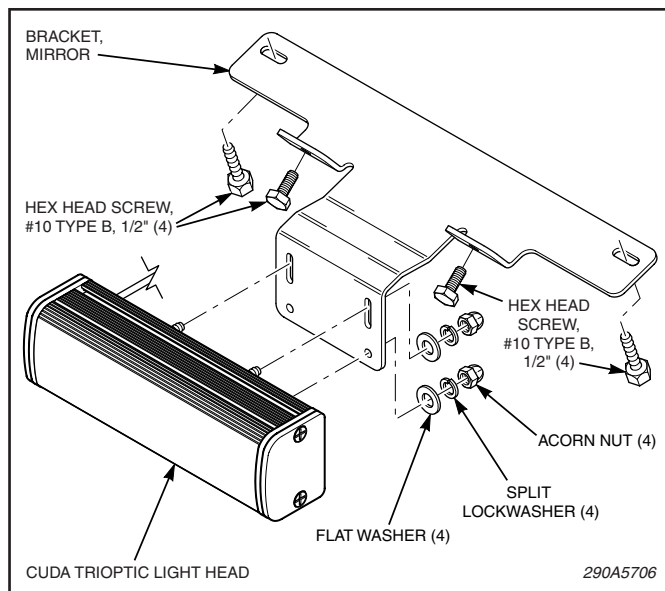

Figure 1.

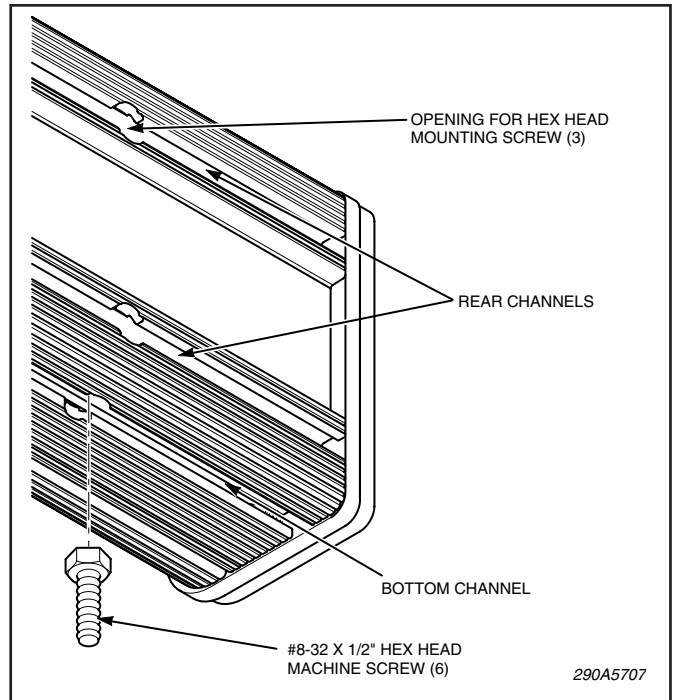

Figure 2.

7. See figure 3. Attach the visor to the Cuda TriOptic light head using two flat washers, two split washers, and two acorn nuts.

E. ELECTRICAL.

Perform the electrical connections as described in the instructions packed with the light assembly. Test the light for proper operation.

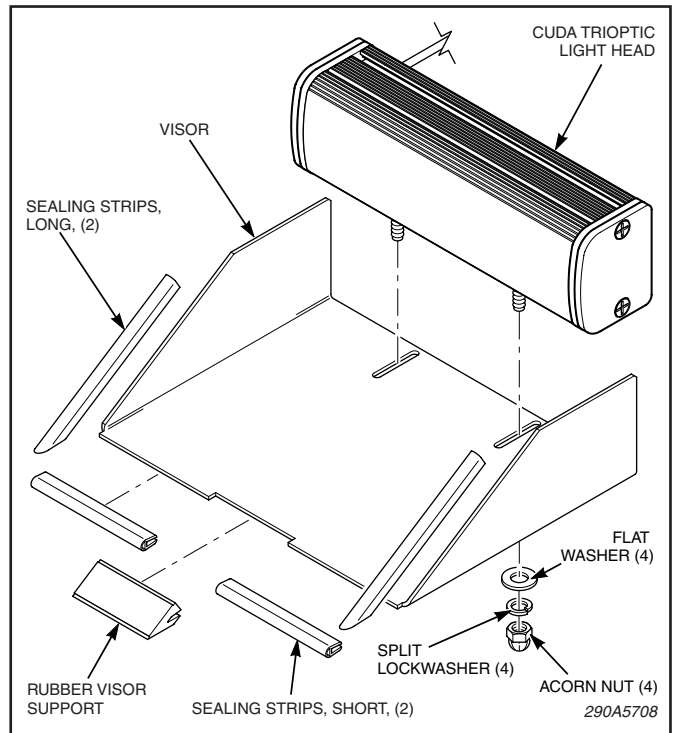

Figure 3.

F. OPERATION.

SAFETY MESSAGE TO OPERATORS



People's lives depend on your safe use of our products.

Listed below are some important safety instructions and precautions you should follow:

- **Although your warning system is operating properly, it may not completely be effective. People may not see or heed your warning signal. You must recognize this fact and continue driving cautiously.**
- **Also, situations may occur which obstruct your warning signal when natural or man-made objects are between your vehicle and others, such as raising your hood or trunk lid. If these situations occur, be especially careful.**
- **At the start of your shift, you should ensure that the signal is securely attached and operating properly.**
- **Products attached to this bracket contain high intensity LED devices. To prevent eye damage, DO NOT stare into the light beam at close range.**

Failure to follow these safety precautions may result in property damage, serious injury, or death to you, to passenger, or to others.

RETAIN AND REFER TO THIS MESSAGE

G. MAINTENANCE.

Check periodically to ensure that all bracket fasteners are secure and that the intended light direction is maintained.

H. REPLACEMENT PARTS.

Contact your local dealer/distributor for replacement parts availability or contact the Federal Signal Service Department at:

Service Department
Federal Signal Corporation
2645 Federal Signal Drive
University Park, IL 60466
800-433-9132
800-343-9706 (fax)
empserviceinfo@fedsig.com

Copyright 2006 Federal Signal Corporation