

**INSTALLATION AND MAINTENANCE INSTRUCTIONS  
FOR  
JETSONIC® MODELS JS AND JSL  
LIGHT BAR**

**SAFETY MESSAGE TO INSTALLERS  
OF  
FEDERAL SIGNAL LIGHT SYSTEMS**

People's lives depend on your safe installation of our products. It is important to read, understand and follow all instructions shipped with the products. In addition, listed below are some other important safety instructions and precautions you should follow:

- To properly install a light assembly: you must have a good understanding of automotive electrical procedures and systems, along with proficiency in the installation and use of safety warning equipment.
- When drilling into a vehicle structure, be sure that both sides of the surface are clear of anything that could be damaged.
- A light system is a high current device. In order for it to function properly, a separate ground connection must be made. If practical, it should be connected to the negative battery terminal. At a minimum, it may be attached to a solid metal body or chassis part that will provide an effective ground path as long as the light system is to be used.
- Locate light system controls so the VEHICLE and CONTROLS can be operated safely under all driving conditions.
- You should frequently inspect the light system to ensure that it is operating properly and that it is securely attached to the vehicle.
- File these instructions in a safe place and refer to them when maintaining and/or re-installing the product.

Failure to follow all safety precautions and instructions may result in property damage, serious injury, or death to you or others.

**I. UNPACKING.**

After unpacking the JetSonic light bar, inspect it for damage that may have occurred in transit. If the unit has been damaged, file a claim immediately with the carrier, stating the extent of damage. Carefully check all envelopes, shipping labels and tags before removing or destroying them.

**II. INSTALLATION.**

The light bar is completely wired at the factory and does not require any additional internal wiring. All the conductors necessary for control of any and all basic and optional functions are contained in the cable.

The basic light functions of the unit must be controlled by a user supplied control head.

Before proceeding, ensure that the light bar has been installed on the vehicle roof in accordance with the instructions packed with the mounting kit. Route the light bar cable as described below.

**WARNING**

Light system controls must be located so that VEHICLE and CONTROLS can be operated safely under all driving conditions.

A. Route the control cable into the vehicle and under the dash, near the eventual location of the user-supplied control head.

B. For proper light operation, the control cable must be properly terminated inside the user supplied control head. Using figure 1 as a guide, make the appropriate electrical connections shown in Table 1. Ensure that the lines are adequately fused as shown in figure 1.

**NOTE**

Any of the light bar functions can be activated by applying 12VDC to the appropriate control line. The heavy black lead (-) must be connected to vehicle ground, to perform a function check.

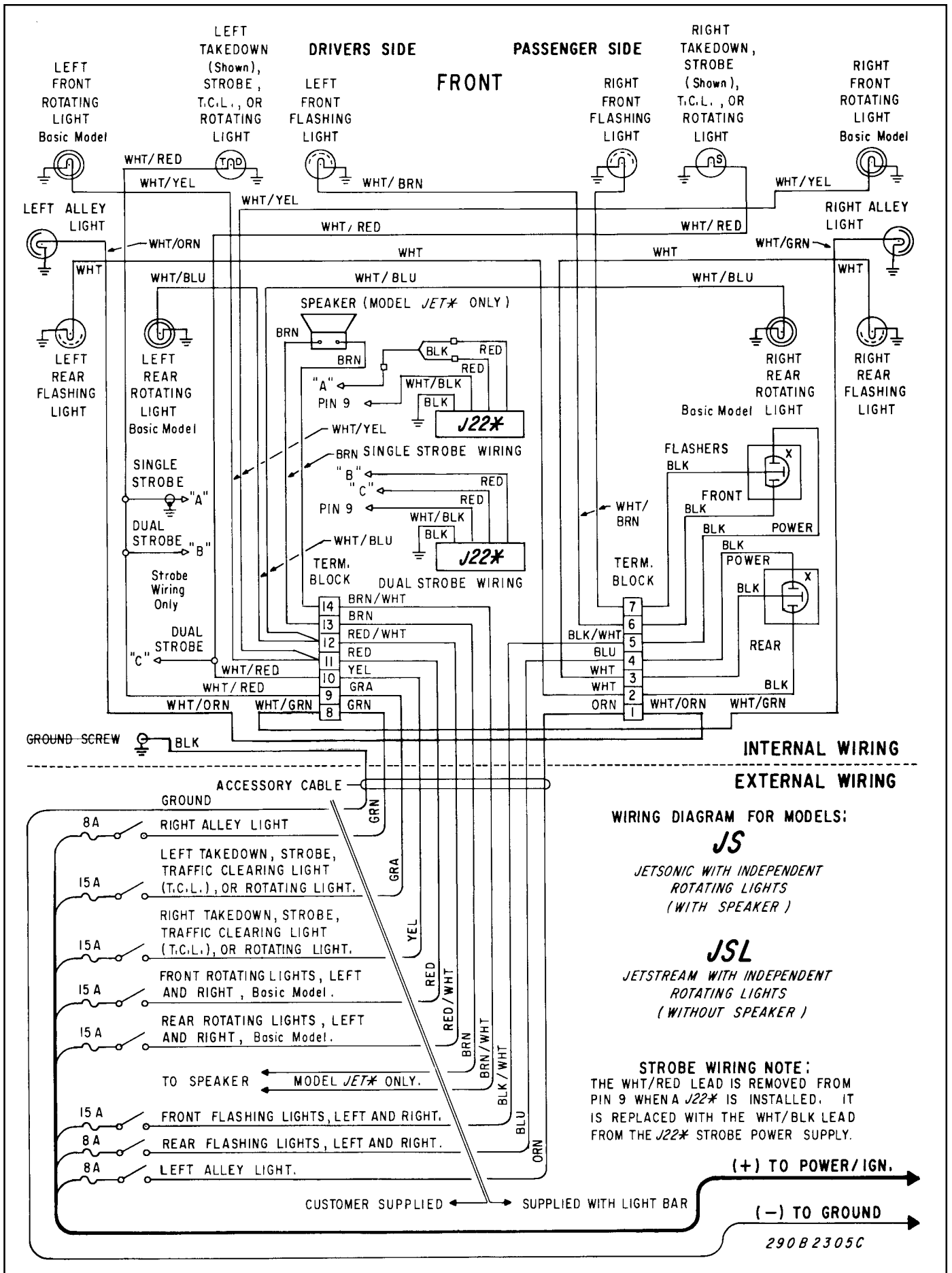

Figure 1. Wiring Diagram.

Table 1. Electrical Connections.

Wire Color	Functions
RED/WHT	Rear Rotating Lights
BRN/WHT	Speaker
BRN	Speaker
BLU	Rear Amber (Flashing)
ORN	Left Alley
YEL	Front (Flashing), Takedown, Strobe, Traffic Clearing Light
GRN	Right Alley
GRY	Takedown, Front (Flashing), Strobe, Traffic Clearing Light
RED	Front Rotating Lights
BLK	Power (-)
BLK/WHT	Takedown, Front (Flashing), Strobe

**NOTE**

If front cut-off feature is used, use DPDT (Center Off) switch and wire as shown. If front cut-off feature is not used, use SPST switch and connect RED and RED/WHT cable wires to same switch terminal as shown in figure 2.

**WARNING**

An indicator lamp must be used with the front cut-off feature to indicate that front cut-off is being used. Failure to do so may result in property damage, serious injury, or death to you or others.

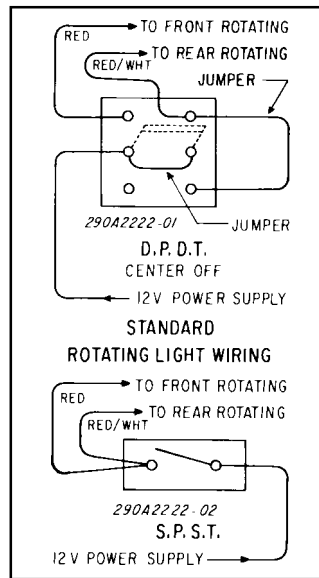

Figure 2. Switch Wiring.

C. Connect the black lead to chassis ground.

D. Connect the light bar's red power lead to a fuse or circuit breaker rated at 50 amperes. Connect the other side of the fuse /circuit breaker to the +12VDC supply.

**III. BASIC MAINTENANCE.**

**WARNING**

High voltages are present inside the light bar, when the strobe light option is installed. Wait at least ten (10) minutes, after shutting off power, before servicing this unit. Failure to do so may result in property damage, serious injury, or death to you or others.

**A. Cleaning the Plastic Domes.**

Ordinary cleaning of the plastic domes can be accomplished by using mild soap and a soft rag. Should fine scratches or a haze appear on the domes, they can ordinarily be removed with a mild, high quality, automotive rubbing compound.

**CAUTION**

The use of other materials such as strong detergents, solvents, petroleum products, etc. can cause crazing (cracking) of the plastic domes.

**B. Lamp Replacement.**

**WARNING**

A serious injury may result if lamp is touched when hot. Always allow lamp to cool before removing. Halogen lamps are pressurized and if broken can result in flying glass. Always wear gloves and eye protection when handling the lamps.

**CAUTION**

Service life of lamp will be shortened if glass portion is touched. If glass has been handled, clean carefully with a grease solvent.

See figure 3. To replace the lamp, Twist to unlock and then pull the defective lamp out of the socket. Install a new lamp of the same type in the socket.

**C. Cleaning Reflectors and Mirrors.**

Use a soft tissue to clean the reflector and mirrors. Avoid heavy pressure and the use of caustic or petroleum base solvents which will scratch or dull the surface.

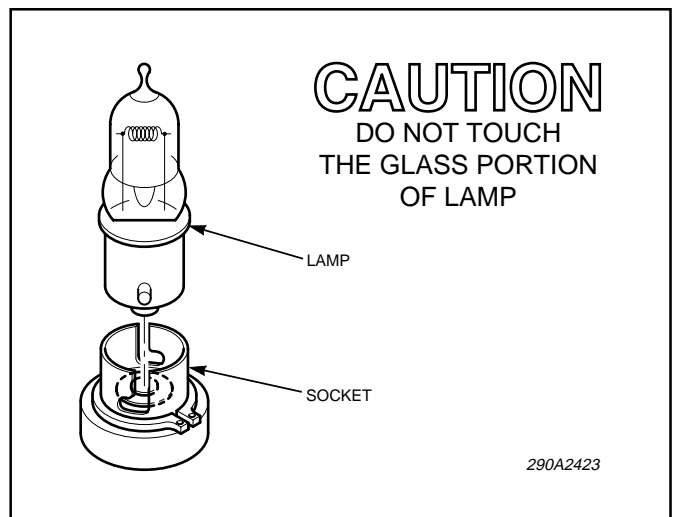

Figure 3. Lamp Replacement Diagram.

#### D. Strobe Power Supply Replacement.

### WARNING

High voltages are present inside the light bar, when the strobe light option is installed. Wait at least ten (10) minutes, after shutting off power, before servicing this unit. Failure to do so may result in property damage, serious injury, or death to you or others.

The strobe light power supply does not contain any user serviceable parts. Should a breakdown in the power supply occur, it should be returned to Federal for repair and replaced. To remove the power supply, proceed as follows:

1. Unplug the connector from the power supply.
2. Remove the two #10 screws which secure the power supply.
3. Install the new power supply by performing the previous steps in reverse order.

#### E. Speaker Driver and Cone Replacement.

To replace the speaker driver and cone, proceed as follows (see figure 4):

1. Remove the grille and rear cover from the speaker housing.
2. Unscrew the cone, being careful not to lose the five (5) washers.
3. Unscrew the wirenuts which connect the driver lead wires to the light assembly feed wires.
4. Remove the two (each) 1/4-20 screws, washers and lockwashers which secure the driver to the housing.

5. Remove the driver, being careful not to lose the two (2) washers.

6. Remove the leads from the old driver and connect to the new driver. 58-watt driver must be unsoldered and then re-soldered.

7. Reinstall the driver. Ensure that washers are installed correctly (see figure 4). Reconnect the driver lead wires to the light assembly feed wires. Secure connections with wirenuts.

8. Reinstall cone. Ensure that washers are installed correctly (see figure 4).

9. Replace grille and rear cover (removed in step 1).

#### IV. ALLEY LIGHT ADJUSTMENT.

The alley lights may be adjusted up to 7° toward the front or rear. To adjust, loosen the center screw and rotate the reflector and socket assembly to the required angle. Tighten screw after completing adjustment.

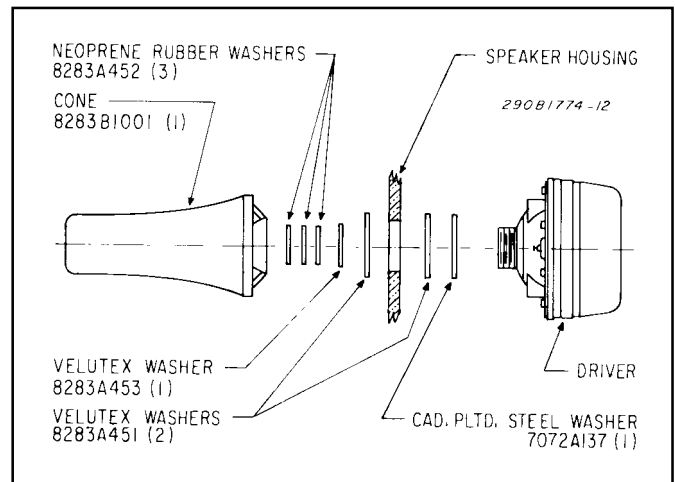

Figure 4. Speaker Driver and Cone Replacement.