

INSTRUCTION SHEET FOR STROBE SUCTION CUP MOUNT KIT

SAFETY MESSAGE TO INSTALLERS AND USERS

⚠ WARNING

People's lives depend on your safe installation of our products. It is important to read, understand and follow all instructions shipped with the products. In addition, listed below are some other important safety instructions and precautions you should follow:

- **To properly install this light: you must have a good understanding of automotive electrical procedures and systems, along with proficiency in the installation and use of safety warning equipment.**
- **Locate light control so the VEHICLE and CONTROL can be operated safely under all driving conditions.**
- **Do not attempt to activate or deactivate light control while driving in a hazardous situation.**
- **You should frequently inspect the light system to ensure that it is operating properly and that it is securely attached to the vehicle.**
- **File these instructions in a safe place and refer to them when maintaining and/or reinstalling the product.**

Failure to follow all safety precautions and instructions may result in property damage, serious injury, or death to you or others.

I. UNPACKING.

After unpacking the kit, examine it for damage that may have occurred in transit. If the equipment

has been damaged, do not attempt to install or operate it, file a claim immediately with the carrier stating the extent of the damage. Carefully check all envelopes, shipping labels and tags before removing or destroying them.

II. KIT CONTENTS LIST.

Description	Qty.
Bottom, Base	1
Cup, Suction	1
Scr, Cap Hex Hd., 3/8-16	1
Scr, Rhms, #10	3
Washer, Flat, 3/8	1
Lockwasher, Int. Tth., 3/8	1
Plug Assembly	1

III. INSTALLATION.

A. Connect the plug assembly's ribbed lead to the positive terminal on the base of the light. Connect the plug assembly's smooth lead to the negative terminal on the base of the light.

B. See figure 1. Drill a .380" hole at the center of the base bottom.

C. Secure the suction cup to the base bottom using the 3/8" bolt, lockwasher, flat washer, and nut as shown in figure 1.

D. Secure the assembled base bottom and suction cup to the base of the light assembly using the included 10-32 x 3/4" screws and the #10 nuts and lock washers included with the light assembly (see figure 1).

E. Route the plug assembly's wire through the cable exit hole.

F. Test for proper operation.

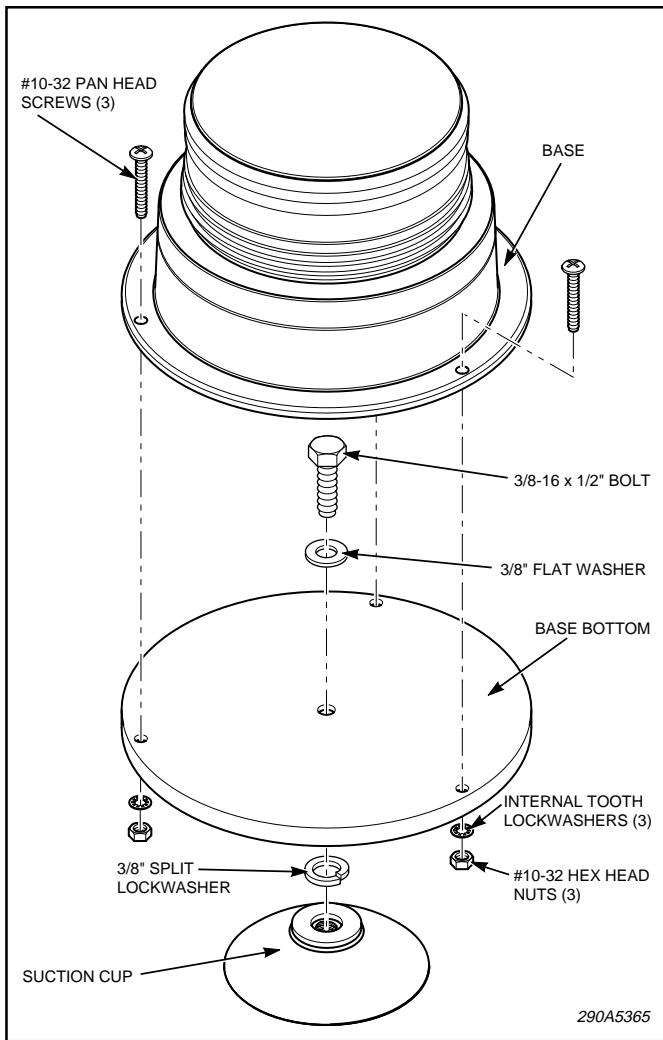

Figure 1.

IV. OPERATION.

Suction cup mounting provides a secure, temporary mounting method for most installations. However, it is not intended for use on exterior of a moving vehicle.

⚠ WARNING

Because vehicle roof construction and driving conditions vary, Federal does not recommend driving a vehicle with a suction cup mounted warning light installed. The light could fly off the vehicle causing injury or damage. Repair of damage incurred because of ignoring this warning shall be the sole responsibility of the user.

Holding power of suction cup mounting systems is dependent upon surface finish and surface flatness of the mounting surface. Therefore, to promote proper suction cup mounting:

- **Mounting surface and suction cups must be kept clean, dry, and free of foreign particles that prevent good surface contact.**
- **Ensure that mounting surface is flat.**
- **Suction cup mounting system should not be used on vehicles with vinyl tops.**
- **To prevent loosening of light assembly on mounting surface, quick acceleration and hard stops should be avoided.**

Place the light on a level surface. Ensure that the light is placed to promote maximum coverage and range of the light's warning signal. Insert the plug into the vehicle's cigarette lighter receptacle.

Copyright 2005 Federal Signal Corporation