

INSTALLATION INSTRUCTIONS
FOR
#350213-06 Cuda TriOptic™ MOUNTING BRACKET

SAFETY MESSAGE TO INSTALLERS

 **WARNING**

The lives of people depend on your proper installation and servicing of Federal products. It is important to read, understand, and follow all instructions shipped with the products. In addition, listed below are some other important safety instructions and precautions you should follow:

Before Installation

Qualifications

- To properly install this mounting kit, you should have a good understanding of automotive electrical procedures and systems, along with the proficiency in the installation and use of safety warning equipment.
- Never attempt to install aftermarket equipment that connects to the vehicle wiring, without reviewing a vehicle wiring diagram – available from the vehicle manufacturer. Insure that your installation will not affect vehicle operation and safety functions or circuits.

During Installation

- DO NOT install equipment or route wiring in the deployment path of an air bag.
- Locate the light control so the VEHICLE and CONTROL can be operated safely under all driving conditions.

After Installation

- Do not attempt to activate or deactivate the light control while driving in a hazardous situation.
- You should frequently inspect the light mounting assembly to ensure that it is operating properly and that it is securely attached to the vehicle.
- This product contains high intensity LED devices. To prevent permanent eye damage, DO NOT stare into the light beam at close range.
- Test all vehicle functions, including the Cuda TriOptic SignalMaster™ operation, and vehicle safety functions to ensure proper operation. Ensure that the installation has not affected vehicle operation or changed any vehicle safety function or circuit.
- After testing is complete, provide a copy of these instructions to the instructional staff and all operating personnel.
- File these instructions in a safe place and refer to them when maintaining and/or reinstalling the product.

Failure to follow all safety precautions and instructions may result in property damage, serious injury, or death to you or others.

A. GENERAL.

The #350213-06 mounting kit is designed for use in conjunction with the Federal Signal 351000 and 352000 series CudaTriOptic light heads. This is a general purpose bracket used for mounting up to two light heads in a variety of configurations onto a flat surface. The bracket is manufactured from powder coated aluminum and is designed for both interior and exterior use.

B. UNPACKING.

After unpacking this mounting kit, carefully inspect for damage that may have occurred during transit. If the kit is damaged, file a claim immediately with the carrier, stating the extent of damage. Carefully check all envelopes, shipping labels and tags before removing or destroying them

C. KIT CONTENTS LIST.

Qty.	Description	Part No.
1	Mounting Bracket	8625251

D. INSTALLATION.

⚠ WARNING

This product is intended for supplemental warning and for use in conjunction with an approved primary warning light system.

When installing equipment inside air bag equipped vehicles, the installer MUST ensure that the equipment is installed ONLY in areas recommended by the vehicle manufacturer. Failure to observe this warning will reduce the effectiveness of the air bag, damage the air bag, or potentially damage or dislodge the equipment, causing serious injury or death to you or others.

1. Figure 1 shows a typical mounting configuration using Cuda TriOptic 351000 Series and 352000 Series LED Light Heads (not included).

2. See figure 2. Attach the mounting bracket securely to the intended mounting surface using the appropriate mounting hardware (not included).

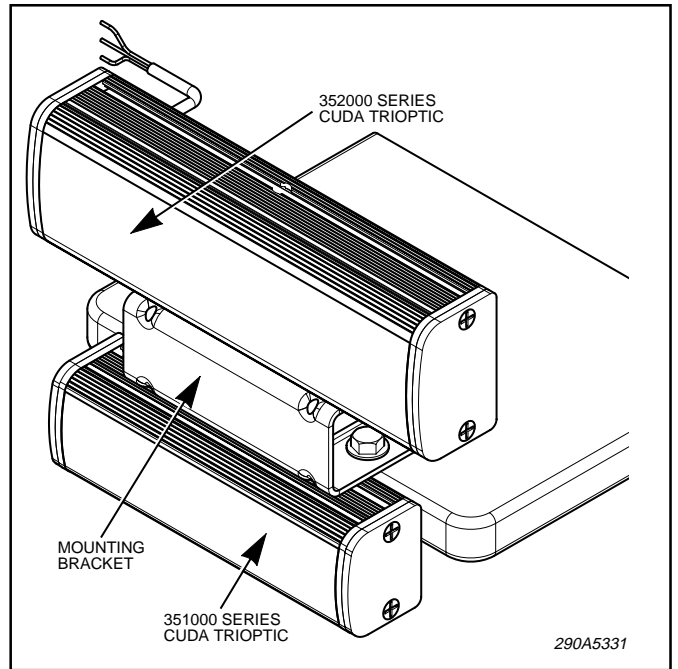

Figure 1.

3. See figure 3. Attach the light head(s) to the bracket using the hardware supplied with the lights.

4. See the light head instructions for electrical connection instructions.

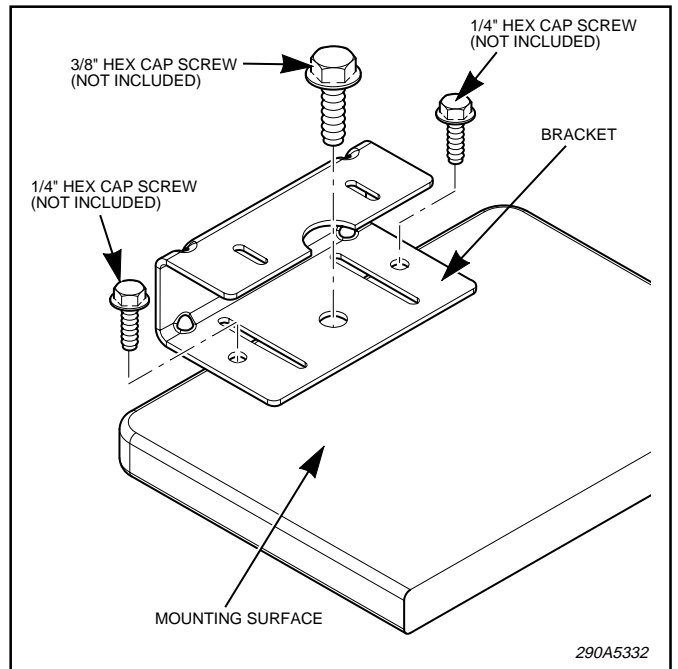

Figure 2.

E. OPERATION.

SAFETY MESSAGE TO OPERATORS

⚠ WARNING

People's lives depend on your safe use of our products.

Listed below are some important safety instructions and precautions you should follow:

- Although your warning system is operating properly, it may not completely be effective. People may not see or heed your warning signal. You must recognize this fact and continue driving cautiously.
- Also, situations may occur which obstruct your warning signal when natural or man-made objects are between your vehicle and others, such as: raising your trunk lid. If these situations occur, be especially careful.
- At the start of your shift, you should ensure that the signal is securely attached and operating properly.
- Products attached to this bracket contain high intensity LED devices. To prevent permanent eye damage, DO NOT stare into the light beam at close range.

Failure to follow these safety precautions may result in property damage, serious injury, or death to you, to passengers, or to others.

RETAIN AND REFER TO THIS MESSAGE

F. MAINTENANCE.

Check periodically to ensure that all bracket fasteners are secure and that the intended light direction is maintained.

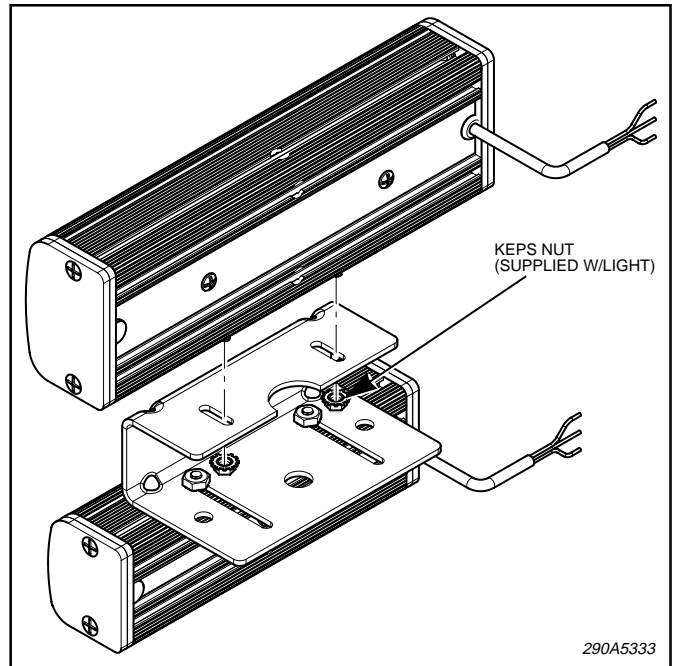

Figure 3.

G. REPLACEMENT PARTS.

Contact your local dealer/distributor for replacement parts availability or contact the Federal Signal Service Department at:

Service Department
Federal Signal Corporation
2645 Federal Signal Drive
University Park, IL 60466

800-433-9132
800-343-9706 (fax)
empserviceinfo@fedsig.com

Copyright 2005 Federal Signal Corporation