

**INSTRUCTION SHEET  
FOR 3M OPTICOM 792 EXTERNAL BRACKET KIT  
FOR USE WITH VECTOR® & VISION® LIGHT BARS**

**SAFETY MESSAGE TO INSTALLERS AND USERS**

**⚠ WARNING**

**People's lives depend on your safe installation of our products. It is important to read, understand and follow all instructions shipped with the products. In addition, listed below are some other important safety instructions and precautions you should follow:**

- **To properly install light bar, you must have a good understanding of automotive systems, along with proficiency in the installation and use of safety warning equipment.**
- **DO NOT install equipment or route wiring in the deployment path of an air bag.**
- **When drilling into a vehicle structure, be sure that both sides of the surface are clear of anything that could be damaged.**
- **You should frequently inspect the light system to ensure that it is operating properly and that it is securely attached to the vehicle.**
- **Refer to the instruction sheets packed with the light and the Opticom System for proper electrical connection.**
- **File these instructions in a safe place and refer to them when maintaining and/or reinstalling the product.**

**Failure to follow all safety precautions and instructions may result in property damage, serious injury, or death to you or others.**

**I. GENERAL.**

This kit is designed for installation on Federal Signal Vision® and Vector® light bars. This kit mounts a 3M Opticom Model 792 Series Emitter externally on the light bar on either the driver's or passenger's side.

**II. UNPACKING.**

After unpacking the light assembly, inspect it for damage that may have occurred in transit. If the unit has been damaged, do not attempt to install or operate it. File a claim immediately with the carrier, stating the extent of damage. Carefully check all envelopes, shipping labels, and tags before removing or destroying them.

**III. KIT CONTENTS LIST.**

Qty.	Description	Part No.
1	Bracket, Opticom	8572486
1	Screw, 1/4-20 Hex Head	7000A311-12
2	Washer, Flat, 1/4"	7072A024
1	Lockwasher, Split, 1/4"	7074A016
1	Nut, 1/4-20, Hex	7059A020
2	Bolt, Carriage Hd.	7004028-08
2	Gasket, Friction	8567096

**IV. BRACKET INSTALLATION.**

**NOTE**

Refer to the Instructions packed with the 3M Opticom Emitter for electrical installation instructions.

A. Prior to installing the mounting feet, turn the light assembly over so that the bottom of the bar faces up. The unit should be placed on some soft rags or cardboard to avoid marring the plastic domes.

B. See figure 1. Using the 1/4-20 hex head bolt, 1/4" flat washers, 1/4" lockwasher, and 1/4" hex nut,

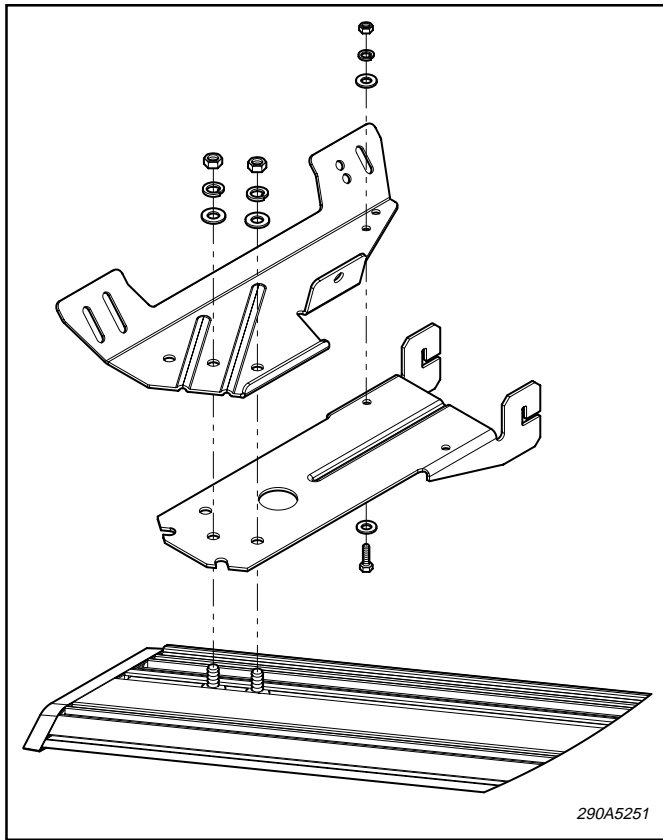

Figure 1.

attach the Opticom bracket to the desired mounting foot (right or left side). Attach the mounting foot to the bar with the hardware supplied with the light bar. Complete the light bar installation according to the light bar mounting instructions.

C. See figure 2. Attach the friction gasket to the friction plate, then attach the emitter with the carriage head bolts and hardware supplied with the emitter. Complete the electrical connections as described in the instructions provided with the emitter.

D. Check for proper operation of all functions.

**Copyright 2005 Federal Signal Corporation**

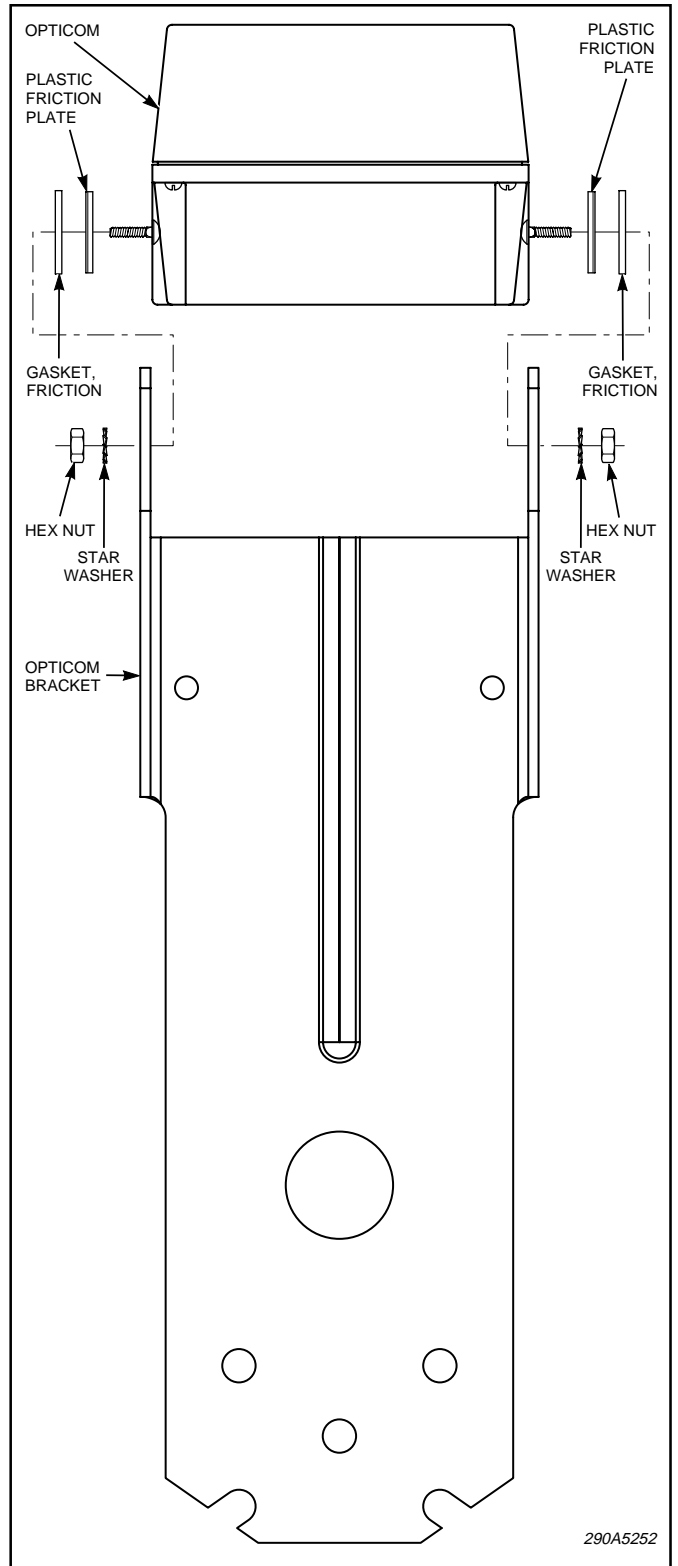

Figure 2.