

## INSTRUCTION SHEET FOR MODEL SW300 SWITCH MODULE

### SAFETY MESSAGE TO INSTALLERS



People's lives depend on your safe installation of our products. It is important to read, understand and follow all instructions shipped with the products. In addition, listed below are some other important safety instructions and precautions you should follow:

- To properly install the equipment described in this instruction sheet: you must have a good understanding of automotive electrical procedures and systems, along with proficiency in the installation and use of safety warning equipment.
- **DO NOT** install equipment or route wiring in the deployment path of an air bag.
- Locate the switch module so the **VEHICLE** and **CONTROLS** can be operated safely under all driving conditions.
- When drilling into a vehicle structure, be sure that both sides of the surface are clear of anything that could be damaged.
- File these instructions in a safe place and refer to them when maintaining and/or re-installing the product.

**Failure to follow all safety precautions and instructions may result in property damage, serious injury, or death to you or others.**

#### A. GENERAL.

The Model SW300 Switch Module is designed to accommodate six rocker type switches, which are used to control various vehicle mounted devices. Six legend inserts are installed above the switches as shown in figures 1 and 2. Six additional legend inserts are included as part of the accessory kit packed with the Switch Module.

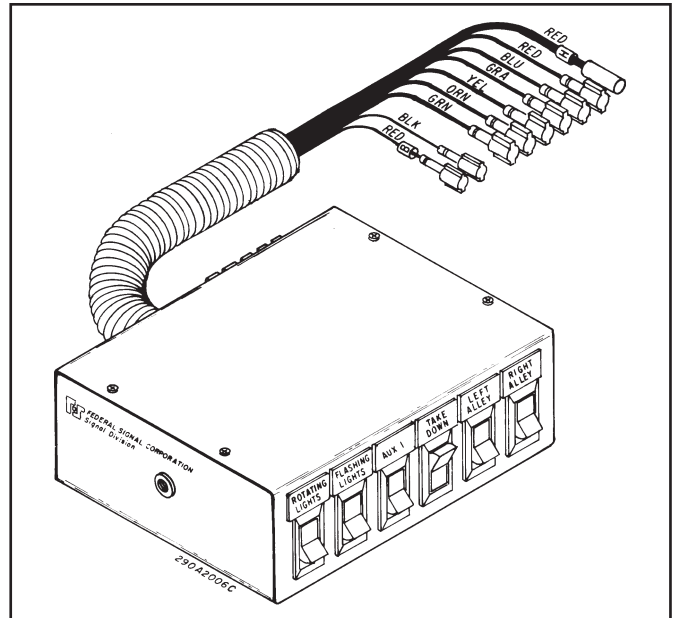

Figure 1. Model SW300 Switch Module.

A thermal lockout type circuit breaker, rated at 40 amperes, protects the rotating light circuit (circuit 1). The circuit 1 load current flows through the contacts of a relay rated at 40 amperes (K1). The other circuits (2 through 6) are each protected by automotive blade type fuses rated at 20 amperes.

The Switch Module is designed to be installed on a vehicle mounting surface via a trunion mounting bracket. It can be installed on top of Federal Model PA300 electronic sirens with the hardware included in the accessory kit, and secured to the mounting surface via the bracket included with the electronic siren. Federal has available an optional trunion mounting bracket kit (Model SW-BK) which allows the Switch Module to be installed by itself.

Six SPST rocker switches are included with the Switch Module. An optional SPST momentary push-button switch is available by ordering SW14. The switch must be mounted independently of the Switch Module.

The switches are rated at 20 amperes @ 12Vdc. dimensions (HWD) are 2-3/16" x 6-1/16" x 5-7/8" (including fuses). Weight is 2 pounds.

## B. INSTALLATION.

### **WARNING**

When installing equipment inside air bag equipped vehicles, the installer **MUST** ensure that the equipment is installed **ONLY** in areas recommended by the vehicle manufacturer.

Failure to observe this warning will reduce the effectiveness of the air bag, damage the air bag, or potentially damage or dislodge the equipment, causing serious injury or death to you or others.

Before attempting installation, insure that the following parts have been included in the accessory kit.

Qty.	Description
2	Wire Ties
5	"Tinnerman" Clips
5	Shoulder Snap Rivets
1	Insulated 1/4" Male Terminal (YEL)
2	Insulated 1/4" Male Terminals (PINK)
5	Insulated 1/4" Male Terminals (BLUE)
6	Printed Legend Inserts (GRILLE & DECK LTS., COMPARTMENT, REAR LIGHTS, WORK LIGHT, STROBE, FRONT CUT OFF)

If the Switch Module will be installed by itself (not on top of a Federal electronic siren), follow the installation instructions packed with the trunion mounting bracket and disregard this paragraph. To install the Switch Module on a Model PA150, PA200 or PA300; proceed as follows (see figure 2):

1. Remove the four screws which secure the top of the Switch Module to its base. Carefully pull the top away from the base.
2. Loosen the two screws at the bottom of the electronic siren and slide the chassis a few inches out of its case.
3. Line up the front edge of the Switch Module base with the front of the electronic siren case. Fasten these units together with the three Tinnerman clips (supplied). Distribute the clips evenly across the front.
4. The three slots at the rear of the Siren Module base should now line-up with three ventilating holes in the electronic siren case. Insert a shoulder snap rivet (supplied) into each of the three Switch Module slots and electronic siren ventilating holes.

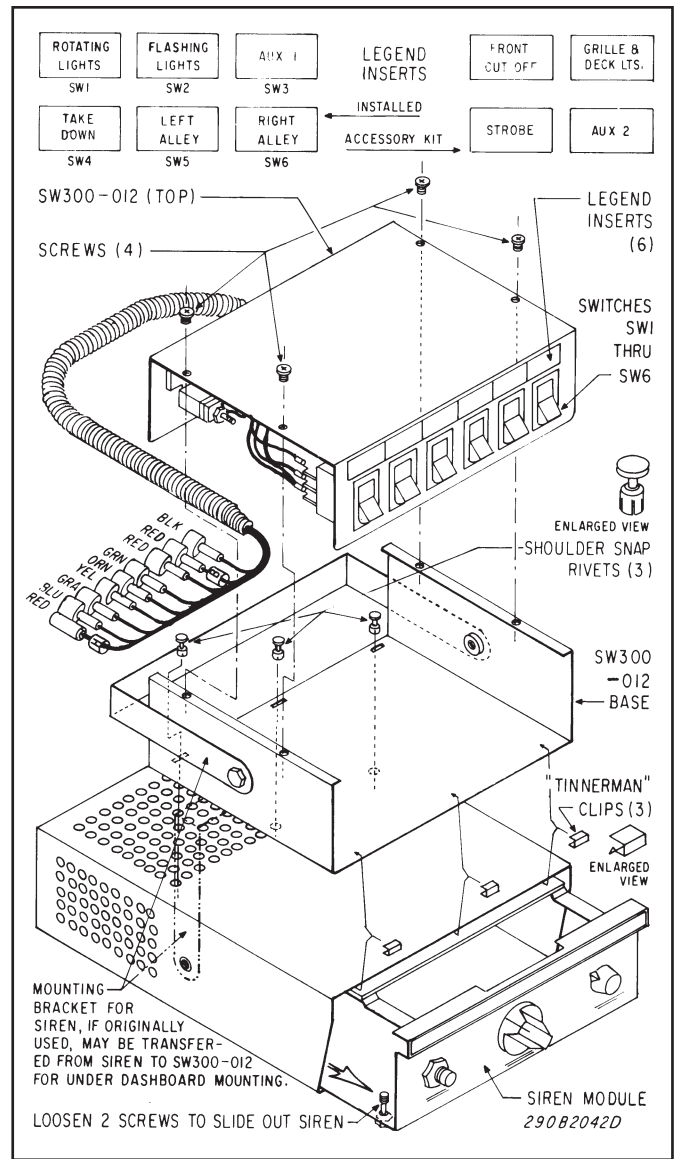

Figure 2. Installation Diagram.

5. Slide the electronic siren case back into position over the chassis and tighten the two screws loosened in step 2.
6. Replace the top of the Switch Module on its base and secure with the four screws removed in step 1.
7. Select a mounting location which allows the vehicle and all controls to be operated safely under all driving conditions.

### **CAUTION**

The unit must be installed in an adequately ventilated area. Never install near heat ducts.

8. Use the mounting bracket as a template and scribe two drill position marks at the selected mounting location.

**CAUTION**

When drilling holes in ANY part of the vehicle, ensure that both sides of the surface are clear of parts that could be damaged; such as brake lines, fuel lines, electrical wiring or other vital parts.

9. Drill two 1/4-inch diameter holes at the position marks.
10. Secure the mounting bracket to the mounting surface with (2 each) 1/4-20 x 3/4 hex. head screws, 1/4 split lockwashers and 1/4-20 hex nuts.
11. Secure the Switch Module to the mounting bracket with 1/4-20 x 3/8 hex. head screws and 1/4 split lockwashers.
12. Tilt the unit to the desired position and tighten the 1/4-20 x 3/8 hex. head screws.

**C. WIRING.**

Figure 3 illustrates the correlation of the color-coded wires to a corresponding switch. Example: Switch 1 (switch at extreme left) controls the signal at the unmarked red wire.

Insulated female terminals, which mate with the male terminals on the Switch Module wiring harness, have been included in the accessory kit to facilitate installation. These terminals should be installed on the end of the lead wire which will mate with the wiring harness lead wire. Use the yellow terminal for 12GA red wire, the blue terminals for the colored 14GA wires, and the two pink terminals for the red and black 18GA wires.

**NOTE**

When using the insulated terminals, insure that all crimps are secure and that the male/female terminals slip into each other and not over.

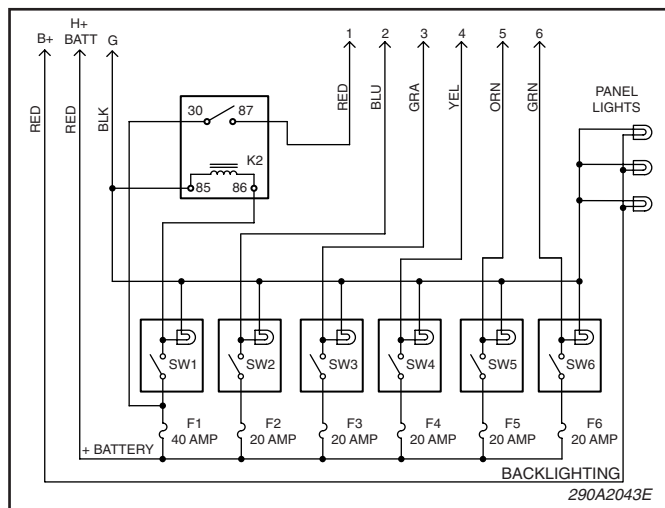

Figure 3. Wiring Diagram.

To properly wire the Switch Module, perform the following procedure:

1. See figure 3 to correlate the color-coded wires to the corresponding switches. Use 12GA wire and connect SW1 (unmarked red wire) to the applicable accessory load. Use 14GA wire and connect SW2 through SW6 to the applicable accessory load.
2. Use 18GA wire and connect the ground lead (black wire) to a RELIABLE vehicle ground. Each switched device MUST be grounded with a separate ground wire.
3. Use 18GA wire and connect the red back-lighting circuit lead "B" to the accessory terminal of the ignition switch or the vehicle instrument light circuit.
4. Power for the Switch Module can be obtained from the vehicle's power distribution center or a 100-ampere remote/reset circuit breaker located near the battery. Use 8GA wire and connect the red power lead "H" to the circuit breaker or distribution center. If power is obtained in the engine compartment, a hole will probably have to be drilled into the vehicle fire-wall. Place a grommet or similar device in the hole to protect the wire against damage from rough edges.

**CAUTION**

When drilling holes in ANY part of the vehicle, ensure that both sides of the surface are clear of parts that could be damaged; such as brake lines, electrical wiring or other vital parts.

**D. SERVICE PARTS.**

**CAUTION**

Do not exceed 20A fuse ratings when replacing fuses. Failure to comply may damage the unit.

Part No.	Description
*122A242	Switch, Rocker, SPST
*131A175	Relay, 40A (K1)
*152123	Breaker, Circuit, 40A (F1)
*148A142	Fuse, 20A, Automotive Blade
*288515	Kit, Accessory, SW300
*124A058	Kit, Accessory, SW300 Label
*149A121	Lamp
*143A117	Fuseholder
*8536B945	Bracket
*131190	Relay, 20A
*288819	Lamp Replacement Kit, 12V

Copyright 2007 Federal Signal Corporation