

**INSTALLATION INSTRUCTIONS FOR
#350205 CudaTriOptic LIGHT HEAD
SWIVEL MOUNTING BRACKET KIT, 3.5" LENGTH**

SAFETY MESSAGE TO INSTALLERS



The lives of people depend on your proper installation and servicing of Federal products. It is important to read, understand and follow all instructions shipped with the products. In addition, listed below are some other important safety instructions and precautions you should follow:

Before Installation

Qualifications

- To properly install this mounting hardware, you must have a good understanding of automotive systems, along with proficiency in the installation and use of safety warning equipment.
- Never attempt to install aftermarket equipment which connects to the vehicle wiring, without reviewing a vehicle wiring diagram – available from the vehicle manufacturer. Insure that your installation will not affect vehicle operation and safety functions or circuits.

During Installation

- DO NOT install equipment or route wiring in the deployment path of an air bag.
- When drilling into a vehicle structure, be sure that both sides of the surface are clear of anything that could be damaged.
- When drilling into a vehicle structure, be sure that both sides of the surface are clear of anything that could be damaged.
- Locate light control so the VEHICLE and CONTROL can be operated safely under all driving conditions.

After Installation:

- Do not attempt to activate or deactivate light control while driving in a hazardous situation.
- You should frequently inspect the light mounting assembly to ensure that it is operating properly and that it is securely attached to the vehicle.
- This product contains high intensity LED devices. To prevent eye damage, DO NOT stare into the light beam at close range.
- Test all vehicle functions, including the CudaTriOptic light head operation, and vehicle safety functions to ensure proper operation. Ensure that the installation has not affected vehicle operation or changed any vehicle safety function or circuit.
- After testing is complete, provide a copy of these instructions to the instructional staff and all operating personnel.
- File these instructions in a safe place and refer to them when maintaining and/or reinstalling the product.

Failure to follow all safety precautions and instructions may result in property damage, serious injury, or death to you or others.

A. GENERAL.

The #350205 mounting kit is designed for use in conjunction with the Federal Signal CudaTriOptic family light heads (see the light head's instruction sheet). The kit is designed for mounting within a vehicle's interior. The bracket is supplied with mounting hardware and allows the unit to swivel at a 270° angle range. The assembled unit may be mounted in the horizontal, or vertical, position with the cabling exiting from either side, or the rear, of the CudaTriOptic light head.

B. UNPACKING.

After unpacking the kit and the light head, inspect them for damage that may have occurred in transit. If either the kit or the unit has been damaged, or missing a part, do not attempt to install or operate it. File a claim immediately with the carrier, stating the extent of damage. Carefully check all envelopes, shipping labels and tags before removing or destroying them. Ensure that all parts in the following KIT CONTENTS LIST have been included.

C. KIT CONTENTS LIST.

Qty.	Description	Part Number
2	Bracket, CudaTriOptic	8625174
2	Screw, 1/4-20 x 7/16", Hex Head	7000A323-07
2	Lockwasher, Ext. Tooth, 1/4"	7075A007

D. INSTALLATION.



This product is intended for supplemental warning and for use in conjunction with an approved primary warning light system. Consult local codes and regulations to determine if the power supply/light head combination complies with the horizontal or vertical mount positioning desired in your application.

When installing equipment inside air bag equipped vehicles, the installer MUST ensure that the equipment is installed ONLY in areas recommended by the vehicle manufacturer. Failure to observe this warning will reduce the effectiveness of the air bag, damage the air bag, or potentially damage or dislodge the equipment, causing serious injury or death to you or others.

1. First, determine which side of the unit will be attached to the mounting bracket. The fully assembled bracket is designed with a 270° swivel feature allowing the installer a wide range of mounting options.

2. The light heads are provided with a top, bottom, and two rear channels which accommodate two mounting screws (supplied with the light head unit along with two keps nuts). Slide the two mounting screws into the selected channel for mounting on the bracket with the warning label. Ensure that the light head is fully assembled if the end cap was removed to install the mounting screws.

NOTE

For a horizontal mounting, the light head unit MUST be mounted with the two drain holes facing downward for adequate condensate drainage. (See the light head's instruction sheet.)

3. See figure 1. Three sets of mounting holes are provided on the bracket to accommodate various mounting configurations. Attach the bracket to the selected channel using the previously installed screws and the two keps nuts (supplied with the light head).

CAUTION

Before drilling holes in ANY part of vehicle, be sure that both sides of the mounting surface are clear of parts that could be damaged; such as brake lines, fuel lines, electrical wiring or other vital parts.

4. Six 3/16" holes are also provided on the remaining bracket for mounting in the vehicle's interior. Use the mounting bracket as a template and scribe drill position marks onto the mounting surface as required for your particular application. Use #8 screws (not supplied) suitable for your mounting application to secure the bracket on the mounting surface. Ensure the bracket is held firmly in place to resist vibration when the vehicle is in motion.

5. Next, slide together and attach the bracket/light head assembly to the surface mounted bracket using the supplied hex head screws and locating the lockwashers between the brackets' arms. Ensure the light assembly is facing in the intended direction and tighten both screws.

6. After installation is completed, test the unit for proper operation, and test drive the vehicle to ensure that vibration does not loosen the light assembly.

CAUTION

After prolonged operation, the light head unit dissipates heat and can cause burns. Do not hold the unit in your hands for extended periods of time. Do not touch the unit during, or shortly after, operation. Always allow the unit to cool before handling.

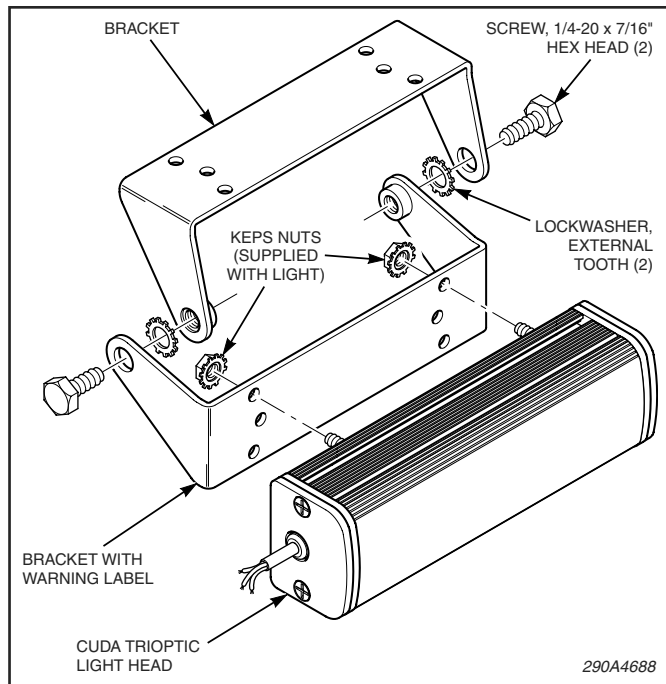

Figure 1.

E. MECHANICAL SPECIFICATIONS AND FEATURES.

Refer to the light head unit's instruction sheet.

F. ELECTRICAL SPECIFICATIONS AND FEATURES.

Refer to the light head unit's instruction sheet.

SAFETY MESSAGE TO OPERATORS



People's lives depend on your safe use of our products.

Listed below are some important safety instructions and precautions you should follow:

- **Although your warning system is operating properly, it may not be completely effective. People may not see or heed your warning signal. You must recognize this fact and continue driving cautiously.**
- **Also, situations may occur which obstruct your warning signal when natural or man-made objects are between your vehicle and others, such as: raising your hood or trunk lid. If these situations occur, be especially careful.**
- **At the start of your shift, you should ensure that the light is securely attached and operating properly.**
- **Products attached to this bracket contain high intensity LED devices. To prevent eye damage, DO NOT stare into the light beam at close range.**

Failure to follow these safety precautions may result in property damage, serious injury, or death to you, to passengers, or to others.

RETAIN AND REFER TO THIS MESSAGE

G. MAINTENANCE.

1. *General.*

Check periodically to ensure that all bracket fasteners are secure and that the intended light direction is maintained.

2. *Replacement Parts.*

This unit contains NO user replaceable components. Consult the factory regarding warranty repairs/replacement issues.

Manufactured by:
 Federal Signal Corporation
 Emergency Products Group
 2645 Federal Signal Drive
 University Park, Illinois 60466
 800-433-9132
 800-343-9704 (fax)
 emp-service-info@fedsig.com