

2562505A REV. A 311

## Safety Message to Installers and Service Personnel of Warning Light Equipment

### **⚠ WARNING**

People's lives depend on your proper installation and servicing of Federal Signal products. It is important to read and follow all instructions shipped with this product and the original product. In addition, listed below are some other important safety instructions and precautions you should follow:

- To properly install this light, you must have a good understanding of automotive electrical procedures and systems, along with proficiency in the installation and use of safety warning equipment.
- Always refer to the vehicle's service manuals when performing equipment installations on a vehicle.
- Never attempt to install aftermarket equipment that connects to the vehicle wiring without reviewing a vehicle wiring diagram available from the vehicle manufacturer. Ensure that your installation will not effect vehicle operation or mandated safety functions or circuits. Always check the vehicle for proper operation after installation.
- When drilling into a vehicle structure, be sure that both sides of the surface are clear of anything that could be damaged.
- In order for the light to function properly, a separate ground connection must be made. If practical, it should be connected to the fusible link at the front fender between the negative (–) battery terminal and chassis ground. At a minimum, it may be attached to a solid metal body or chassis part that will provide an effective ground path as long as the light system is to be used.
- Locate the light control so the VEHICLE and CONTROL can be operated safely under all driving conditions.
- If a seat is temporarily removed, verify with the vehicle manufacturer if the seat needs to be recalibrated for proper airbag deployment.
- Do not attempt to activate or deactivate the light control while driving in a hazardous situation.
- This product contains high intensity LED devices. To prevent permanent eye damage, DO NOT stare into the light beam at close range.
- You should frequently inspect the light system to ensure that it is operating properly and that it is securely attached to the vehicle.
- Do not install equipment or route wiring in the deployment path of an airbag. Failure to observe this warning will reduce the effectiveness of the airbag or potentially dislodge the equipment, causing serious injury to you or others.
- File these instructions in a safe place and refer to them when maintaining and/or reinstalling the product.

Failure to follow all safety precautions and instructions may result in property damage, serious injury, or death.

## An Overview of the VIPER SIGNALMASTER

The Federal Signal VIPER SIGNALMASTER is a directional light assembly for use in a flashing mode. The lens colors available are amber (standard), red, blue, and clear.

The VIPER SIGNALMASTER provides two distinctive directional signals: left arrow and right arrow. In addition, an alternating flash pattern produces a warning signal for use when a directional signal may not be appropriate. When a directional signal is selected, the lamps are individually illuminated in a sequential sweeping motion until all lamps are illuminated.

### **⚠ WARNING**

#### **LIGHTS FOR SECONDARY WARNING ONLY**

**These lights are for *secondary* warning only. They are not for use as a primary warning system. Failure to use these lights as intended may cause property damage, personal injury, or death.**

## Product Specifications

Input Voltage:	11 Vdc to 13.6 Vdc (12 V models)
Polarity:	Negative ground only
Dimensions:	
Height:	2.6 in (6.6 cm)
Length:	Varies
Depth:	3.4 in (8.6 cm)
Cable Length	Various

## Installing the VIPER SIGNALMASTER Light Assembly

### **NOTICE**

#### **STATIC SENSITIVE DEVICE**

**The circuitry of the VIPER SIGNALMASTER can be damaged or destroyed by electrostatic discharge (ESD). To prevent ESD, observe anti-static procedures during installation.**

Install the light assembly as described in the instructions included with the mounting kit. Route the cables to the planned location of the control unit.

## Installing the Control Unit and Completing the Wiring

### **⚠ WARNING**

#### **UNIT REQUIRES VENTILATION**

**The control unit needs to radiate heat. Do not install it in an area where it cannot dissipate heat into the air. Do not mount the unit near a heater duct or under the hood.**

### **NOTICE**

#### **REVERSE POLARITY/MISWIRING**

**Reverse polarity or incorrect voltage may damage the light. To avoid damage to the light, ensure that the battery voltage is the same as the voltage rating of the light and that the correct polarity is observed.**

**NOTE:** Plan all wiring and cable routing before selecting a mounting location for the control unit.

Install the control unit and complete the wiring as described in the instructions included with the control unit.

**NOTE:** For the Model 320810-RB, connect the blue and white wire to the Auxiliary portion of the control unit. Then follow the instructions included with the control unit.

## Replacing a Lens

1. Remove the four #6-32 screws that secure the lens to the housing (Figure 1).
2. Remove the lens and the gasket.

### NOTICE

#### DO NOT OVERTIGHTEN SCREWS

To avoid damage to the PC boards, do not overtighten the screws.

3. Secure the new lens and gasket to the housing with the four #6-32 screws.

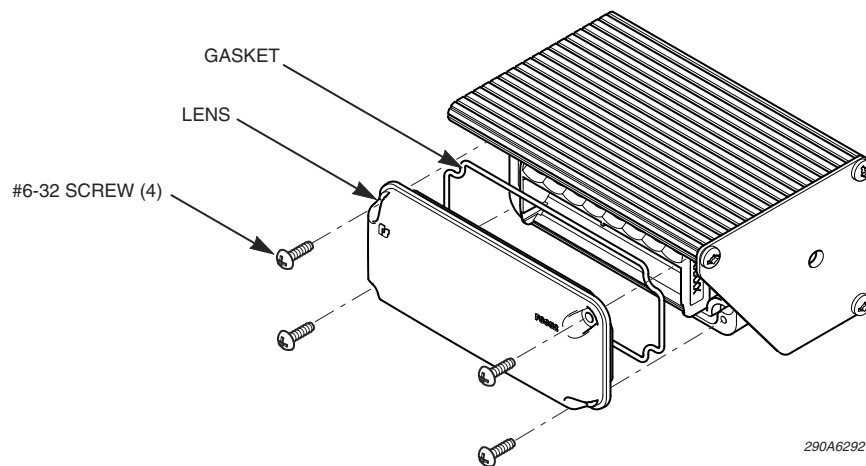

Figure 1: Viper SignalMaster lens removal

## Removing a Lighthead

1. Remove and retain the three #8-32 screws that secure the end cap to the extrusion.
2. Disconnect the two cable assemblies. (Skip this step for Model 320810-RB.)
3. Slide the faceplate out of the extrusion
4. Remove and retain the two screws that secure the damaged lighthead to the faceplate (Figure 2 on page 4).
5. Disconnect the wire harness connector from the cable assembly.

## Reinstalling a Lighthead

1. Install the replacement lighthead by securing it with two removed screws. Tightly tighten the screws so that there is no movement in that lighthead. (Ensure that the LED is facing the upright position.)
2. Reconnect the wire harness to the cable assembly.
3. Slide the faceplate into the extrusion. Ensure that the faceplate is captured by the tabs of the extrusion.
4. Reconnect the cable assemblies. (Skip this step for Model 320810-RB.)
5. Replace the end cap.

**NOTICE****DO NOT OVERTIGHTEN SCREWS**

To avoid damage to the PC boards, do not overtighten the screws.

- Secure the end cap with the three #8-32 screws.

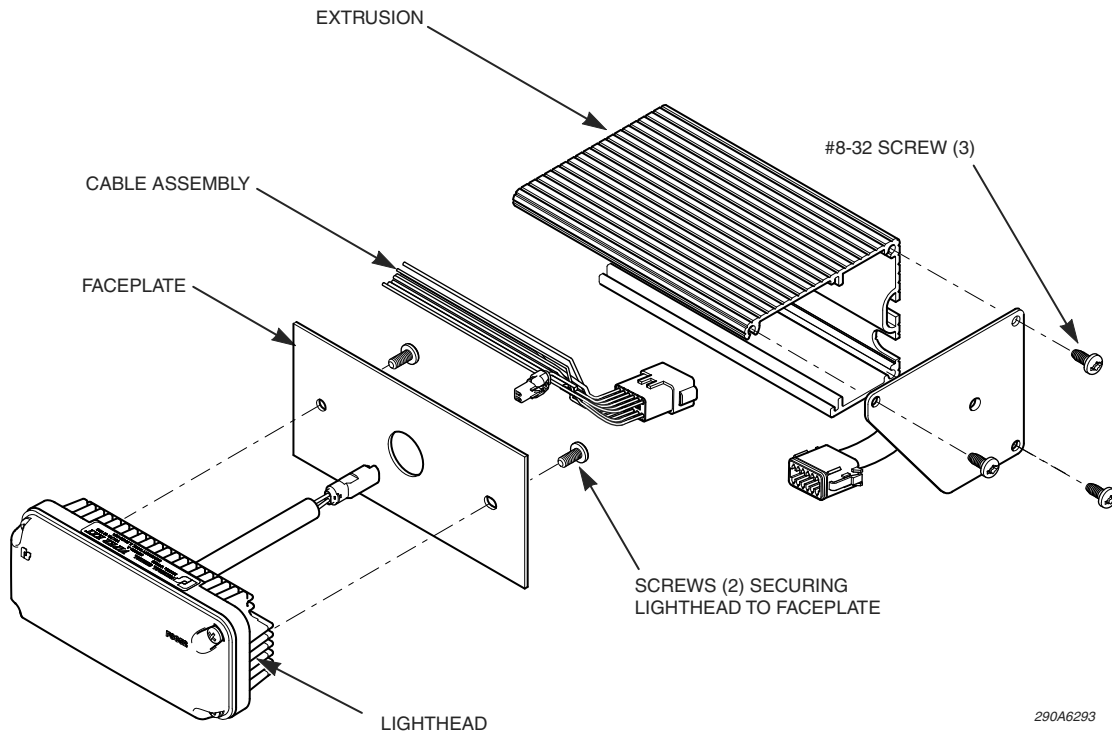

290A6293

Figure 2: Viper SignalMaster lighthouse removal

## Testing the System

### ⚠ WARNING

#### LIGHT HAZARDS

To be an effective warning device, this product produces bright light that can be hazardous to your eyesight when viewed at a close range. Do not stare directly into this lighting product at a close range or permanent damage to your eyesight may occur.

### ⚠ WARNING

#### SOUND HAZARD

All effective sirens and horns produce loud sounds (120 dB) that may cause permanent hearing loss. Always minimize your exposure to the sound of the siren or horn and wear hearing protection. Do not sound the siren or horn indoors or in enclosed areas where you and others will be exposed to the sound.

After the installation, test the emergency warning system to ensure that it is operating properly. Also test all vehicle functions, including horn operation, vehicle safety functions, and vehicle lighting systems to ensure proper operation. Ensure that the installation has not affected the vehicle operation or changed any vehicle safety functions or circuits. After testing is complete, provide a copy of these instructions to the instructional staff and all operating personnel.

Do not test the sound and light system of the vehicle while driving. Operating the vehicle warning systems may pose a hazard to the operator and other drivers if the systems do not function as expected. Test the vehicle only in a controlled environment.

## Cleaning the Plastic Lenses

### **⚠ WARNING**

#### **CRAZING/CLEANING SOLUTIONS**

**The use of cleaning solutions, such as strong detergents, solvents, and petroleum products, can cause crazing (cracking) of the plastic lenses and reflectors.**

**Failure to follow this warning can damage the lenses and reflectors, reducing their effectiveness, and may result in bodily injury or death to you or others.**

1. Rinse the lenses with lukewarm water to loosen dirt and debris.
2. Use a mild soap, lukewarm water, and a soft cloth to gently clean the lenses. To avoid damaging the lens, do not use heavy pressure or caustic, abrasive, or petroleum-based cleaners.
3. Rinse and dry the lenses with a soft cloth to prevent water spotting.
4. To remove fine scratches and haze, use a specialty plastic cleaner/polish and a soft cloth. You can also use a high quality automotive paste cleaner/wax that is non-abrasive.

The most effective product you can use for cleaning, protecting, and polishing clear and colored plastics is Plexus® Plastic Cleaner, Protectant & Polish. Over time, exposure to heat, sunlight, and smog causes plastic to fade, discolor, scratch, or become brittle. Plexus seals the pores of the plastic, making the plastic easier to clean, improving scratch resistance, and increasing product longevity.

## Getting Replacement Parts

To order replacement parts (Table 1), please contact:

Customer Support  
Federal Signal Corporation  
Phone: 1-800-264-3578

*Table 1: Replacement parts*

<b>Description</b>	<b>Part Number</b>
Amber Viper EXT	8613194-01
Blue Viper EXT	8613194-02
Red Viper EXT	8613194-03
Amber Viper EXT with Clear Lens	8613194-04
Blue Viper with Clear Lens	8613194-05
Red Viper with Clear Lens	8613194-06
Amber Lens Kit	8613191
Blue Lens Kit	8613191-01
Clear Lens Kit	8613191-02
Red Lens Kit	8613191-03
Amber Viper EXT, Title 13	8613194-09
Amber Viper EXT with Clear Lens, Title 13	8613194-10

## Getting Technical Support and Service

For technical support and service, please contact:

Service Department  
Federal Signal Corporation  
Phone: 1-800-433-9132  
Fax: 1-800-343-9706  
Email: empsserviceinfo@fedsig.com

## Returning a Product to Federal Signal

Before returning a product to Federal Signal, call 800-264-3578, 800-433-9132, or 800-824-0254 to obtain a Returned Merchandise Authorization number (RMA number). To expedite the process please be prepared with the following information:

- Your Federal Signal customer or account number.
- The purchase order number under which the items were purchased.
- The shipping method.
- The model or part number of the product being returned.
- The quantity of products being returned.
- Drop ship information as needed.
- Any estimate required.

When you receive your RMA Number:

- Write the RMA number on the outside of the box of returned items.
- Reference the RMA number on your paperwork inside of the box.
- Write the RMA number down, so that you can easily check on status of the returned equipment.

Send all material with the issued RMA Number to:

Federal Signal Corporation  
2645 Federal Signal Drive  
University Park, IL 60484-3167  
Attn: Service Department  
RMA: # \_\_\_\_\_



2645 Federal Signal Drive, University Park, IL 60484-3167  
Tel.: (800) 264-3578 • Fax: (800) 682-8022  
[www.fedsig.com](http://www.fedsig.com)

© 2009 Federal Signal Corporation