

256A768L Rev. LO 0817

Safety Message to Installers of Warning Equipment

▲ WARNING

The lives of people depend on your proper installation and servicing of Federal Signal products. It is important to read and follow all instructions shipped with the product. In addition, listed below are some other important safety instructions and precautions you should follow:

Before Installation

Qualifications

- To properly install a siren, you must have a good understanding of automotive electrical procedures and systems, along with proficiency in the installation and service of safety warning equipment. Always refer to the vehicle's service manuals when performing equipment installations on a vehicle.

Sound Hazards

- Your hearing and the hearing of others, in or close to your emergency vehicle, could be damaged by loud sounds. This can occur from short exposures to very loud sounds, or from longer exposures to moderately loud sounds. For hearing conservation guidance, refer to federal, state, or local recommendations. OSHA Standard 1910.95 offers guidance on "Permissible Noise Exposure."
- All effective sirens and horns produce loud sounds (120 dB) that may cause permanent hearing loss. Always minimize your exposure to siren sound and wear hearing protection. Do not sound the siren indoors or in enclosed areas where you and others will be exposed to the sound.

During Installation

- DO NOT get metal shavings inside the product. Metal shavings in the product can cause the system to fail. If drilling must be done near the unit, place an ESD approved cover over the unit to prevent metal shavings from entering the unit. Inspect the unit after mounting to be sure there are no shavings present in or near the unit.
- DO NOT connect this system to the vehicle battery until ALL other electrical connections are made, mounting of all components is complete, and you have verified that no shorts exist. If wiring is shorted to vehicle frame, high current conductors can cause hazardous sparks resulting in electrical fires or flying molten metal.
- Sound propagation and warning effectiveness will be severely reduced if the siren is not facing forward. Carefully follow the installation instructions and always install the siren with the grille facing forward.
- Install the siren as far forward on the vehicle as possible in a location that provides maximum signaling effectiveness and minimizes the sound reaching the vehicle's occupants. Refer to the National Institute of Justice guide 500-00 for further information.
- Mounting the sirens behind the grille will reduce the sound output and warning effectiveness of the siren system. Before mounting sirens behind the grille, make sure the vehicle operators are trained and understand that this type of installation is less effective for warning others.

Installation Instructions for the Q-Siren

- DO NOT install the siren(s) or route the siren wires where they may interfere with the operation of air bag sensors.
- Never attempt to install aftermarket equipment, which connects to the vehicle wiring, without reviewing a vehicle wiring diagram available from the vehicle manufacturer. Insure that your installation will not affect vehicle operation and safety functions or circuits. Always check vehicle for proper operation after installation.
- DO NOT install equipment or route wiring or cord in the deployment path of an airbag.
- When drilling into a vehicle structure, be sure that both sides of the surface are clear of anything that could be damaged.

After Installation

- After installation, test the siren system and the light system to ensure both are operating properly.
- Test all vehicle functions, including horn operation, vehicle safety functions and vehicle systems to ensure proper operation. Ensure that installation has not affected vehicle operation or changed any vehicle safety function or circuit.
- After testing is complete, provide a copy of these instructions to the instructional staff and all operating personnel.
- File these instructions in a safe place and refer to them when maintaining and/or reinstalling the product.

Failure to follow all safety precautions and instructions may result in property damage, serious injury, or death.

Unpacking the Siren

After unpacking the siren, inspect it for damage that may have occurred in transit. If it has been damaged, do not attempt to install or operate it. File a claim immediately with the carrier, stating the extent of damage. Carefully check all envelopes, shipping labels, and tags before removing or destroying them. Ensure that the parts in the Kit Contents List are included in the package. Disposal of all shipping materials must be carried out in accordance with national and local codes and standards. If you are missing any parts, contact Customer Support at 1-800-264-3578, 7 a.m. to 5 p.m., Monday through Friday (CT)

Table 1 Kit contents

Qty.	Description	Part Number
3	Lug, 90 A	224A237-03
1	Grommet	8108A002
1	Grommet	8108A005
1	Terminal	506A001
1	Terminal	224A202-07
3	Washer, Flat, 11/32, SS	7072A031
3	Bolt, 5/16 x 18, Hex-Head, SS	7002A005-24
3	Nut, 5/16-18, SS	7057A027
3	Lockwasher, 5/16, SS	7074A020

Mounting the Q-Siren

⚠ WARNING

DO NOT ALTER THE SIREN: Any attachment to the Q-Siren or other alteration of the product may reduce its ability to warn and may interfere with the ability of the Q-Siren to meet applicable industry standards. Federal Signal does not recommend or approve the use of any sound focusing device or other attachments to the Q-Siren. The unauthorized use of a sound focusing device or other attachment could result in serious injury or death.

Two mounting options are available for the Q-Siren: pedestal mounting (Model Q2B-012PSD) and flush mounting, (Model Q2B-012NNSD). Federal Signal recommends that flush mounting be done only done by the vehicle manufacturer.

Pedestal Mounting the Model Q2B-012PSD

The Model Q2B-012PSD is designed to be installed on a flat surface.

To mount the siren using the pedestal:

1. See Figure 1 on page 4 and Figure 5 on page 8. Select a suitable mounting location with sufficient clearance on the underside of mounting surface. Ensure that underside of the mounting surface is clear of any wires or brackets.

⚠ WARNING

DRILLING PRECAUTIONS: When drilling holes, check the area into which you are drilling to be sure that you do not damage vehicle components. All drilled holes should be deburred and all sharp edges should be smoothed.

2. Using the template on page 12, scribe five drill-position marks on the mounting surface (three mounting holes and two holes for the grommets).
3. Drill a 11/32 in hole at each mounting-hole position mark. Drill a 17/32 in hole at each mark scribed for the grommet holes.
4. Install the grommet with the large hole in the front 17/32 in hole and the grommet with the small hole in the rear 17/32 in hole.

5. To ensure a good vehicle ground, scrape off the paint around the mounting holes on both sides of the mounting surface.
6. Route the power (4 AWG) and brake (12 AWG) leads through the grommets and the holes in the mounting surface.

NOTICE

HEAVY OBJECT: Use lifting aids and proper lifting techniques when removing or replacing the siren. Failure to follow this warning may cause personal injury.

7. Position the siren base over the mounting holes. Insert three 5/16 in x 18 bolts through the holes in the pedestal mounting bosses and mounting surface.
8. Secure the siren with the flat washer, lockwasher and nut as shown in Figure 1.
9. Torque the mounting bolts to 110 in-lb to 130 in-lb.

Figure 1 Side view of pedestal mount

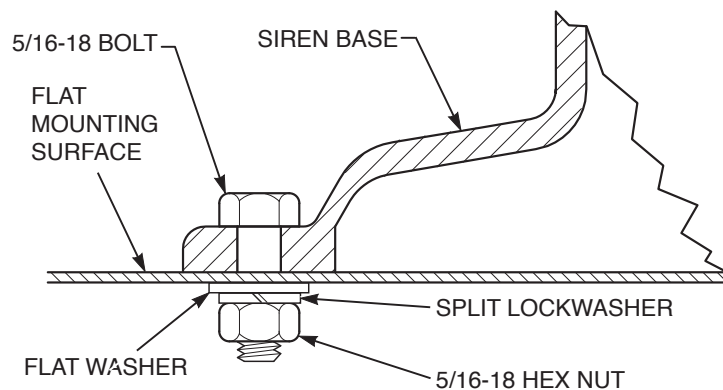

Flush Mounting the Model Q2B-012NNSD

Model Q2B-012NNSD is designed to be flush-mounted at the front of emergency vehicles. The mounting of this model should only be attempted by the emergency vehicle manufacturer; it is not recommended for local emergency vehicle service departments. Installation in the emergency vehicle should be in accordance with the specifications of each vehicle manufacturer.

To ensure the stability of the Q-Siren and help prevent water ingress, it is also recommended that the mount for the Q-Siren be installed by the manufacturer of the emergency vehicle. The mount must be designed to use both holes in the motor structure. The use of alternate mounting methods by the manufacturer of the emergency vehicle may void the warranty.

Bumper Mounting the Model Q2B-012NNSD

The Model Q2B-012NNSD can also be mounted in a bumper using the Model Q-MT bumper mounting kit. This mounting method should only be attempted by emergency vehicle manufacturers; it is not recommended for local emergency vehicle service departments. Installation in the emergency vehicle should be in accordance with the specifications of each vehicle manufacturer.

Table 1 Q-MT Kit contents

Qty.	Description	Part Number
2	Bolt, 5/16 in x 18, Hex Head	7002A004-12
2	Lockwasher, 5/16 in	7074A019
2	Washer, Flat.	7072A032
1	Bracket, Mounting	8280081

To mount the siren in the bumper:

- Using Figure 2 below and Figure 3 on page 6 as guides, determine the mounting location in the bumper. Ensure that there is adequate clearance behind the bumper.

Figure 2 Bumper cutout for Q-Siren

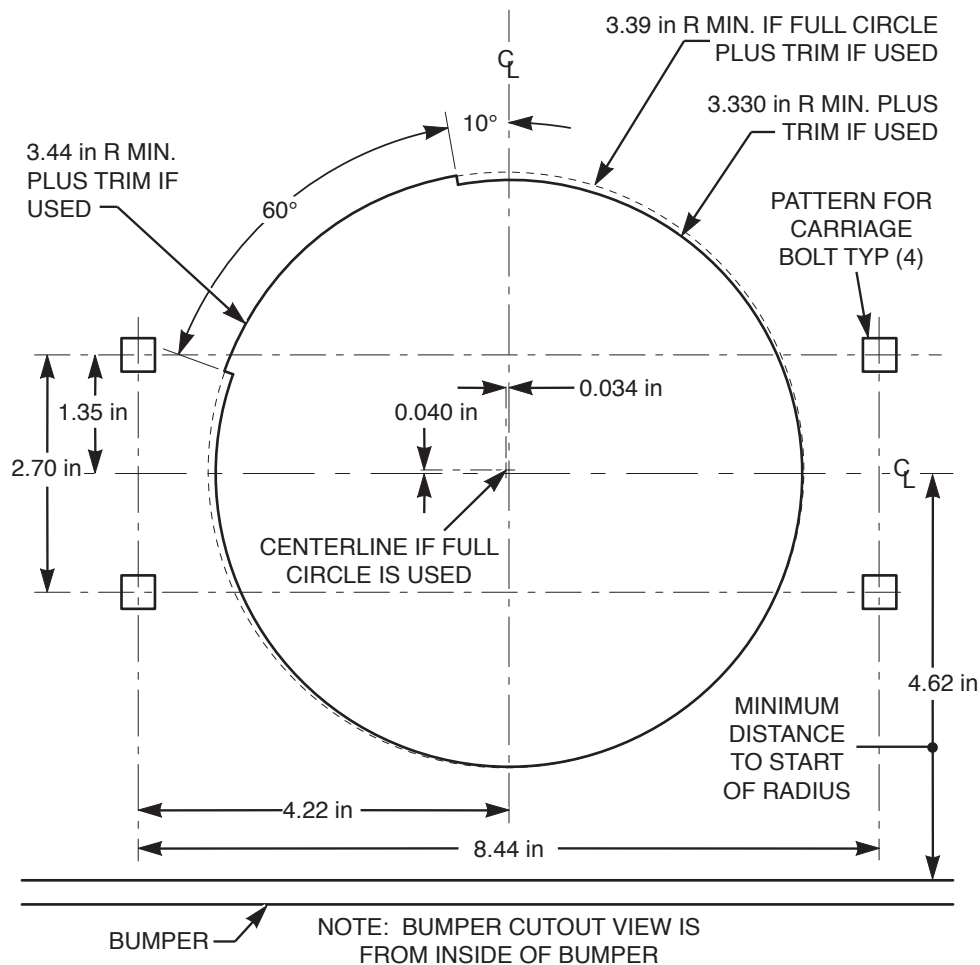

⚠ WARNING

CUTTING PRECAUTIONS: When cutting holes, check the area into which you are cutting to be sure that you do not damage vehicle components. All cut holes should be deburred and all sharp edges should be smoothed.

- Cut the hole pattern in the bumper as shown in Figure 2.

Installation Instructions for the Q-Siren

- Secure the mounting bracket to the bumper with user-supplied hardware as shown in Figure 3.

Figure 3 Mounting bracket viewed from inside of bumper

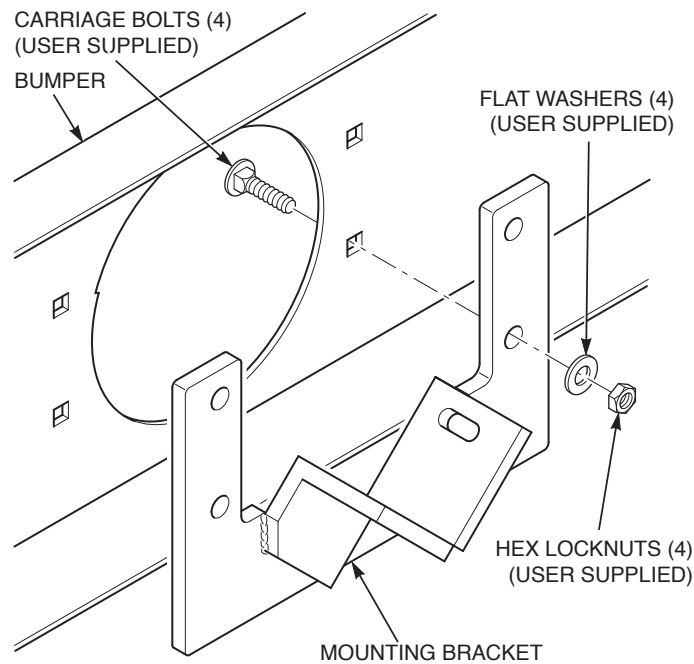

- See Figure 4 on page 7. Slide the siren into the bumper from the front.
- Apply Loctite 263 or equivalent to the supplied bolts.
- Secure the siren to the bracket using the supplied bolts, washers, and lockwashers.
- Torque the bolts to 110 in-lb – 130 in-lb.

Figure 4 Mounting bracket with siren installed

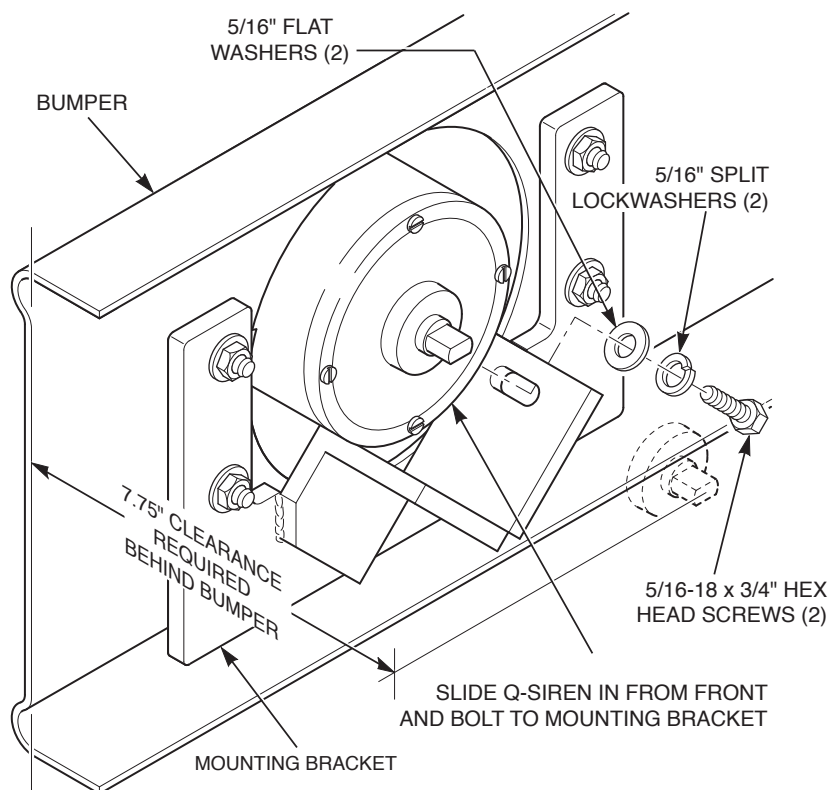

Installing the Brake Switch

⚠ WARNING

USE A MOMENTARY SWITCH ONLY: The brake is designed for use only with a momentary switch. Use of any other type of switch will result in premature failure of the brake solenoid. Failure to observe this warning may cause property damage, serious injury or death.

⚠ WARNING

SEAT REMOVAL PRECAUTION: If a vehicle seat is temporarily removed, verify with the vehicle manufacturer if the seat need needs to be recalibrated for proper airbag deployment. Failure to observe this warning may cause serious injury or death.

⚠ WARNING

AIRBAG DEPLOYMENT: Do not install equipment or route wiring in the deployment path of an airbag. Failure to observe this warning will reduce the effectiveness of the airbag or potentially dislodge the equipment, causing serious injury or death.

The Federal Signal Model Q2FSK, brake and foot switch kit is purchased separately.

See Figure 5 on page 8. Install the user-supplied momentary switch in a location that will allow both the vehicle and the controls to be operated safely in all driving conditions.

Installing the Foot Switch

Install the user-supplied foot switch (siren activation switch) on the vehicle floor in an area that will allow both the vehicle and the controls to be operated safely in all driving conditions.

Wiring the Siren

⚠ WARNING

GROUND THE SIREN PROPERLY: The siren will not function properly without a good vehicle ground. Ensure that the paint around the mounting holes on both sides of the mounting surface has been removed and that the mounting surface provides an effective ground path.

⚠ WARNING

ELECTRICAL FIRE HAZARD: If wires are shorted to the vehicle frame or each other, high current conductors can cause hazardous sparks resulting in electrical fires and molten metal. Verify that no short circuits exist before connecting to the positive (+) battery terminal.

⚠ WARNING

HIGH CURRENT ARCING: DO NOT connect this system to the vehicle battery until all other electrical connections are completed, mounting of all components is complete, and you have verified that no shorts exist. High current shorts can cause hazardous sparks or burning wire resulting in an electrical fire.

Make the electrical connections shown in Figure 5. Install user-supplied fuseholders and fuses (see the current ratings in Figure 5) as close as practical to the battery. Insulate all exposed connections with electrical tape.

Figure 5 Wiring for the EQ2B siren

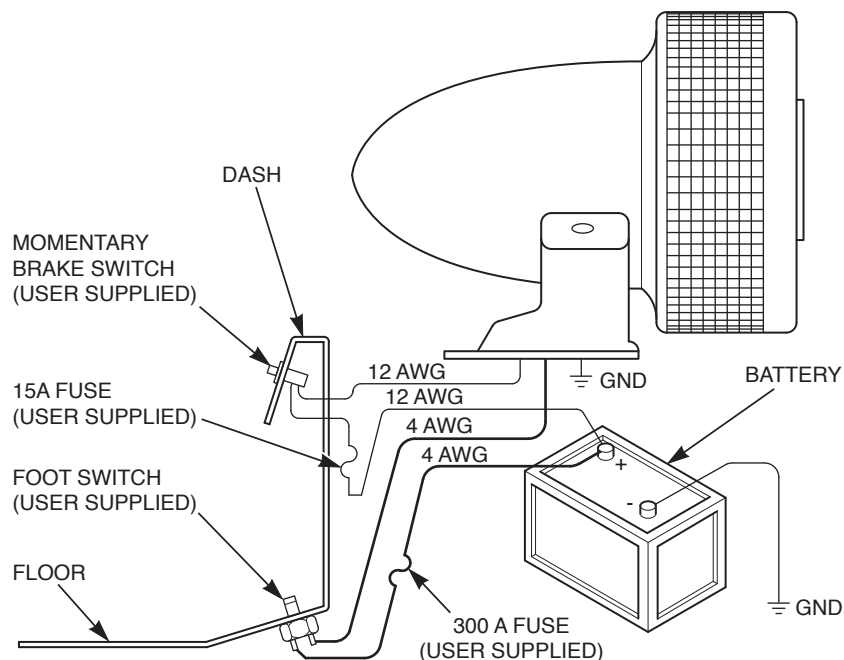

Testing the Siren

▲ WARNING

All effective sirens and horns produce loud sounds (120 dB) that may cause permanent hearing loss. Always minimize your exposure to siren sound and wear hearing protection. Do not sound the siren indoors or in enclosed areas where you and others will be exposed to the sound.

Refer to “Safety Messages to Operators” and test the siren system to ensure that it functions properly.

Safety Messages to Operators

▲ WARNING

The lives of people depend on your safe operation of Federal Signal products. It is important to read and follow all instructions shipped with the products. In addition, listed below are some other important safety instructions and precautions you should follow:

Qualifications

- To properly use an electronic siren and siren(s): you must have a good understanding of general vehicle operation, a high proficiency in the use of safety warning equipment, and thorough knowledge of state and federal UNIFORM TRAFFIC CODES.

Sound Hazards

- Your hearing and the hearing of others, in or close to your emergency vehicle, could be damaged by loud sounds. This can occur from short exposures to very loud sounds, or from longer exposures to moderately loud sounds. For hearing conservation guidance, refer to federal, state, or local recommendations. OSHA Standard 1910.95 offers guidance on “Permissible Noise Exposure.”
- All effective sirens and horns produce loud sounds (120 dB) that may cause permanent hearing loss. Always minimize your exposure to siren sound, roll up your windows and wear hearing protection. Do not sound the siren indoors or in enclosed areas where you and others will be exposed to the sound. Only use the siren for emergency response situations.

Sound Limitations

- Before using the vehicle, check to see if the siren is concealed from view. If the siren is not in clear view on the front of the vehicle, use extra caution when operating the vehicle. A concealed siren is less effective at warning others.
- Maximum sound output will be severely reduced if any objects are in front of the siren. If your installation has obstructions in front of the siren, drive even more cautiously.
- Frequently inspect the siren to ensure that it is clear of any obstruction, such as mud or snow, which will reduce maximum sound output.

Signaling Limitations

- Be aware that the use of your visual and audible signaling devices does not give you the right to force your way through traffic. Your emergency siren, and actions are REQUESTING the right-of-way.
- Although your warning system is operating properly, it may not alert everyone. People may not hear, see, or heed your warning signal. You must recognize this fact and continue driving cautiously.
- Situations may occur which obstruct your warning signal when natural or man-made objects are between your vehicle and others. This can also occur when you raise your hood or trunk lid. If these situations occur, be especially careful.

Driving Limitations

- At the start of your shift, you should ensure that the siren is securely attached to the vehicle and operating properly.
- If the unique combination of emergency vehicle equipment installed in your vehicle has resulted in the siren controls being installed in a position that does not allow you to operate them by touch only, OPERATE CONTROLS ONLY WHILE YOUR VEHICLE IS STOPPED.
- If driving conditions require your full attention, you should avoid operating the siren controls while the vehicle is in motion.

Continuing Education

- File these instructions in a safe place and refer to them periodically. Give a copy of these instructions to new recruits and trainees.

Failure to follow these safety precautions may result in property damage, serious injury, or death.

Operating the Siren

▲ WARNING

BRAKE FAILURE: Do not press the foot switch and the brake switch at the same time. Failure to follow this warning will cause the brakes to fail prematurely, causing serious injury or death.

NOTICE

DAMAGE TO THE BRAKE SOLENOID: Actuating the brake switch for more than 30 seconds can damage the brake solenoid. If it becomes necessary to stop the siren rapidly, depress the brake switch.

The siren is activated by depressing the foot switch. When the siren sound has peaked, release the foot switch and allow the siren to coast down. Before the siren stops, depress the foot switch again. This produces a wailing sound that provides maximum signalling effectiveness and optimum siren life.

Safety Messages to Service Personnel

▲ WARNING

The lives of people depend on your proper servicing of Federal Signal products. It is important to read and follow all instructions shipped with the products. In addition, listed below are some other safety instructions and precautions you should follow:

- Read and understand all instructions in this manual before servicing the electronic siren.
- To prevent the accidental activation of the siren, disconnect the the battery terminals before performing any maintenance.
- To properly service an electronic siren or siren, you must have a good understanding of automotive electrical procedures and systems, along with proficiency in the installation and service of safety warning equipment. Always refer to the vehicle service manuals when performing service on a vehicle.
- Electronic circuit and siren repairs must be performed by a qualified and competent electronic technician.
- Your hearing and the hearing of others, in or close to your emergency vehicle, could be damaged by loud sounds. This can occur from short exposures to very loud sounds, or from longer exposures to moderately loud sounds. For hearing conservation guidance, refer to federal, state, or local recommendations. OSHA Standard 1910.95 offers guidance on “Permissible Noise Exposure.”
- All effective sirens and horns produce loud sounds (120 dB) that may cause permanent hearing loss. Always minimize your exposure to siren sound and wear hearing protection. Do not sound the siren indoors or in enclosed areas where you and others will be exposed to the sound.
- DO NOT connect this system to the positive terminal of the battery until servicing is complete and you have verified that there are no short circuits to ground.
- For the siren to function properly, the ground connection must be made to the NEGATIVE battery terminal.
- After repair, test the electronic siren and siren system to ensure that it is operating properly.

Failure to follow all safety precautions and instructions may result in property damage, serious injury, or death.

When servicing the siren, ensure that the following hardware is torqued accordingly. Apply thread locker where noted in the table on page 13.

Figure 6 Mounting base template for the pedestal mount

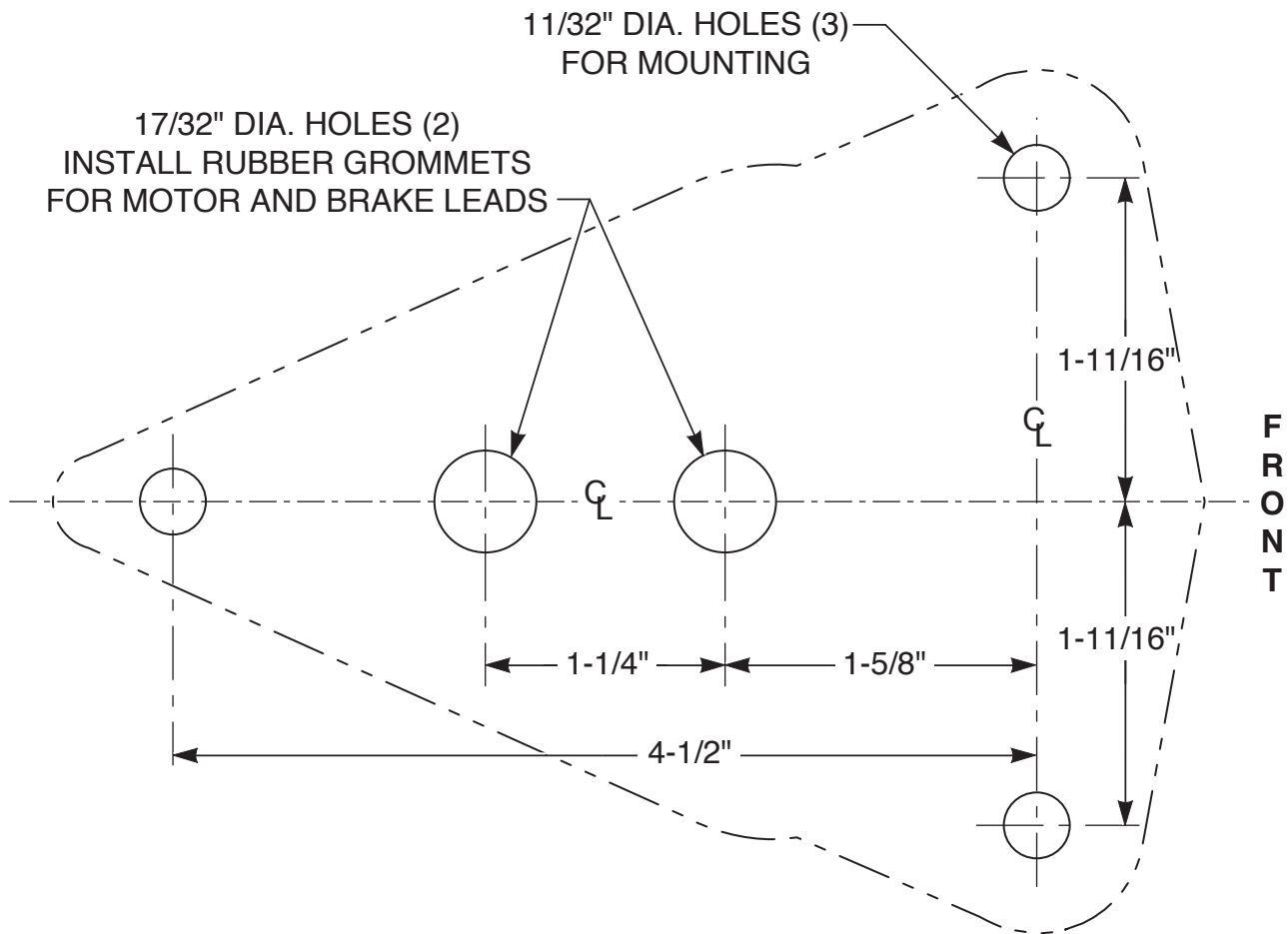

Maintaining the Siren

NOTICE

CLEANING AGENTS/CHROME DAMAGE: *The use of cleaning agents such as strong detergents, solvents, petroleum products, etc. can damage the chrome plated surfaces.*

Clean chrome plated parts using a mild soap and water solution and a soft rag. If fine scratches or a haze appear on the chrome, they can ordinarily be removed with a non-abrasive, high quality, one-step, automotive paste cleaner/wax and a soft cloth.

When servicing the siren, ensure that the following hardware is torqued as shown in Table 2 on page 13.

Table 2 Torque ranges for hardware

Description/location	Size	Torque Range	Notes
Dust cover screw	#6-32	7.0 to 8.5 in-lb	
Clutch mounting screw	#10-24	16 to 20 in-lb	Apply Loctite #271
Rotor lock nut	9/16-18	35 to 40 ft-lb	
Power Lug	5/16-18	110 to 130 in-lb	Hold lower nut when tightening
Stator mounting screw	#10-24	18 to 20 in-lb	Apply Loctite #277 or #271
Brake mounting screw	#10-32	18 to 20 in-lb	

Getting Technical Support and Service

The Federal Signal factory provides technical assistance with any problems that cannot be handled locally. Any units returned to Federal Signal for service, inspection, or repair must be accompanied by a Return Material Authorization (RMA). Obtain a RMA from a local Distributor or Manufacturer's Representative. Please provide a brief explanation of the service requested or the nature of the malfunction.

For technical support and service, visit:

<https://www.fedsig.com/technical-support>

<https://www.fedsig.com/service-centers>

Limited Warranty

This product is subject to and covered by a limited warranty, a copy of which can be found at www.fedsig.com/SSG-Warranty. A copy of this limited warranty can also be obtained by written request to Federal Signal Corporation, 2645 Federal Signal Drive, University Park, IL 60484, email to info@fedsig.com or call +1 708-534-3400.

This limited warranty is in lieu of all other warranties, express or implied, contractual or statutory, including, but not limited to the warranty of merchantability, warranty of fitness for a particular purpose and any warranty against failure of its essential purpose.



2645 Federal Signal Drive
University Park, Illinois 60484

www.fedsig.com

Customer Support

Police/Fire-EMS: 800-264-3578 • +1 708 534-3400

Work Truck: 800-824-0254 • +1 708 534-3400

Technical Support 800-433-9132 • +1 708 534-3400