

INSTRUCTION SHEET FOR SIGNALMASTER™ MODEL 331114

SAFETY MESSAGE TO INSTALLERS

People's lives depend on your safe installation of our products. It is important to read, understand and follow all instructions shipped with the products. In addition, listed below are some other important safety instructions and precautions you should follow:

- To properly install this light: you must have a good understanding of automotive electrical procedures and systems, along with proficiency in the installation and use of safety warning equipment.
- DO NOT install equipment or route wiring in the deployment path of an air bag.
- When drilling into a vehicle structure, be sure that both sides of the surface are clear of anything that could be damaged.
- In order for the light to function properly, a good ground connection must be made. At a minimum, it must be attached to a solid metal body or chassis part that will provide an effective ground path as long as the light system is to be used.
- Locate light control so the VEHICLE and CONTROL can be operated safely under all driving conditions.
- Do not attempt to activate or deactivate light control while driving in a hazardous situation.
- This product controls high intensity LED devices. To prevent eye damage, DO NOT stare into the light beam at close range.
- You should frequently inspect the light to ensure that it is operating properly and that it is securely attached to the vehicle.
- File these instructions in a safe place and refer to them when maintaining and/or reinstalling the product.

Failure to follow all safety precautions and instructions may result in property damage, serious injury, or death to you or others.

I. GENERAL.

The Federal Signal SignalMaster Model 331114 is an economical, low profile, solid state, directional light control that is designed to operate with Federal Signal's Model SML6-24V (six-lamp directional light assembly). The unit is reversed polarity protected to avoid damage if the positive and negative power connections are connected incorrectly.

This model provides three distinctive directional signals, left arrow, right arrow, and center out. An alternating flash pattern produces a warning signal for use when a directional signal may not be appropriate. In addition, an auxiliary flash pattern alternately flashes the external lamps. The directional and alternating flash patterns can also be selected to operate faster, or with decreased current draw. The slide switch overrides the WARN and AUX functions.

When normal directional signal operation is selected, the lamps individually activate sequentially in a sweeping motion until all six are illuminated. When LOW (current) operation is selected, the lamps turn on/off in sequence until a pattern is completed. When FAST is selected, the chosen pattern sequences at an increased rate.

An auxiliary input and output are provided for integrating external controls and lights into the SignalMaster system. When properly connected, a positive (+) 24 volts applied to the AUX IN terminal will activate the alternating flash pattern. The AUX OUT terminal can activate a ground-activated relay (user-supplied) when the AUX switch is operated.

WARNING

These lights are intended for **secondary** warning only. They are **not** intended for use as a primary warning system.

II. SPECIFICATIONS.

Input Voltage	21VDC to 28VDC.
Polarity	Negative ground only.
Operating Temperature Range	-30° C to +65° C.
Standby Current	Zero amperes.
+BAT Fuse	15 amperes.
+IGNITION Fuse	1 ampere.
AUX OUT Fuse	1 ampere.
Output Drive Capability (Total)	
Directional Auxiliary	6, 20 watt lamps. 4, 20 watt lamps (2 per output) or 2, 40 watt lamps (1 per output).
Normal Flash Rate:	
Directional	35 patterns/min.
Warn	60 patterns/min.
Auxiliary	95 patterns/min.
Fast Flash Rate:	
Directional	60 patterns/min.
Warn	95 patterns/min.
Auxiliary	95 patterns/min.
Dimensions:	
Height	1-1/2"
Width	6-1/8"
Depth	5"
Shipping Weight	2.5 lbs.

III. INSTALLATION.

WARNING

When installing equipment inside air bag equipped vehicles, the installer **MUST** ensure that the equipment is installed **ONLY** in areas recommended by the vehicle manufacturer.

Failure to observe this warning will reduce the effectiveness of the air bag, damage the air bag, or potentially damage or dislodge the equipment, causing serious injury or death to you or others.

A. SignalMaster Light Assembly.

Install the light assembly as described in the instructions packed with the 320340 universal mounting kit. Route the cable near the eventual location of the control unit.

B. *Control Unit.*

See figure 1. The supplied mounting bracket allows the control unit to be mounted in a variety of positions. To install the control unit, proceed as follows:

CAUTION

Install the control unit in an adequately ventilated area. Never install near heater ducts.

NOTE

When selecting a mounting location for the control unit, it is necessary to keep in mind that the SignalMaster cable is 15-feet long. Plan wiring and cable routing before installation.

1. Select a mounting location for the control unit that allows the vehicle and controls to be operated safely at all times.
2. Use the mounting bracket as a template and scribe two drill position marks at the selected mounting location.

CAUTION

Before drilling holes in ANY part of a vehicle, be sure that both sides of the mounting surface are clear of parts that could be damaged; such as brake lines, fuel lines, electrical wiring or other vital parts.

3. Drill two holes at the previously scribed position marks.
4. Secure the mounting bracket to the mounting surface with two user-supplied, thread-forming, 1/4-20 screws.

C. *Electrical Connections.*

WARNING

Failure to observe this WARNING may result in fire, burns or blindness.

If shorted to vehicle frame, high current conductors can cause hazardous sparks resulting in electrical fires or molten metal.

DO NOT connect this system to vehicle battery until ALL other electrical connections are made and mounting of all components is complete.

Verify that no short circuits exist, before connecting to the Positive (+) battery terminal.

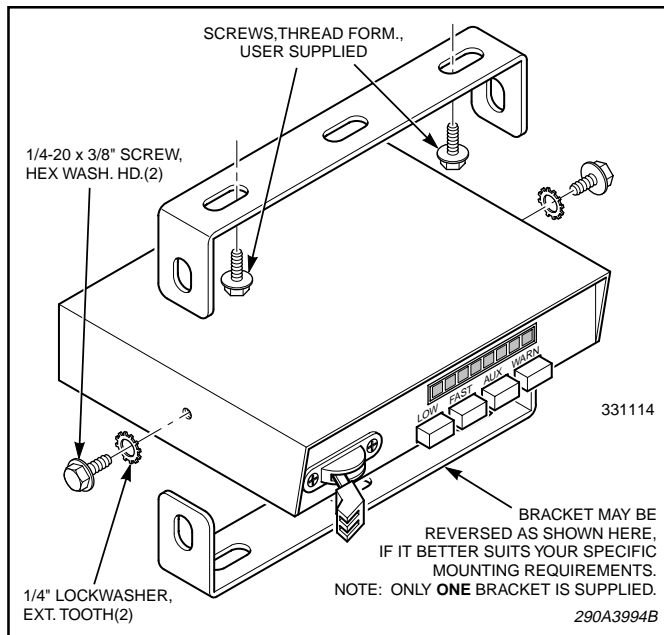

Figure 1.

The control unit is supplied with a seven-position connector, an eleven-position connector, and insulated spade connectors (0.250" (1) and 0.187" (2)) to perform the electrical installation. User-supplied, 14-gauge red and black wires are required for the (+) BAT and (-) GND connections. User-supplied, 18-gauge red and green wires are required for the (+) IGNITION and (-) CASE GROUND connections on the seven-position connector. In addition, user-supplied 18-gauge wire is used for the AUX IN, AUX OUT, and DASH LIGHTS connections. Using figure 2 as a guide, complete this portion of the installation as follows:

1. *Power Connections.*

CAUTION

To avoid damage and ensure proper operation, the red and black wires MUST be installed as shown in figure 2.

- a. Strip 1/4" of insulation off of each 14AWG red and black wire. See figure 2. Crimp a 0.187" wide spade receptacle on the red wire. Crimp the 0.250" wide spade receptacle on the black wire.
- b. Connect the red and black 14-gauge terminated wires to the +BAT and GND positions as shown in figure 2.
- c. Route the red and black 14-gauge wires through the firewall and toward the battery. Connect the black wire to a good frame ground near the battery. In most vehicles, a wire from the negative terminal of the battery is routed and attached to the body/frame at the fender. This is a convenient point to connect the 14-gauge black wire. Do not connect the red wire to the (+) positive terminal at this time.
- d. Connect the 18-gauge red (IGNITION) and green (CASE GROUND) wires to the connector as shown in figures 2 and 3.

IMPORTANT

The (+) IGNITION (18-gauge red) wire's termination point determines when the directional signal can be activated. When the wire is attached to a vehicle fuse that is powered when the ignition switch is in the run or start position, the vehicle's ignition switch must be in the run or start position to operate the directional signal. When the wire is attached to the vehicle battery, the directional signal can be operated at any time. Note that the unit draws no current when in the "off" position.

- e. Select the desired termination point. As applicable, route the 18-gauge red wire toward the vehicle fuse block or through the firewall toward the battery. Install a user-supplied, 1-ampere, in-line fuse in the 18-gauge red wire as close to the power source as possible and terminate as required.

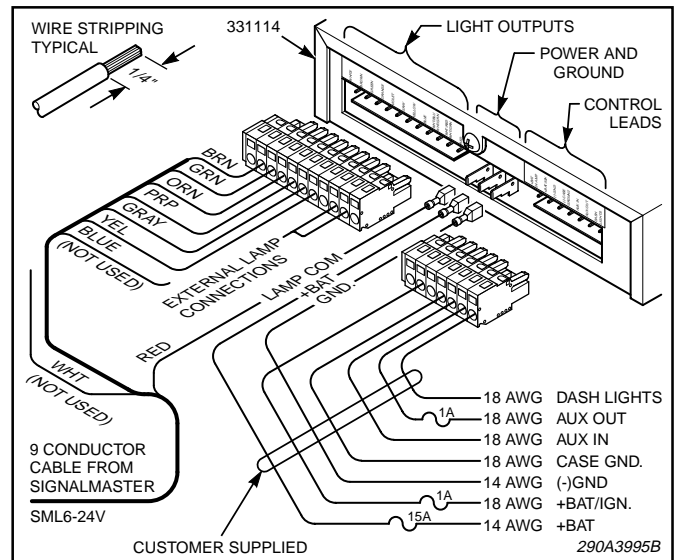

Figure 2.

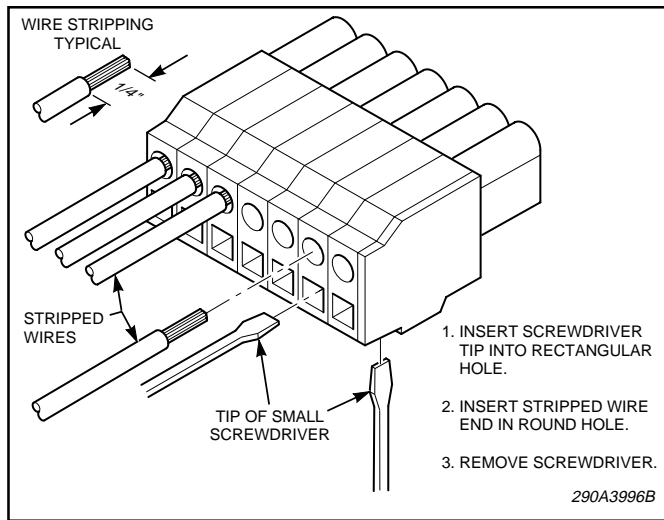

Figure 3.

f. Route the 18-gauge green wire to a known good chassis ground near the 331114 control. To provide a good ground connection, scrape any painted surface to bare metal.

2. AUX IN and AUX OUT Connections.

When a positive (+)24 volts is applied to the AUX IN connection, the alternating flash pattern is activated.

The AUX OUT connection will provide a ground to activate a ground-activated relay (user-supplied) when the AUX switch is operated. To perform the wiring for these connections, proceed as follows (see figures 2 and 3):

CAUTION

To avoid damage and ensure proper operation, the wires **MUST** be installed in the seven position connector as shown in figure 3.

a. Connect a user-supplied 18-gauge wire to the seven-position connector's AUX IN connection. Route the wire to a user-supplied external switch which will provide a positive (+) 24-volts (such as Federal Signal Model SW400SS) when activated.

b. Connect a user-supplied 18-gauge wire to the seven-position connector's AUX OUT connection. Route the wire to a user-supplied ground-activated relay for activation of an external device. Install an in-line, user-supplied, 1 ampere fuse between the control and the relay.

3. DASH LIGHTS Connection.

See figures 2 and 3. Connect a user-supplied 18-gauge wire to the seven-position connector's DASH LIGHTS connection. Route the wire to the vehicle instrument light circuit (if backlight dimming is required) or the accessory terminal of the ignition switch and terminate as required.

4. SignalMaster Cable Connections.

a. Route the SignalMaster cable towards the control unit, while being careful not to scrape the wires on any sharp edges.

b. If necessary, cut the cable to the appropriate length.

c. Connect the 22-gauge wires to the eleven-position connector as shown in figures 2 and 3. Positions 1 and 8 will not be used. Positions 9 and 10 are used for external lamp connections. Each of these two positions provides an alternating ground signal to activate external lamps. The maximum current draw for each position is 2-amperes.

d. Crimp a 0.187" wide spade receptacle on the SignalMaster cable red (lamp common) wire and connect it to the controller's LAMP COM (red) input.

D. Inspection and Final Installation.

1. Ensure that there are no loose wire strands or other bare wires which may cause a short circuit. Also, all wires must be protected from any sharp edges which could eventually cut through the insulation.

2. Plug the seven-position connector into the mating connector on the control unit, and apply pressure until it locks into place.

3. Plug the eleven-position connector into the mating connector on the control unit, and apply pressure until it locks into place.

4. Connect the remaining end of the 14-gauge red wire from the +BAT spade connector to the (+) positive terminal of the battery using an in-line, user-supplied fuseholder and 15A fuse. Locate the fuse as near the battery as possible to protect the entire length of wire.

5. Read and understand paragraph IV OPERATION. Test for proper operation of all functions.

6. Secure the mounting bracket to the control unit with the 1/4-20 hex head, thread forming screws and 1/4" external tooth lock washers (see figure 1).

IV. OPERATION.

SAFETY MESSAGE TO OPERATORS

Peoples' lives depend on your safe use of our products. Listed below are some important safety instructions and precautions you should follow:

- Although your warning system is operating properly, it may not be completely effective. People may not see or heed your warning signal. You must recognize this fact and continue driving cautiously.
- Also, situations may occur which obstruct your warning signal when natural or man-made objects are between your vehicle and others, such as: raising your hood or trunk lid. If these situations occur, be especially careful.
- This product controls high intensity LED devices. To prevent eye damage, DO NOT stare into the light beam at close range.
- At the start of your shift, you should ensure that the light is securely attached and all lamps are operating properly. The LED display on the control only simulates the operation of the lamps.
- If a selected function does not perform properly or if any of the lamps remain illuminated when the control is off, disconnect the power connector from the control unit and contact the nearest service center.

Failure to follow these safety precautions may result in property damage, serious injury, or death to you, to passengers, or to others.

RETAIN AND REFER TO THIS MESSAGE

See figure 4. All controls utilized during normal operation of the SignalMaster directional light are located on the front panel of the control unit. The LED display simulates the light pattern being executed by the directional light.

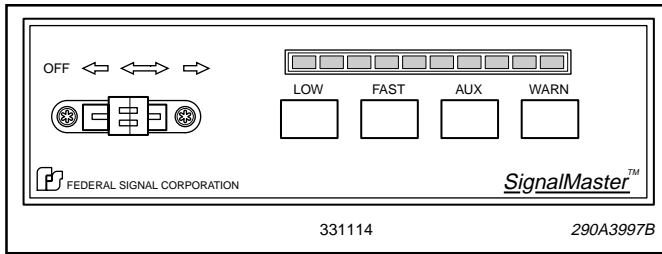

Figure 4.

A. *Slide Switch.*

1. LEFT (Position 1).

In this position, the light produces a left arrow flashing pattern, instructing traffic to move left.

2. CENTER OUT (Position 2).

In this position, a center out flashing pattern is produced, instructing traffic to move around either side of the vehicle.

3. RIGHT (Position 3).

In this position, the light produces a right arrow flashing pattern, instructing traffic to move right.

B. *WARN switch.*

When this switch is pressed, an alternating pattern is produced. The two middle lights activate alternately with the two outside lights on each side. The slide switch will override this pattern.

C. *AUX switch.*

1. When this switch is pressed, external lamps alternately flash at a constant rate. The wiring configuration determines the flash combination of the external lamps. The slide switch will override the external lamp pattern when the AUX switch is depressed, but will not override the AUX OUT terminal output.

2. If connected, the seven-position connector's AUX OUT connection provides a ground to activate a user-supplied relay to control an external device.

D. *FAST switch.*

When this switch is pressed, the flash rate of the selected directional or WARN pattern will increase. The rate of the AUX switch function is not affected.

E. *LOW switch.*

When this switch is pressed, all directional patterns are changed to turn lamps on/off in sequence until a pattern is completed. The last lamp activated in the pattern will flash three times. If this switch is operated while the WARN pattern is activated, the first and sixth lamp activate alternately with the third and fourth lamp. The selection of this function reduces the current draw for the directional light assembly's patterns. The AUX switch function is not affected by the LOW switch.

F. *Auxiliary Input.*

If connected, application of a positive (+) 24-volts to the AUX IN connection on the seven-position connector produces the WARN pattern described above. When the positive (+) 24-volts is removed from the AUX IN connection, the WARN pattern will stop. Slide switch activation will override the WARN pattern.

V. **SERVICE.**

A. *General.*

Servicing, other than cosmetic features, should be performed by a qualified Federal Signal service center. If the control unit is not working properly, disconnect all electrical connections starting with the power leads. Remove the control unit from the mounting bracket. Send the unit to the nearest authorized service center or the Federal Signal service department.

Communication and shipments should be addressed to:

Service Department
 Federal Signal Corporation
 2645 Federal Signal Drive
 University Park, IL 60466

1-800-433-9132

After servicing is complete, perform a test of all functions to ensure the control unit is operating properly.

B. *Replacement Parts List.*

Description	Part Number
Printed Circuit Board Assembly	2001142-03
Knob, Pushbutton	8573065
Knob, Slide Switch	8536C1041
Bezel, Slide Switch	8573060
Connector, Female, 7-position	140325-05
Connector, Female, 11-position	140325-09
Bracket, Mounting	8573070
Screw, Hex Head, Mounting	7011164-08
Lockwasher, 1/4"	7075078
Chassis	8573247
Cover	8573066