

INSTRUCTION SHEET FOR LED SIGNALMASTER™ MODEL 331122

SAFETY MESSAGE TO INSTALLERS

People's lives depend on your safe installation of our products. It is important to read, understand and follow all instructions shipped with the products. In addition, listed below are some other important safety instructions and precautions you should follow:

- To properly install this device; you must have a good understanding of automotive electrical procedures and systems, along with proficiency in the installation and use of safety warning equipment.
- DO NOT install equipment or route wiring in the deployment path of an air bag.
- When drilling into a vehicle structure, be sure that both sides of the surface are clear of anything that could be damaged.
- In order for the device to function properly, a good ground connection must be made. At a minimum, it must be attached to a solid metal body or chassis part that will provide an effective ground path as long as the light system is to be used.
- Locate light control so the VEHICLE and CONTROL can be operated safely under all driving conditions.
- Do not attempt to activate or deactivate light control while driving in a hazardous situation.
- This product controls high intensity LED devices. To prevent eye damage, DO NOT stare into the light beam at close range.
- You should frequently inspect the light to ensure that it is operating properly and that it is securely attached to the vehicle.
- File these instructions in a safe place and refer to them when maintaining and/or reinstalling the product.

Failure to follow all safety precautions and instructions may result in property damage, serious injury, or death to you or others.

I. GENERAL.

The Federal LED Signal SignalMaster Model 331122 is an economical, low profile, solid state, directional light control that is designed to operate with Federal Signal's LED SignalMaster series directional lights. The unit is reversed

polarity protected to avoid damage if the positive and negative power connections are connected incorrectly.

This controller was designed to work in conjunction with Model 320766 (6-module LED SignalMaster) and Model 320742 (4-module LED SignalMaster). The Model 331122 controller provides three distinctive directional signals for Model 320766: left arrow, right arrow, and center out. The three directional signals are selected with the slide switch. An additional flashing warn pattern is activated for Model 320766 by pushing the WARN pushbutton on the controller. However, the slide switch selection overrides the WARN function.

The controller's AUX pushbutton activates a flashing warn pattern on Model 320742 (4- module LED SignalMaster). The slide switch DOES NOT override the AUX pushbutton.

The controller also incorporates a turn signal override. When each of the turn signal override inputs is wired directly to their respective vehicle's flasher/relay input, a single end LED module (Model 320766 only) will flash in sync with the vehicle's turn signal. When installed, the turn signal override feature overrides any other function of Model 320766.

WARNING

These lights are intended for **secondary** warning only. They are **not** intended for use as a primary warning system.

II. SPECIFICATIONS.

Input Voltage	11VDC to 16VDC.
Polarity	Negative ground only.
Operating Temperature Range	-30° C to +65° C.
+BAT Fuse	10 amperes.
+IGN Fuse	1 ampere.
AUX OUT Fuse	1 ampere.
Dimensions:	
Height	1-1/2"
Width	6-1/8"
Depth	5"
Shipping Weight	2.5 lbs.

III. INSTALLATION.

A. *SignalMaster Light Assembly.*

Install the light assembly as described in the instructions packed with the LED SignalMaster mounting kit. Route the cable near the eventual location of the control unit.

B. *Control Unit.*

WARNING

When installing equipment inside air bag equipped vehicles, the installer **MUST** ensure that the equipment is installed **ONLY** in areas recommended by the vehicle manufacturer.

Failure to observe this warning will reduce the effectiveness of the air bag, damage the air bag, or potentially damage or dislodge the equipment, causing serious injury or death to you or others.

See figure 1. The supplied mounting bracket allows the control unit to be mounted in a variety of positions. To install the control unit, proceed as follows:

CAUTION

Install the control unit in an adequately ventilated area. Never install near heater ducts.

NOTE

When selecting a mounting location for the control unit, it is necessary to keep in mind the SignalMaster cable's length. Plan wiring and cable routing before installation.

1. Select a mounting location for the control unit that allows the vehicle and controls to be operated safely at all times.
2. Use the mounting bracket as a template and scribe two drill position marks at the selected mounting location.

CAUTION

Before drilling holes in ANY part of a vehicle, be sure that both sides of the mounting surface are clear of parts that could be damaged; such as brake lines, fuel lines, electrical wiring or other vital parts.

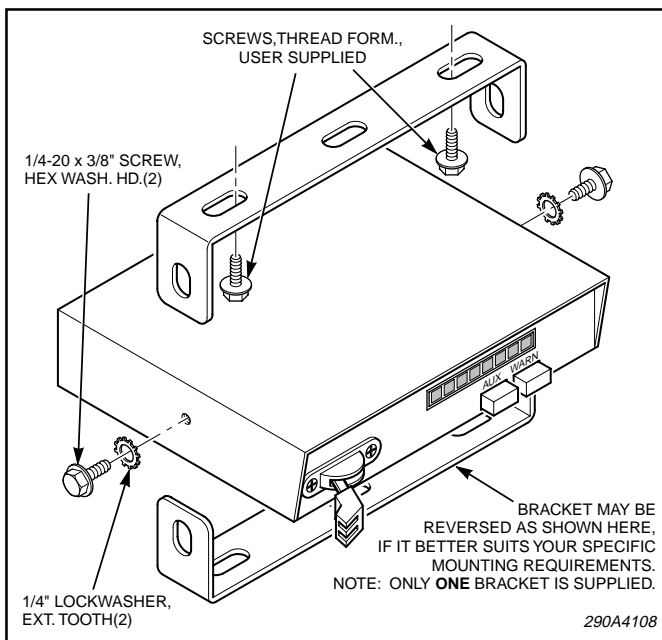

Figure 1.

3. Drill two holes at the previously scribed position marks.

4. Secure the mounting bracket to the mounting surface with two user-supplied, thread-forming, 1/4-20 screws.

C. *Electrical Connections.*

WARNING

Failure to observe this WARNING may result in fire, burns or blindness.

If shorted to vehicle frame, high current conductors can cause hazardous sparks resulting in electrical fires or molten metal.

DO NOT connect this system to vehicle battery until **ALL** other electrical connections are made and mounting of all components is complete.

Verify that no short circuits exist, before connecting to the Positive (+) battery terminal.

The control unit is supplied with a seven-position connector, an eleven-position connector, and insulated receptacles to perform the electrical installation. User-supplied, 14-gauge red and black wires are required for the (+) BAT and (-) GND connections. User-supplied, 18-gauge red and green wires are required for the (+) IGN and (-) CASE GROUND connections on the seven-position connector. In addition, user-supplied 18-gauge wire is used for the AUX IN, AUX OUT, TURN SIGNAL, and DASH LIGHTS connections. Using figure 2 as a guide, complete this portion of the installation as follows:

1. Power Connections.

CAUTION

To avoid damage and ensure proper operation, the red and black wires **MUST** be installed as shown in figure 2.

- a. Strip 1/4" of insulation off of each wire. See figure 2. Place the stripped end of each wire into the respective insulated receptacle (provided) and crimp.

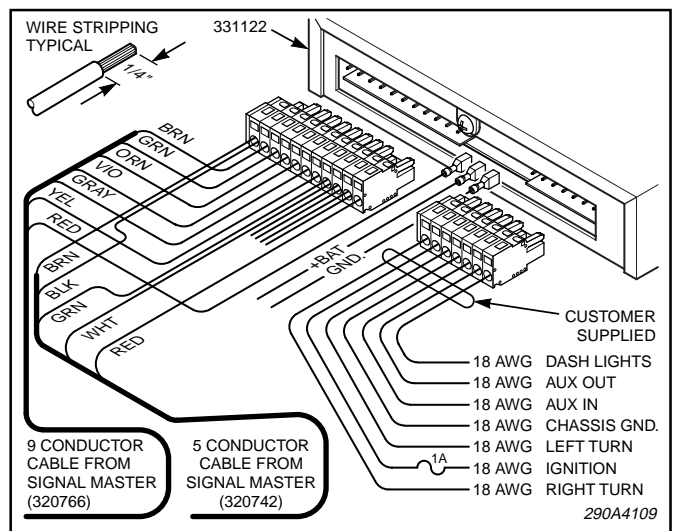

Figure 2.

b. Connect the red and black terminated wires to the tab terminals as shown in figure 2.

c. Route the red and black 14-gauge wires through the firewall and toward the battery. Connect the black wire to a good frame ground near the battery. In most vehicles, a wire from the negative terminal of the battery is routed and attached to the body/frame at the fender. This is a convenient point to connect the 14-gauge black wire. Do not connect the red wire to the (+) positive terminal at this time.

d. Connect the 18-gauge red (IGN) and green (CASE GROUND) wires to the connector as shown in figure 3.

IMPORTANT

The IGN (18-gauge red) wire's termination point determines when the directional signal can be activated. When the wire is attached to a vehicle fuse that is powered when the ignition switch is in the run or start position, the vehicle's ignition switch must be in the run or start position to operate the directional signal. When the wire is attached to the vehicle battery, the directional signal can be operated at any time.

e. Select the desired termination point. As applicable, route the 18-gauge red wire toward the vehicle fuse block or through the firewall toward the battery. Install a user-supplied, 1-ampere, in-line fuse in the 18-gauge red wire as close to the power source as possible and terminate as required.

f. Route the 18-gauge green wire to a known good chassis ground near the 331122 control. To provide a good ground connection, scrape any painted surface to bare metal.

CAUTION

To avoid damage and ensure proper operation, the wires **MUST** be installed in the seven-position connector as shown in figure 3.

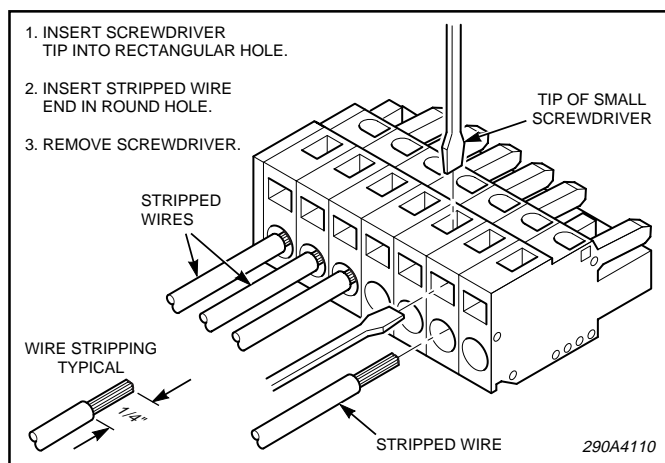

Figure 3.

2. DASH LIGHTS Connection.

See figures 2 and 3. Connect a user-supplied 18-gauge wire to the seven-position connector's DASH LIGHTS connection. Route the wire to the vehicle instrument light circuit (if backlight dimming is required) or the accessory terminal of the ignition switch and terminate as required.

3. SignalMaster Cable Connections.

a. Route both SignalMaster Cables towards the control unit. Avoid scraping the wires on any sharp edges.

b. If necessary, cut the cable to the appropriate length.

c. Connect both SignalMaster cable's 18 gauge wires to the eleven-position connector as shown in figure 2. Connect the 12 gauge red wire from the 320742 to the 11-position connector as shown in figure 2.

d. Strip 1/4" of insulation off of the 12 gauge red wire from the 320766. Place the stripped end of the wire into an insulated receptacle (provided) and crimp.

e. Connect the red terminated wire to the tab terminal as shown in figure 2.

4. Turn Signal Connection.

If installed, a single end LED module will flash in sync with the vehicle's turn signal. Each turn signal input must be wired directly to their respective vehicle's turn signal flasher/relay input.

D. Inspection and Final Installation.

1. Ensure that there are no loose wire strands or other bare wires which may cause a short circuit. Also, all wires must be protected from any sharp edges which could eventually cut through the insulation.

2. Plug the seven-position connector into the mating connector on the control unit, and apply pressure until it locks into place.

3. Plug the eleven-position connector into the mating connector on the control unit, and apply pressure until it locks into place.

4. Connect the remaining end of the 14-gauge red wire (power connection) to the (+) positive terminal of the battery using an in-line, user-supplied fuseholder and 10A fuse. Locate the fuse as near the battery as possible to protect the entire length of wire.

5. Read and understand paragraph IV OPERATION, and test for proper operation of all functions.

6. Secure the mounting bracket to the control unit with the 1/4-20 hex head, thread forming screws and 1/4" external tooth lock washers (see figure 1).

IV. OPERATION.

SAFETY MESSAGE TO OPERATORS

Peoples' lives depend on your safe use of our products. Listed below are some important safety instructions and precautions you should follow:

- Although your warning system is operating properly, it may not be completely effective. People may not see or heed your warning signal. You must recognize this fact and continue driving cautiously.
- Also, situations may occur which obstruct your warning signal when natural or man-made objects are between your vehicle and others, such as: raising your hood or trunk lid. If these situations occur, be especially careful.
- This product controls high intensity LED devices. To prevent eye damage, DO NOT stare into the light beam at close range.
- At the start of your shift, you should ensure that the light is securely attached and all lamps are operating properly. The LED display on the control only simulates the operation of the lamps.
- If a selected function does not perform properly or if any of the lamps remain illuminated when the control is off, disconnect the power connector from the control unit and contact the nearest service center.

Failure to follow these safety precautions may result in property damage, serious injury, or death to you, to passengers, or to others.

RETAIN AND REFER TO THIS MESSAGE

See figure 4. All controls utilized during normal operation of the SignalMaster directional light are located on the front panel of the control unit. The LED display simulates the light pattern being executed by the directional light.

A. Slide Switch.

1. LEFT (Position 1).

In this position, the light produces a left arrow flashing pattern, instructing traffic to move left.

2. CENTER OUT (Position 2).

In this position, a center out flashing pattern is produced, instructing traffic to move around either side of the vehicle.

3. RIGHT (Position 3).

In this position, the light produces a right arrow flashing pattern, instructing traffic to move right.

B. WARN switch.

When this switch is pressed, a flashing warn pattern on the Model 320766 (6-module LED SignalMaster) is produced. The slide switch will override this pattern.

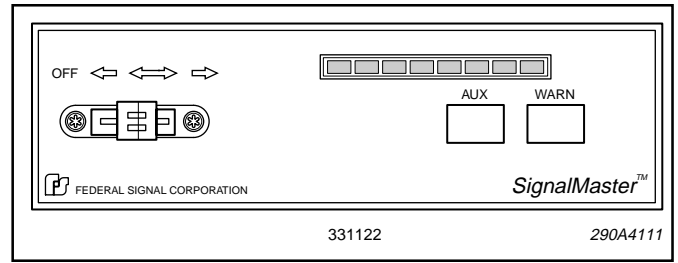

Figure 4.

C. AUX switch.

When this switch is pressed, a flashing warn pattern on the Model 320742 (4-module LED SignalMaster) is produced. The slide switch DOES NOT override the AUX pushbutton.

D. Turn Signal Inputs.

If connected, a single end LED module will flash in sync with the vehicle's turn signal. When installed, the turn signal override feature will override any other function of the Model 320766 (6-module LED SignalMaster).

V. SERVICE.

A. General.

Servicing, other than cosmetic features, should be performed by a qualified Federal Signal service center. If the control unit is not working properly, disconnect all electrical connections starting with the power connections. Remove the control unit from the mounting bracket. Send the unit to the nearest authorized service center or the Federal Signal service department.

Communication and shipments should be addressed to:

Service Department
Federal Signal Corporation
2645 Federal Signal Drive
University Park, IL 60466

1-800-433-9132

After servicing is complete, perform a test of all functions to ensure the control unit is operating properly.

B. Replacement Parts List.

Description	Part Number
Printed Circuit Board Assembly	2001142-04
Knob, Pushbutton	8573065
Knob, Slide Switch	8536C1041
Bezel, Slide Switch	8573060
Connector, Female, 7-position	140325-05
Connector, Female, 11-position	140325A-09
Bracket, Mounting	8573070
Screw, Hex Head, Mounting	7011164B-08
Lockwasher, 1/4"	7075078
Chassis	8573247
Cover	8573066
Insulated Receptacle, 3/16"	224A215-04
Insulated Rectptacle, 1/4"	224A216-04