

25500582 B0 1219

Safety Message to Installers and Operators of Warning Lights

▲ WARNING

People's lives depend on your proper installation and servicing of Federal Signal products. It is important to read and follow all instructions shipped with this product and the original product. Listed below are some other important safety instructions and precautions you should follow.

- To properly install the lighting system, you must have a good understanding of automotive systems, along with proficiency in the installation and use of safety warning equipment.
- Do not install equipment or route wiring in the deployment path of an airbag.
- If a vehicle seat is temporarily removed, verify with the vehicle manufacturer if the seat needs to be recalibrated for proper airbag deployment.
- Frequently inspect the light system to ensure that it is operating properly and that it is securely attached to the vehicle.
- When drilling into a vehicle structure, ensure that both sides of the surface are clear of anything that could be damaged. All drilled holes should be deburred and all sharp edges should be smoothed. All wires going through drilled holes should be protected by a grommet or convolute/split-loom tubing. Additionally, all exterior drilled holes must be sealed with Motorcraft® seam sealer T-A-2-B or equivalent to prevent the potential exposure to carbon monoxide or other potentially harmful fumes. Failure to observe this warning could cause serious injury or death.
- Do not stare directly into the lights at a close range, or permanent damage to your eyesight may occur.

Failure to follow all safety precautions and instructions may result in property damage, serious injury, or death.

Introduction

The MPSM6-FPIU20RS2 is a kit for mounting Federal Signal MicroPulse MPS6 Lightheads on a Ford 2020 Police Interceptor Utility vehicle.

Unpacking the Kit

After unpacking the product, inspect it for damage that may have occurred in transit. If it has been damaged or is missing a part, do not attempt to install or operate it. File a claim immediately with the carrier, stating the extent of the damage. Carefully check all envelopes, shipping labels and tags before removing or destroying them. Ensure that all parts in Table 1 have been included. If you are missing any parts, contact Customer Support at 1-800-264-3578, 7 A.M. to 5 P.M., Monday through Friday (CT).

Installing Six Spoiler-Mounted MicroPulse 6 Lightheads

Table 1 Kit Contents

Qty.	Description	Part Number
1	1.68 x 3.67 x 0.03 inch Gasket	2881407
6	Stainless Steel 1/4-inch Washer Head Hex Screw	7011183-12
6	8-32 Type TT Pan Head 6-Lobe Screw	70000143-06
1	Driver Side 3 HD Spoiler Bracket MP6-FPIU20RS2	861303100-DS
1	Passenger Side 3HD Spoiler Bracket MP6-FPIU20RS2	861303100-PS
1	Driver Side 3 HD Spoiler Cover FPIU MP6-FPIU20RS2	861303101-DS
1	Passenger Side 3 HD Spoiler Cover FPIU MP6-FPIU20RS2	861303101-PS
12	6-32 Stainless Steel Phillips Pan Head Machine Screw	7000491-08
12	6-32 Stainless Steel Keps Nuts	7058A46
6	1/4-inch Stainless Steel Lockwasher	7074A016
1	Grommet	228116

Precautions for Mounting the Brackets to the Spoiler

⚠ CAUTION

- When mounting brackets to the spoiler, use the provided dimensions in the installation instructions. When mounting the spoiler/bracket assembly, ensure that the spoiler sits flush against the vehicle liftgate.
- Ensure that the rear warning light harness does not double up or lay upon itself, preventing the rear spoiler from seating flush against the rear window of the liftgate. The rear warning light wiring harness must not prevent the rear spoiler/bracket assembly from sitting flush against the vehicle liftgate.
- After removal of the vehicle spoiler and prior to re-installation of the spoiler/bracket assembly, replace all spoiler seals with **FORD Liftgate Spoiler Kit**. This kit must be obtained from Ford Motor Company.
- Reference FORD Customer Satisfaction Programming 17B25 and SVE Bulletin P-027.
- All warning light wiring must be convolute/split loom or equivalent. Wiring entering or exiting the spoiler and vehicle must be grommeted and sealed with T-A-2-B Seam Sealer to prevent the potential exposure to carbon monoxide or other potentially harmful fumes.
- All warning light wiring must be tie wrapped and/or routed to prevent interference with other rear vehicle wiring or sealing.

⚠ WARNING

AIRBAG DEPLOYMENT: Do not install equipment or route wiring in the deployment path of an airbag. Failure to observe this warning will reduce the effectiveness of the airbag or potentially dislodge the equipment, causing serious injury or death.

Preparing the Mounting Area

To prepare the Ford Interceptor spoiler for the MPS6 lights:

1. Position the brackets as shown and mark the bracket locations on the spoiler with a grease pencil. Note that brackets and mounting are symmetric. See Figure 1.

Figure 1 Position of brackets

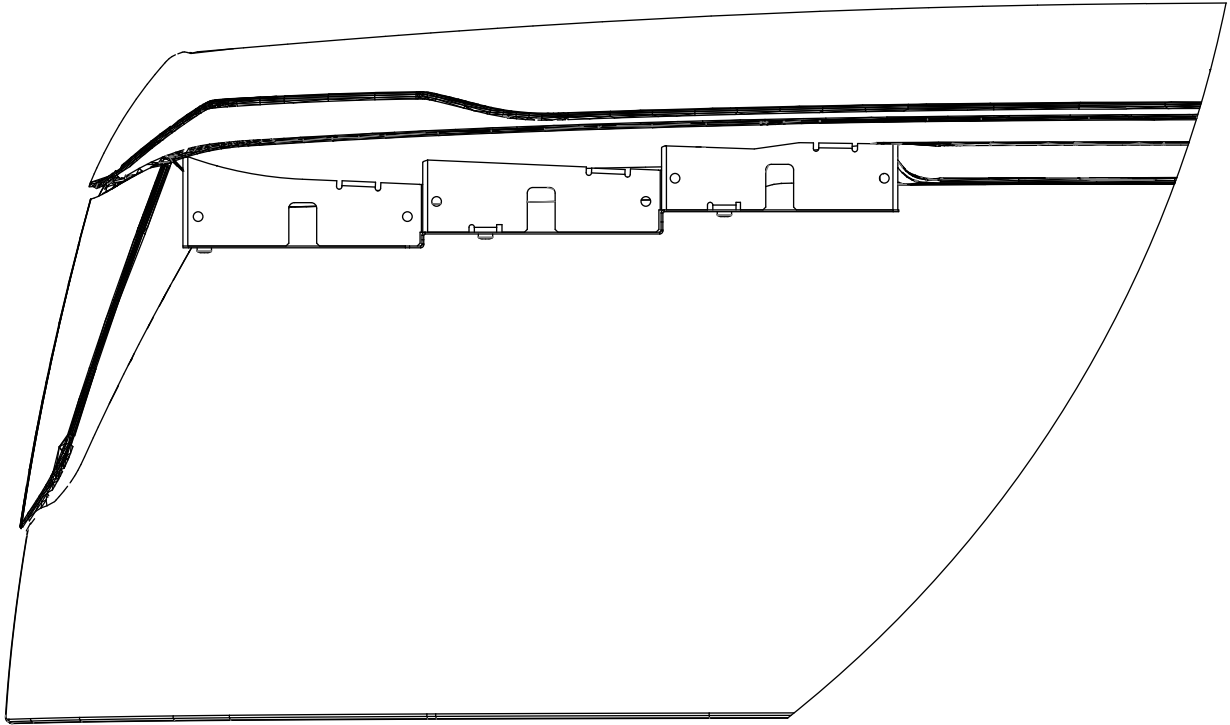

2. Following the vehicle manufacturer instructions, remove the rear spoiler assembly.
3. Position the brackets on the previously marked locations. Mark the mounting hole locations.

⚠ WARNING

DRILLING PRECAUTIONS: Before drilling holes, check the area into which you plan to drill to ensure that you do not damage vehicle components. All drilled holes should be deburred and all sharp edges should be smoothed. Additionally, all exterior drilled holes must be grommeted and sealed with Motorcraft seam sealer T-A-2-B or equivalent to prevent the potential exposure to carbon monoxide or other potentially harmful fumes. Failure to observe this warning could cause serious injury or death.

4. Using a 3/16-inch drill bit, drill the mounting holes through the outer layers (approximately 1/4-inch deep).
5. Drill the appropriate wire routing holes in the spoiler.
6. Drill an 11/16-inch wire routing hole in the tailgate.

Installing Six Spoiler-Mounted MicroPulse 6 Lightheads

7. Mount the brackets with 1/4-inch hex-head screws and 1/4-inch lockwashers. Do not overtighten.
8. Install the lightheads (not included) to both brackets with the supplied 6-32 screws and KEPS® nuts.
9. Complete the wiring according to the instructions supplied with the lightheads. Using the supplied grommet, route the wires through the hole drilled in Step 5 and the flex joint into the cabin. DO NOT route wires through any existing holes. A disconnect appropriate for the wiring may make spoiler installation easier. Seal the grommet and all openings made during the installation with the sealer noted above.
10. Install the cover plates with the black 8-32 thread-forming screws. See Figure 2.

Figure 2 Install the cover plates

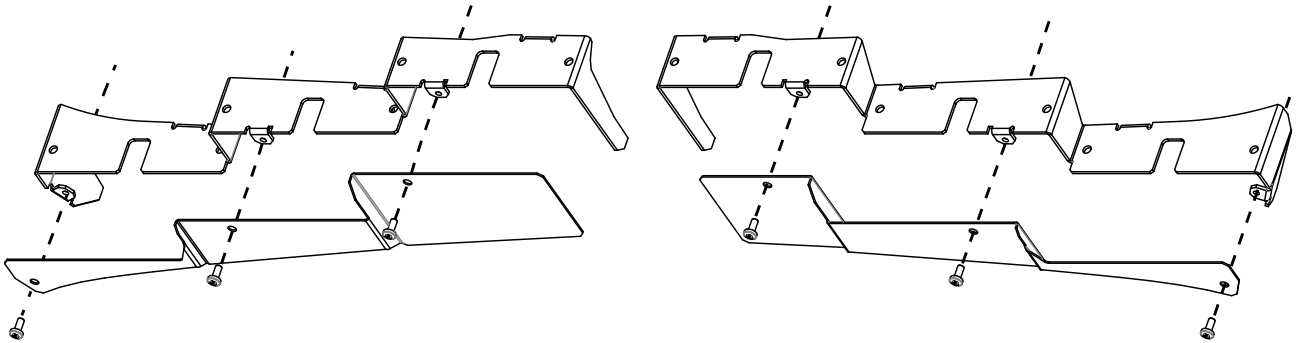

11. Cut the supplied gasket into four equal pieces (Figure 3) and mount to the back glass (Figure 4).

Figure 3 Gasket cut into four equal pieces

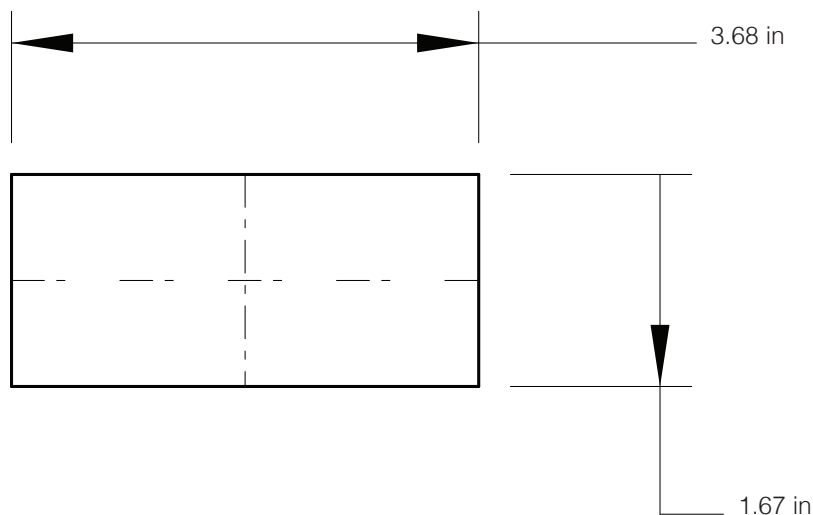
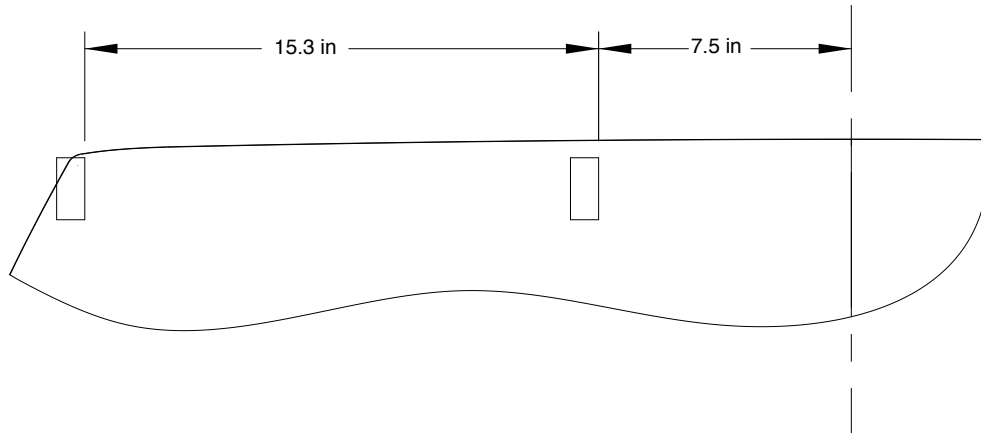

Figure 4 Mount gasket to the back glass



- 12.** Install the Ford Liftgate Spoiler Kit. You can obtain this kit from Ford Motor Company.
- 13.** Reinstall the spoiler per the vehicle manufacturer instructions. Ensure that the spoiler/bracket assembly sits flush against the vehicle liftgate.
- 14.** Test the lights for proper operation.

⚠ WARNING

LIGHT HAZARD: To be an effective warning device, an emergency warning system produces bright light that can be hazardous to your eyesight when viewed at close range. Do not stare directly into the lights at a close range or permanent damage to your eyesight may occur.

Getting Technical Support and Service

Installing Six Spoiler-Mounted MicroPulse 6 Lightheads

For technical support, please contact:

Federal Signal Corporation
Service Department
Phone: 1-800-433-9132
Email: empserviceinfo@fedsig.com

Getting Repair Service

The Federal Signal factory provides technical assistance with any problems that cannot be handled locally. Any product returned to Federal Signal for service, inspection, or repair must be accompanied by a Return Material Authorization (RMA). Obtain a RMA from a local Distributor or Manufacturer's Representative. Provide a brief explanation of the service requested, or the nature of the malfunction.

Address all communications and shipments to the following:

Federal Signal Corporation
Service Department
2645 Federal Signal Dr.
University Park, IL 60484-3167

Limited Warranty

This product is subject to and covered by a limited warranty, a copy of which can be found at www.fedsig.com/SSG-Warranty. A copy of this limited warranty can also be obtained by written request to Federal Signal Corporation, 2645 Federal Signal Drive, University Park, IL 60484, email to info@fedsig.com or call +1 708-534-3400.

This limited warranty is in lieu of all other warranties, express or implied, contractual or statutory, including, but not limited to the warranty of merchantability, warranty of fitness for a particular purpose and any warranty against failure of its essential purpose.



FEDERAL SIGNAL
Safety and Security Systems

2645 Federal Signal Drive
University Park, Illinois 60484

www.fedsig.com

Customer Support

Police/Fire-EMS: 800-264-3578 • +1 708 534-3400

Work Truck: 800-824-0254 • +1 708 534-3400

Technical Support 800-433-9132 • +1 708 534-3400

*All product names or trademarks are properties of their respective owners.
© 2019 Federal Signal Corporation*