

25500584 Rev. B0 0520

Safety Message to Installers of Warning Light Equipment

⚠ WARNING

People's lives depend on your proper installation and servicing of Federal Signal products. It is important to read and follow all instructions shipped with this product and the original product. Listed below are some other important safety instructions and precautions you should follow:

- To properly install a light assembly, you must have a good understanding of automotive electrical procedures and systems, along with proficiency in the installation and use of safety warning equipment.
- Do not install equipment or route wiring in the deployment path of an airbag.
- If a vehicle seat is temporarily removed, verify with the vehicle manufacturer if the seat needs to be recalibrated for proper airbag deployment.
- When drilling into a vehicle structure, be sure that both sides of the surface are clear of anything that could be damaged.
- To be an effective warning device, this product produces bright light that can be hazardous to your eyesight when viewed at close range. Do not stare directly into this lighting product at close range or permanent damage to your eyesight may occur.
- You should frequently inspect the light system to ensure that it is operating properly and that it is securely attached to the vehicle.
- Refer to the instruction sheets included with related products for additional precautions and information.
- File these instructions in a safe place and refer to them when maintaining or reinstalling the product.

Failure to follow all safety precautions and instructions may result in property damage, serious injury, or death.

Overview

IMPORTANT: This kit is designed for vehicles with the grille shown in Figure 1.

This publication has instructions for using the IPX-GRL16 Grille Mounting Kit to mount the Impaxx 600, MicroPulse™ 3 and MicroPulse 6 light heads behind the grille of the Ford® Interceptor Utility. For electrical installation instructions, refer to the Installation and Maintenance Instructions packed with the light head.

NOTE: User-supplied disconnects may be required on the wiring to ease assembly.

Unpacking the Kit

After unpacking the kit, inspect it for damage that may have occurred in transit. If it has been damaged, do not attempt to install or operate it. File a claim immediately with the carrier, stating the extent of damage. Carefully check all envelopes, shipping labels, and tags before removing or destroying them. Ensure that the parts listed in Table 1 on page 2 are included in the package. If you are missing any parts, contact Customer Support at 1-800-264-3578, 7 a.m. to 5 p.m., Monday through Friday (CT). Disposal of all shipping materials must be carried out in accordance with national and local codes and standards.

Table 1 Kit contents

Qty.	Description	Part Number
1	20FPIU MicroPulse Grille Bracket	861303076
4	#6-32 Phillips Pan Head Stainless Steel Screw	7000491-08
4	#6-32 Stainless Steel KEPS® Nut	7058A046
4	0.344X3/4X,0.050 Flat Stainless Steel Washer	7072A031
2	5/16"-18 Hex Head Bolt Cap 18-8	7002A005-24
2	5/16"-18 Stainless Steel Double Cham Nut	7057A027

Installing the Lights

IMPORTANT: Plan all cable routing before installation.

⚠ WARNING

AIRBAG DEPLOYMENT: Do not install equipment or route wiring in the deployment path of an airbag. Failure to observe this warning will reduce the effectiveness of the airbag or potentially dislodge the equipment, causing serious injury or death.

NOTICE

DRILLING PRECAUTIONS : Before drilling holes, check the area into which you plan to drill to ensure you do not damage vehicle components. All drilled holes should be deburred and all sharp edges should be smoothed. All wires going through drilled holes should be protected by a grommet or convolute/split-loom tubing.

To install the light heads:

1. Disassemble the front of the vehicle per the manufacturer’s service manual to access the area behind the grille.
2. Attach the light heads to the bracket:
 - For the IPX/MPS600, use the hardware supplied with the light head
 - For all other models, use the included 6-32 screws and KEPS nuts
3. Line up the bracket/light head assembly with the holes in the vehicle shown in Figure 1.

Figure 1 Ford Interceptor Utility grille



4. Install the bracket to the vehicle using the 5/16-inch bolts, washers, and nuts.

5. Tighten the mounting hardware. Do not over-tighten. See Figure 2 for exploded view.

Figure 2 Exploded view of bracket assembly

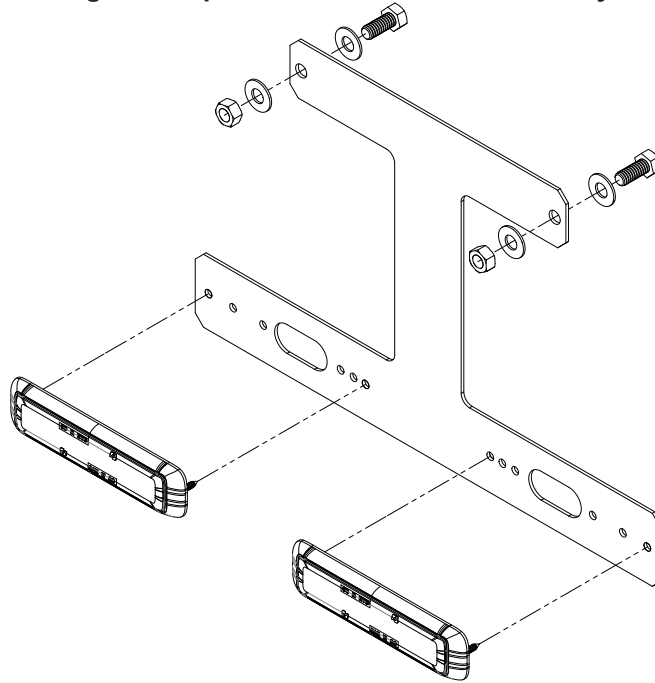

6. Complete the wiring according to the instructions supplied with the light head.
7. Reassemble the vehicle according to the manufacturer's service manual.

⚠ WARNING

LIGHT HAZARD: To be an effective warning device, an emergency warning system produces bright light that can be hazardous to your eyesight when viewed at close range. Do not stare directly into the lights at a close range or permanent damage to your eyesight may occur.

8. Test the lights for proper operation.

Getting Technical Support and Service

For technical support and service, please contact:

Service Department
Federal Signal Corporation
Phone: 1-800-433-9132
Email: emp-service-info@fedsig.com

Getting Repair Service

The Federal Signal factory provides technical assistance with any problems that cannot be handled locally.

Any units returned to Federal Signal for service, inspection, or repair must be accompanied by a Return Material Authorization (RMA). Obtain a RMA from a local Distributor or Manufacturer's Representative.

Provide a brief explanation of the service requested, or the nature of the malfunction.

Address all communications and shipments to the following:

Federal Signal Corporation
Service Department
2645 Federal Signal Drive
University Park, IL 60484-3167

Ordering Replacement Parts

To order replacement parts, call Customer Support at 1-800-264-3578, 7 a.m. to 5 p.m., Monday through Friday (CT) or contact your nearest distributor.

Limited Warranty

This product is subject to and covered by a limited warranty, a copy of which can be found at www.fedsig.com/SSG-Warranty. A copy of this limited warranty can also be obtained by written request to Federal Signal Corporation, 2645 Federal Signal Drive, University Park, IL 60484, email to info@fedsig.com or call +1 708-534-3400.

This limited warranty is in lieu of all other warranties, express or implied, contractual or statutory, including, but not limited to the warranty of merchantability, warranty of fitness for a particular purpose and any warranty against failure of its essential purpose.



FEDERAL SIGNAL
Safety and Security Systems

2645 Federal Signal Drive
University Park, Illinois 60484-3167

www.fedsig.com

Customer Support

Police/Fire-EMS: 800-264-3578 • +1 708 534-3400

Work Truck: 800-824-0254 • +1 708 534-3400

Technical Support: 800-433-9132 • +1 708 534-3400

© Copyright 2019 - 2020 Federal Signal Corporation

All product names or trademarks are properties of their respective owners.