

25500482 REV. A0 0718

Installing Interface Cable

This publication has instructions for installing the Dodge Charger Vehicle Interface Cable.

To install the interface cable:

1. Locate the Pigtail harness that plugs into the VSIM 24-way C2 Connector (see the Up-Fitters Guide for the vehicle for more information). The VSIM connectors are located under the center console, near the bottom of the instrument panel.
2. Make the following solder or crimp connections between the 24-way C2 Pigtail harness and the Federal Signal 17501771 cable. Make connections using cavity numbers, since wire colors may vary.

Table 1 Connections

Dodge 24-way C2 Pigtail harness		Federal Signal 17501771		
Cavity	Color	Cavity	Color	Function
11	BR/DG	1	White	CAN bus (+)
12	BR/LG	3	Green	CAN bus (-)
16	BK	2	Brown	GND (Shield)

Figure 1 Cable 17501771 Pinouts

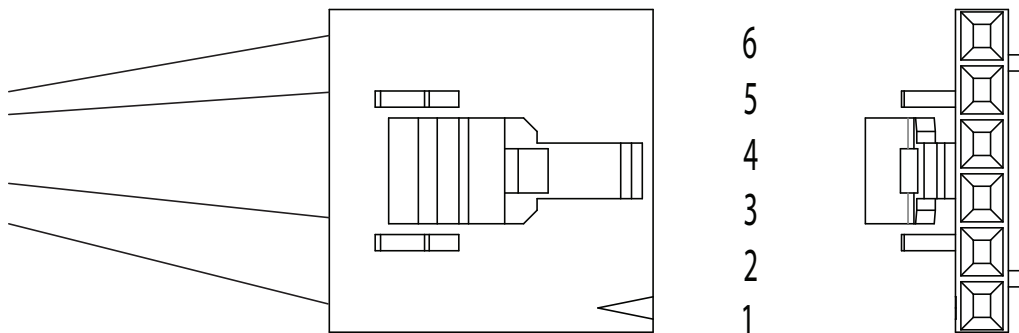

Connecting FS Vehicle Integration

To connect the Federal Signal vehicle integration:

1. Plug the VSIM 24-way C2 Connector harness into the vehicle.
2. Plug the 6 PIN cable (17501771) into the Pathfinder Siren. Refer to the Pathfinder instructions 25500463.

Programming FS Vehicle Integration

All programming is done using the Convergence Configuration Software. You will need to know the model year of the vehicle. Signals and vehicle events may vary by model year.

Getting Technical Support

For technical support, please contact:

Federal Signal Corporation

Service Department

Phone: 1-800-433-9132

Fax: 1-800-343-9706

Email: empserviceinfo@fedsig.com

Getting Repair Service

The Federal Signal factory provides technical assistance with any problems that cannot be handled locally.

Any units returned to Federal Signal for service, inspection, or repair must be accompanied by a Return Material Authorization (RMA). Obtain a RMA from a local Distributor or Manufacturer's Representative.

Provide a brief explanation of the service requested, or the nature of the malfunction.

Address all communications and shipments to the following:

Federal Signal Corporation

Service Department

2645 Federal Signal Drive

University Park, IL 60484-3167

Ordering Replacement Parts

To order replacement parts, call Customer Support at 1-800-264-3578, 7 a.m. to 5 p.m., Monday through Friday (CT) or contact your nearest distributor.