



**FEDERAL SIGNAL**  
Safety and Security Systems

# LED Beacon

---

## *Installation and Maintenance Instructions*

## Limited Warranty

This product is subject to and covered by a limited warranty, a copy of which can be found at [www.fedsig.com/SSG-Warranty](http://www.fedsig.com/SSG-Warranty). A copy of this limited warranty can also be obtained by written request to Federal Signal Corporation, 2645 Federal Signal Drive, University Park, IL 60484, email to [info@fedsig.com](mailto:info@fedsig.com) or call +1 708-534-3400.

This limited warranty is in lieu of all other warranties, express or implied, contractual or statutory, including, but not limited to the warranty of merchantability, warranty of fitness for a particular purpose and any warranty against failure of its essential purpose.



## FEDERAL SIGNAL

Safety and Security Systems

2645 Federal Signal Drive  
University Park, Illinois 60484

[www.fedsig.com](http://www.fedsig.com)

Customer Support

Police/Fire-EMS: 800-264-3578 • +1 708 534-3400

Work Truck: 800-824-0254 • +1 708 534-3400

Technical Support 800-433-9132 • +1 708 534-3400

---

## Contents

<b>Safety Message to Installers and Service Personnel</b> .....	4
<b>Overview of the LED Beacon</b> .....	7
<b>Unpacking the Beacon</b> .....	7
<b>Permanently Mounting the Beacon</b> .....	8
<b>Wiring the LED Beacon</b> .....	10
<b>Pipe Mounting and Wiring the Beacon</b> .....	12
<b>Selecting a Flash Pattern</b> .....	13
<b>Selecting Sync or Alt</b> .....	14
<b>Selecting Single or Dual Color (if equipped)</b> .....	14
<b>Selecting the Color Order (Dual Color Models Only)</b> .....	15
<b>Re-setting the Beacon to the Default Settings</b> .....	15
<b>Maintaining the Beacon</b> .....	17
<b>Ordering Replacement Parts</b> .....	18
<b>Getting Technical Support and Service</b> .....	18
<b>Returning Product to Federal Signal</b> .....	18

## Figures

<b>Figure 1</b> Permanent-mount beacon (exploded view).....	9
<b>Figure 2</b> Pipe-mount beacon .....	12

## Tables

<b>Table 1</b> Product specifications.....	7
<b>Table 2</b> Mounting kit hardware .....	8
<b>Table 3</b> Wire Connections.....	10
<b>Table 4</b> Flash Patterns .....	16
<b>Table 5</b> Replacement Parts.....	17

## **Safety Message to Installers and Service Personnel**

### **▲ WARNING**

People's lives depend on your proper installation and servicing of Federal Signal products. It is important to read and follow all instructions shipped with this product. In addition, listed below are some other important safety instructions and precautions you should follow:

- To properly install or service this equipment, you must have a good understanding of automotive mechanical and electrical procedures and systems, along with proficiency in the installation and service of safety warning equipment. Always refer to the vehicle's service manuals when performing equipment installations on a vehicle.
- To be an effective warning device, this product produces bright light that can be hazardous to your eyesight when viewed at a close range. Do not stare directly into this lighting product at a close range or permanent damage to your eyesight may occur.
- Do not install the light system in an area that would block, impair or blind the driver's vision. Ensure that the light system is mounted in a position that is outside of the driver's field of vision, so the driver can safely operate the vehicle.
- A light system is a high current system. For the system to function properly, a separate negative (–) connection and positive (+) connection must be made. All negative connections should be connected to the negative battery terminal and a suitable fuse should be installed on the positive battery terminal connection as close to the battery as possible. Ensure that all wires and fuses are rated correctly to handle the device and system amperage requirements.
- Never attempt to install aftermarket equipment that connects to the vehicle wiring without reviewing a vehicle wiring

## ***Installation and Maintenance Instructions***

---

diagram available from the vehicle manufacturer. Ensure that your installation will not affect vehicle operation or mandated safety functions or circuits. Always check the vehicle for proper operation after installation.

- The lighting system components, especially the outer housing, get hot during operation. Be sure to disconnect power to the system and allow the system to cool down before handling any components of the system.
- Do not mount a radio antenna within 18 inches (45.7 cm) of the lighting system. Placing the antenna too close to the lighting system could cause the lighting system to malfunction or be damaged by strong radio fields. Mounting the antenna too close to the lighting system may also cause the radio noise emitted from the lighting system to interfere with the reception of the radio transmitter and reduce radio reception.
- Do not attempt to wash any unsealed electrical device while it is connected to its power source.
- DO NOT connect this system to the vehicle battery until ALL other electrical connections are made, mounting of all components is complete, and you have verified that no shorts exist. If the wiring is shorted to the vehicle body or frame, high current conductors can cause hazardous sparks resulting in electrical fires or flying molten metal.
- DO NOT install equipment or route wiring (or the plug-in cord) in the deployment path of an airbag.
- Before drilling into a vehicle structure, be sure that both sides of the surface are clear of anything that could be damaged. Remove all burrs from drilled holes. To prevent electrical shorts, grommet all drilled holes through which wiring passes. Also, ensure that the mounting screws do not cause electrical or mechanical damage to the vehicle.

## ***Installation and Maintenance Instructions***

---

- Because vehicle roof construction and driving conditions vary, do not drive a vehicle with a magnetically mounted warning light installed. The light could fly off the vehicle causing injury or damage. Repair of damage incurred because of ignoring this warning shall be the sole responsibility of the user.
- Locate the light system controls so the VEHICLE and CONTROLS can be operated safely under all driving conditions.
- After installation, test the light system to ensure that it is operating properly.
- Test all vehicle functions, including horn operation, vehicle safety functions and vehicle light systems, to ensure proper operation. Ensure that the installation has not affected the vehicle operation or changed any vehicle safety function or circuit.
- Scratched or dull reflectors or lenses will reduce the effectiveness of the lighting system. Avoid heavy pressure and use of caustic or petroleum based products when cleaning the lighting system.
- Replace any optical components that may have been scratched or crazed during system installation.
- Do not attempt to activate or de-activate the light system controls while driving in a hazardous situation.
- You should frequently inspect the light system to ensure that it is operating properly and that it is securely attached to the vehicle.
- After installation and testing are complete, provide a copy of these instructions to instructional staff and all operating personnel.

**Installation and Maintenance Instructions**

---

- File these instructions in a safe place and refer to them when maintaining and/or re-installing the product. Failure to follow all safety precautions and instructions may result in property damage, serious injury, or death.

**Overview of the LED Beacon**

The beacon uses an LED light source to provide a reliable signal with 25 selectable flash patterns. The beacon may be flush mounted, pipe mounted, or attached to brackets. The light can operate on a nominal 12 or 24 Vdc power source. Up to four beacons can be synchronized with each other by connecting their sync wires together after individual setup. Models are available with an automatic low power mode for night time operation. An optional branch guard is also available.

**Table 1** Product specifications

Input Voltage:	11 Vdc to 28 Vdc 12.8 Vdc or 25.6 Vdc (nominal)
Input Current:	3.75 A at 22.8 Vdc pulsed 1.88 A at 25.6 Vdc pulsed
Flash Rate:	See Table 4 on page 16 for a description of the patterns.
Dimensions:	Height: 5.25 in (13.3 cm) Diameter: 7.25 in (18.4 cm)
Weight:	(Tall): 2.8 lb (1.3 kg) (Short): 2.3 lb (1.0 kg)
Approvals:	SAE J845 Class 1 and CAC Title 13

**Unpacking the Beacon**

After unpacking the beacon, inspect it for damage that may have occurred in transit. If it has been damaged, file a claim immediately with the carrier, stating the extent of damage. Carefully check all envelopes, shipping labels, and tags before removing or destroying them. Ensure that the parts listed in Table 2 on page 8 are included in the package.

**Table 2** Mounting kit hardware

Qty.	Description
3	Screw, Pan-Head, Phillips, S.S
3	Nuts, Stainless Steel
1	Gasket

**Permanently Mounting the Beacon**

The installation requires installer-supplied minimum 18 AWG (1 mm<sup>2</sup>) red and black wire for lengths up to fifteen ft (5 m) or minimum 16 AWG (1.5 mm<sup>2</sup>) wire for lengths greater than 15 ft (5 m). A runner wire of minimum 18 AWG (8 ft max) should be used if you are synchronizing the flash pattern. Also required are two to five installer-supplied insulated butt connectors for the pipe mounting option and a switch with a current capacity of at least 5 A. An installer-supplied bushing for the wiring is optional. Selecting a flash pattern is optional and should be completed during the installation. For more information, see “Selecting a Flash Pattern” on page 13.

**NOTE:** Route the wires though a hole drilled into the metal of the mounting location.

To mount the beacon:

1. Scribe the locations of the three mounting holes in the base. (They are evenly spaced 120° apart on a 6.75 in diameter.)
2. Scribe a hole for the wires and an installer-supplied bushing.

**NOTICE**

***DRILLING PRECAUTIONS: Before drilling holes, check the area into which you plan to drill to ensure you do not damage vehicle components while drilling. All drilled holes should be deburred and all sharp edges should be smoothed. All wires going through drilled holes should be protected by a grommet or convolute/split-loom tubing.***



**Installation and Maintenance Instructions**

---

- 3. Drill a suitably sized hole at the scribed position for the bushing and wire routing hole. Seal the hole with the bushing or RTV. Otherwise, the wires may be routed through the drain notch in the base of the beacon if the cable is trimmed and terminated to two conductors, one for power and the other for ground. Open space must be left for water to drain.

**Figure 1** Permanent-mount beacon (exploded view)

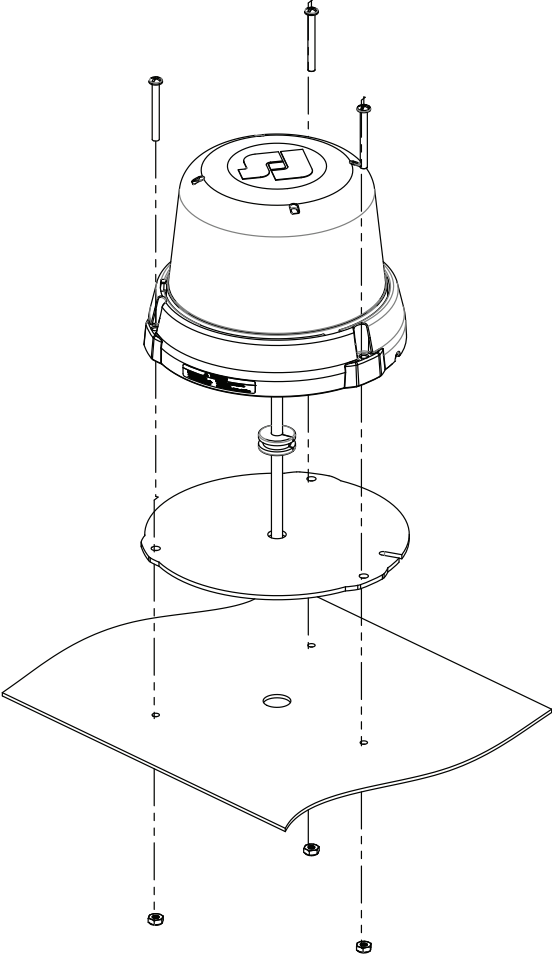

## Installation and Maintenance Instructions

---

4. Align the gasket over the drilled holes. Route the wires through the gasket and wire routing hole or through the notch in the base.
5. Secure the base to the mounting surface with the #10 pan-head screws and nuts.

### Wiring the LED Beacon

<b>NOTICE</b>
---------------

**REVERSE POLARITY/MISWIRING:** To avoid damage to the light, ensure that the input voltage is the same as the voltage rating of the light. Ensure that correct polarity is observed. Also ensure that unit is properly fused.

**Table 3** Wire Connections

Color	Description	Connection Point
Black	Ground	Battery Negative
Red	Mode 1	Switched Positive 12-24 Vdc
White	Mode 2	Switched Positive 12-24 Vdc
Brown	Low Power	Switched Positive 12-24 Vdc
Green	Sync/Program	Another Green Wire/ Positive 12 Vdc

To wire the beacon:

1. Determine the required functions and the length of wires needed to access them. A five-conductor cable can be selected for a full-featured installation. For lengths up to 15 ft (5 m), use minimum 18 AWG (1 mm<sup>2</sup>) wire. For lengths over 15 ft, use minimum 16 AWG (1.5 mm<sup>2</sup>) wire.
2. Strip 1/4 inch (5 mm) of insulation from the ends of the installer-supplied wires.

## ***Installation and Maintenance Instructions***

---

3. Use insulated butt connectors to connect the wires to the power cable of the beacon. Ensure that the connectors are securely crimped and properly insulated.
4. Connect the end of the fuse holder to the positive (+) terminal of the voltage source.
5. Connect the black (-) wire from the beacon to a known good vehicle ground as close to the beacon as practical.
6. Before wiring the beacon, refer to Table 3 on page 10 for the function of each wire.
7. The black wire is ground and is to be connected to a suitable chassis ground if it cannot be taken directly to the negative terminal of the battery.
8. The green wire has a dual function: It is the runner wire that synchronizes multiple beacons or other compatible products, and it also serves as the function/pattern programming wire.
9. The red wire powers the beacon in Mode 1 when connected to a fused, positive voltage.
10. The white wire powers the beacon in Mode 2 when connected to a fused, positive voltage.

**NOTE:** Mode 2 overrides Mode 1 if Mode 1 is active when Mode 2 is powered up.

11. The brown wire places the beacon (without automatic low power) into low-power mode when the wire is connected to a fused, positive voltage and either mode is activated.

For a beacon equipped with the automatic low-power feature, the brown wire prevents the beacon from entering low power when the beacon is connected to positive voltage.

## **Pipe Mounting and Wiring the Beacon**

The base was designed for the optional installation onto the end of a threaded 1 inch NPT pipe.

**Figure 2** Pipe-mount beacon

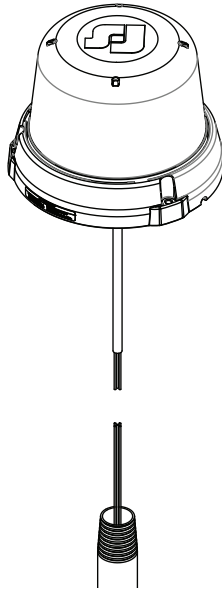

1. Determine the required functions and the length of wires needed to access them. A five conductor cable may be selected for a full installation. For lengths up to 15 ft (5 m), use min. 18 AWG (1 mm<sup>2</sup>) wire. For lengths over 15 ft, use min. 16 AWG (1.5 mm<sup>2</sup>) wire.
2. Strip 1/4 inch (5 mm) of insulation from the ends of the installer-supplied wires.
3. Use insulated butt connectors to connect the wires to the power cable of the beacon. Ensure that the connectors are securely crimped and properly insulated.
4. Connect the end of the fuse holder to the positive (+) terminal of the voltage source.

## ***Installation and Maintenance Instructions***

---

5. Route the wires (or five-conductor cable) through the pipe to the location of the installer-supplied switch with a current capacity of at least 5 A).
6. Screw the beacon onto the pipe. Ensure that the wires are not pinched inside the pipe or twisted severely.
7. Connect one terminal of the installer-supplied switch to each required function wire of the beacon.
8. Use minimum 18 AWG (1 mm<sup>2</sup>) wire to connect the remaining switch terminal to one end of the supplied fuse holder and 5 A fuse at 12 Vdc, 3 A fuse at 24 Vdc
9. Connect the other end of the fuse holder to the positive (+) terminal of the voltage source.
10. Connect the black (-) wire from the beacon to a known good vehicle ground as close to the beacon as practical.

### **Configuring the Beacon**

If the beacon's operating function are to changed from default, perform the following steps while the green wire is disconnected from the system.

### **Selecting a Flash Pattern**

#### **⚠ WARNING**

***LIGHT HAZARD: This product contains a high intensity LED device. To prevent permanent eye damage, DO NOT stare into the light beam at close range.***

Selecting a flash pattern from the beacon's internal library of flash patterns is optional. It should be done during installation. For the flash patterns, see Table 4 on page 16.

To select a flash pattern:

1. Select the Mode 1 (red wire) or Mode 2 (white wire)
2. Apply power (+12-24 Vdc) to that wire.

3. Select a flash pattern by tapping the green wire to + 12-24 Vdc until desired pattern is reached.

**NOTE:** When tapping the green wire to change patterns, do not hold power for longer than 1 second, or other features of the beacon will change.

### **Selecting Sync or Alt**

#### **⚠ WARNING**

***When setting up devices to be synchronized, they must never be operated without a good ground connection. If a poor ground connection exists, the unit will operate erratically, and will void the warranty. Routinely inspect all connections to ensure they are secure.***

The beacon can synchronize with other beacons. It will either flash with or alternate the timing of the flashes with other beacons. Select this feature separately for Mode 1 or Mode 2.

To synchronize your selected flash pattern:

1. Activate the mode (1 or 2) for which the synchronize feature is to be set.
2. Connect and hold the green wire to the positive voltage source until the beacon pulses twice, then release it. The beacon switches from its initial setting to its opposite. Flash with becomes Alternate, or Alternate becomes Flash with.
3. To synchronize, after set-up, connect the green wires together.

For this feature to operate, all green wires should be permanently connected together after all of the beacons in the system are configured.

### **Selecting Single or Dual Color (if equipped)**

The beacon can be made to either flash a single color or two colors. This is done separately for Mode 1 or 2.

To select single or dual color:

1. Activate the mode for which this color feature is to be set.
2. Connect and hold the green wire to power until the beacon pulses 3 times, then release it.
3. The beacon switches from its initial setting to its opposite. Single Color becomes Dual Color or Dual Color becomes Single Color.

### **Selecting the Color Order**

You can set the order in which a beacon flashes. The order is selected separately for Mode 1 or Mode 2.

To select the color order:

1. Activate the mode for which this color feature is to be set.
2. Hold the green wire to the positive voltage source until the beacon pulses four times, then release the wire. The beacon switches color from the initial setting to its opposite. For example: A dual color, amber-red beacon set to flash amber then red, will change to flashing red then amber. A dual color, amber-red beacon set to the single color red, will become amber.

### **Re-setting the Beacon to the Default Settings**

To reset the beacon mode to the default settings. Apply power to the green wire while either Mode 1 or Mode 2 are powered. Hold the wire to the power source until the beacon pulses six times and then remove power. Repeat for each Mode you want to reset.

**NOTE:** No change occurs, if you remove power from the green wire after five pulses and before the pulse sixth pulse finishes.

**Table 4** Flash Patterns

<b>Pattern No.</b>	<b>Description</b>	<b>Flash Rate (FPM)</b>
1 *	Double Quad	60
2	Chopped Double	60
3	Double Pulse	80
4	Pulsing Quad	60
5	Triple FedPulse	60
6	SCDOT	81
7	Breathing	60
8	Random Full, All Patterns	Various
9	Random, Select Patterns #11-25	Various
10**	Steady for 3	N/A
11	Single Flash, Slow	75
12	Single Flash	120
13	Double Flash	80
14	Double Flash Fast	120
15	Triple Flash	80
16	Triple Flash Fast	120
17	Quad Flash Slow	60
18	Quad Flash	75
19	Quad Flash Fast	95
20	Quad FedPulse	75
21	5x Flash	75
22	7x Flash	80
23	Single Flash 120 FPM/Quad 60 FPM	120/60
24	Decelerating	60
25	Accelerating	60

\*Pattern 1 is the default for Mode 1

\*\*Pattern 10 is the default for Mode 2



## **Maintaining the Beacon**

Frequently inspect the beacon to ensure that it is securely attached to the vehicle and operates properly. Clean the beacon with a mild soap and a soft rag.

**Table 5** Replacement Parts

<b>Description</b>	<b>Part No.</b>
Dome, Tall, Amber	862702014-02
Dome, Short, Amber	862702014-02-S
Dome, Tall, Blue	862702014-03
Dome, Short, Blue	862702014-03-S
Dome, Tall, Red	862702014-04
Dome, Short, Red	862702014-04-S
Dome, Tall, Clear	862702014-05
Dome, Short, Clear	862702014-05-S
Dome, Tall, Green	862702014-06
Dome, Short, Green	862702014-06-S
O-Ring, Lens	862702247
Pad, Mounting	862702265

## **Ordering Replacement Parts or Technical Support Service**

Federal Signal Service Department

1-800-433-9132 / 1-708-534-3400

Monday-Friday, 7 a.m. to 5 p.m. (CST)

[fstechsupport@fedsig.com](mailto:fstechsupport@fedsig.com)

[www.fedsig.com](http://www.fedsig.com)

## **Returning a Product to Federal Signal**

All products returned must be accompanied with a Returned Merchandise Authorization (RMA) number. To obtain an RMA number, call 1-800-433-9132.