

25500121 Rev. A0 0414

Safety Message to Installers of Warning Light Equipment

⚠ WARNING

People's lives depend on your proper installation and servicing of Federal Signal products. It is important to read and follow all instructions shipped with this product and the original product. Listed below are some other important safety instructions and precautions you should follow:

- To properly install a light assembly, you must have a good understanding of automotive electrical procedures and systems, along with proficiency in the installation and use of safety warning equipment.
- Do not install equipment or route wiring in the deployment path of an airbag.
- If a vehicle seat is temporarily removed, verify with the vehicle manufacturer if the seat needs to be recalibrated for proper airbag deployment.
- When drilling into a vehicle structure, be sure that both sides of the surface are clear of anything that could be damaged.
- To be an effective warning device, this product produces bright light that can be hazardous to your eyesight when viewed at close range. Do not stare directly into this lighting product at close range or permanent damage to your eyesight may occur.
- You should frequently inspect the light system to ensure that it is operating properly and that it is securely attached to the vehicle.
- Refer to the instruction sheets included with related products for additional precautions and information.
- File these instructions in a safe place and refer to them when maintaining or reinstalling the product.

Failure to follow all safety precautions and instructions may result in property damage, serious injury, or death.

Overview

This publication has instructions for using the IPX-GRL7 Grille Mounting Kit to mount the Impaxx 300 and 600, Viper EXT, Micropulse 300 and 600 lightheads between the top of the grille and the radiator core support of the Chevy Tahoe.

NOTE: For electrical installation instructions, refer to the Installation and Maintenance Instructions packed with the lighthead.

Unpacking the Kit

After unpacking the kit, inspect it for damage that may have occurred in transit. If it has been damaged, do not attempt to install or operate it. File a claim immediately with the carrier, stating the extent of damage. Carefully check all envelopes, shipping labels, and tags before removing or destroying them. Ensure that the parts listed in Table 1 on page 2 are included in the package. If you are missing any parts, contact Customer Support at 1-800-264-3578, 7 a.m. to 5 p.m., Monday through Friday (CT). Disposal of all shipping materials must be carried out in accordance with national and local codes and standards.

Table 1 Kit contents

Qty.	Description	Part Number
1	Bracket, DS Grille Mount, Tahoe	861300712-DS
1	Bracket, PS Grille Mount, Tahoe	861300712-PS

Installing the Lights

IMPORTANT: Plan all cable routing before installation.

⚠ WARNING

AIRBAG DEPLOYMENT — *Do not install equipment or route wiring in the deployment path of an airbag. Failure to observe this warning will reduce the effectiveness of the airbag or potentially dislodge the equipment, causing serious injury or death.*

NOTICE

DRILLING PRECAUTIONS — *Before drilling holes, check the area into which you plan to drill to ensure you do not damage vehicle components. All drilled holes should be deburred and all sharp edges should be smoothed. All wires going through drilled holes should be protected by a grommet or convolute/split-loom tubing.*

To install the lighthoods:

1. Attach the lighthoods to the brackets using the hardware supplied with the lighthood as shown in Figures 1 through 3 on page 3.
2. To access the mounting area, disassemble the vehicle per the manufacturer’s service manual.
3. Connect the lights as described in the instructions provided with the lights.
4. In the areas shown in Figure 4 on page 4, remove the bolts on the top of the grille that secure it to the radiator core support.
5. Slip the brackets between the top of the grille and the radiator core support, and center the holes as shown in Figure 4.
6. Attach the brackets through the grille into the radiator core support using the bolts removed in step 4.
7. Connect the lights as described in the instructions provided with the lights.

⚠ WARNING

LIGHT HAZARD — *To be an effective warning device, an emergency warning system produces bright light that can be hazardous to your eyesight when viewed at close range. Do not stare directly into the lights at close range or permanent damage to your eyesight may occur.*

8. Test the lights for proper operation.
9. Reassemble the vehicle per the manufacturer’s service manual.

Figure 1 Impaxx attached to bracket (driver side)

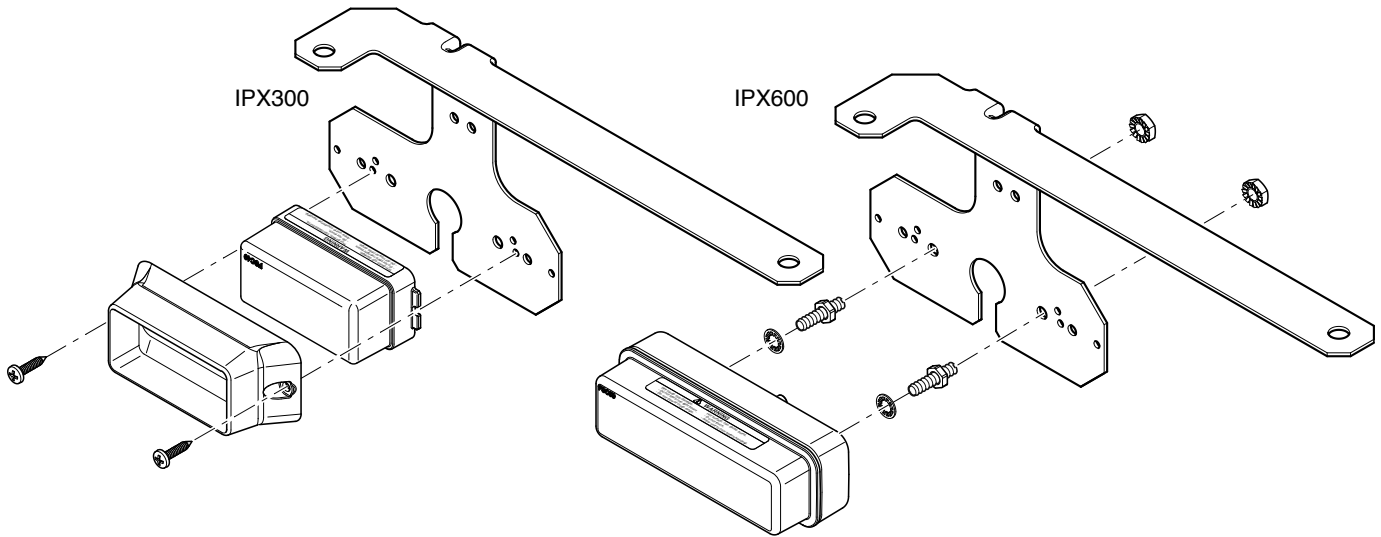

Figure 2 MicroPulse attached to bracket (driver side)

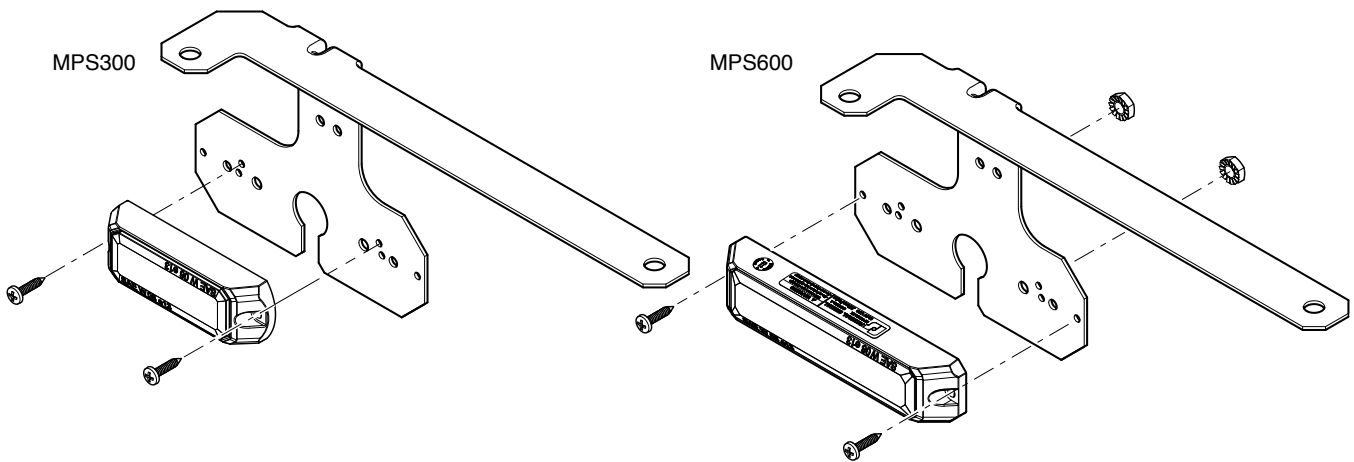

Figure 3 Viper EXT attached to bracket (driver side)

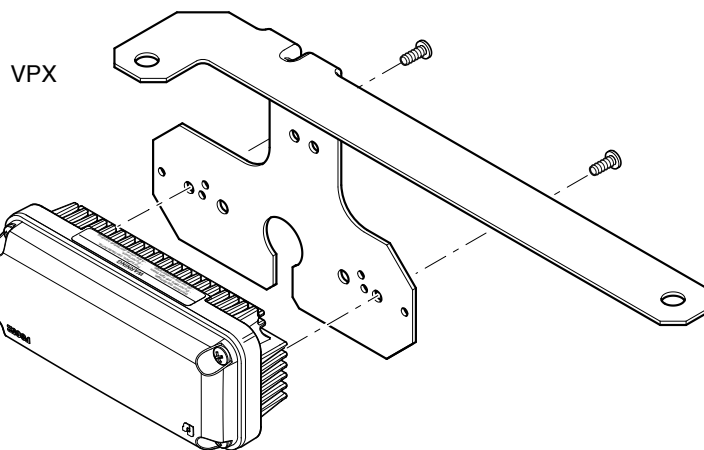
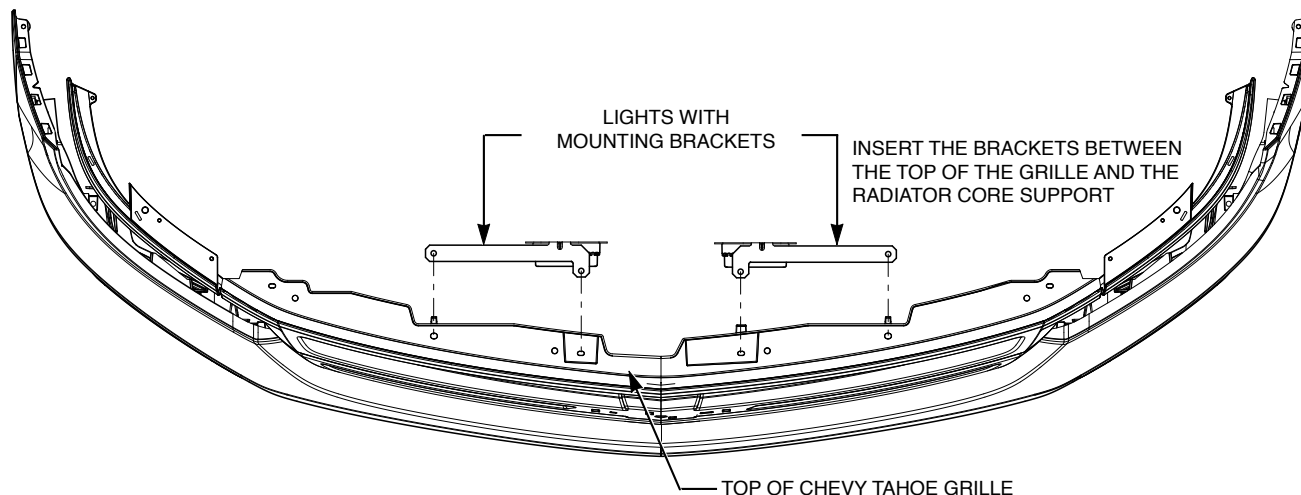

Figure 4 Mounting locations of bracket/light assemblies



Getting Technical Support and Service

For technical support and service, please contact:

Federal Signal Corporation
Service Department
Public Safety Systems
Phone: 1-800-433-9132
Fax: 1-800-343-9706
Email: empserviceinfo@fedsig.com
www.fedsig.com

Ordering Replacement Parts

To order replacement parts, please contact your local dealer/distributor or:

Customer Support
Federal Signal Corporation
Phone: 1-800-264-3578
www.fedsig.com