



► Model COMFL1-B-IS

Blue Forklift LED Safety Light

Model COMFL1-B-IS is a Blue Forklift LED light designed to improve work area safety. This safety light alerts pedestrians and other vehicles with a steady blue signal warning that a forklift is approaching. COMFL1-B-IS contains (2) 5W Blue LEDs that projects an intense, steady beam onto the floor surface.

This safety light has a compact design that is approximately 3" deep and 3.8" wide. It also includes a U-bracket to accommodate front, back, or side mounting on a forklift. COMFL1-B-IS features a die-cast aluminum housing with polycarbonate lens and is available as a 10-80 VDC model.

F E A T U R E S

- Ideal for alerting pedestrians and other vehicles that a forklift is approaching
- Die-cast aluminum housing with polycarbonate lens
- Two 5W Blue LEDs
- 10-80 VDC
- Projects an intense, steady blue beam onto floor surface
- Compact design—approximately 3" deep and 3.8" wide
- Comes with a U-bracket—can be mounted to a forklift or other moving vehicle
- Multiple lights can be mounted to the forklift or vehicle to alert to the front, back and/or sides
- IP67 enclosure

MODEL	OPERATING VOLTAGE	OPERATING CURRENT
COMFL1-B-IS	10-80VDC	0.5A @ 12.8VDC

Blue Forklift LED Safety Light (COMFL1-B-IS)

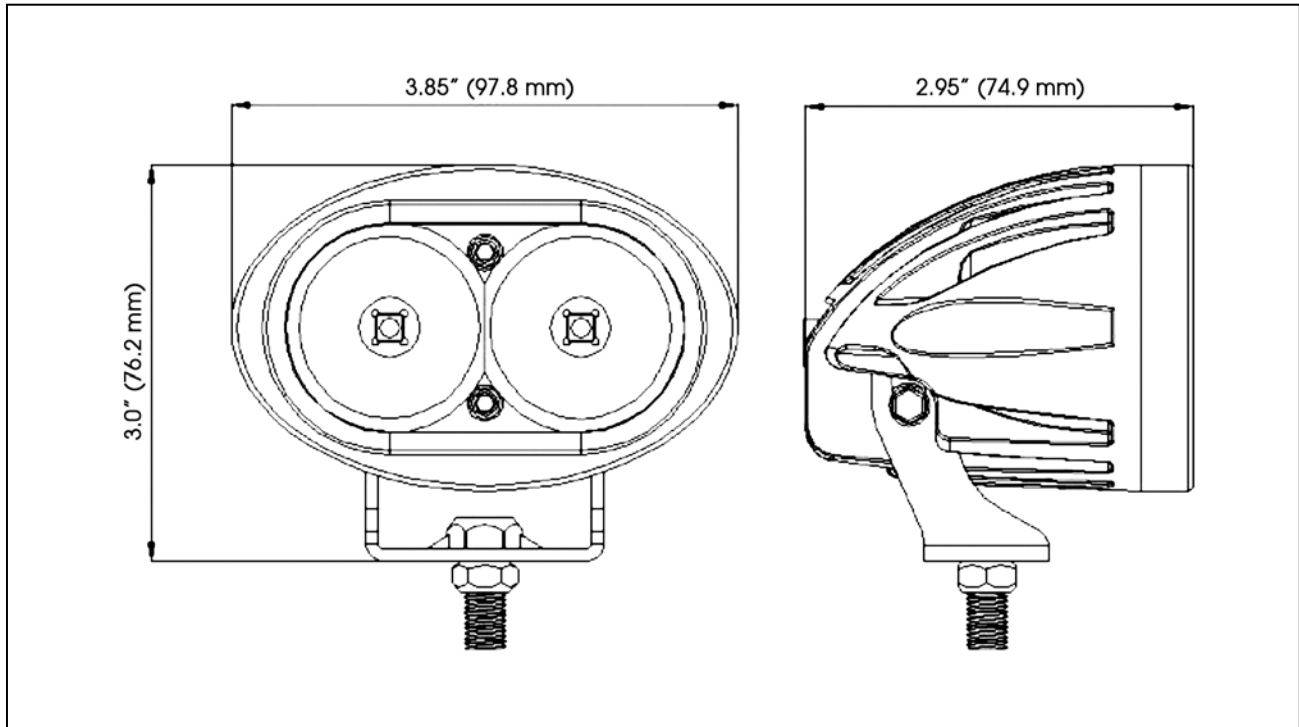

SPECIFICATIONS

Voltage:	10-80 VDC	
Current Draw:	0.5 A @ 12.8 VDC	
Operating Temperature:	-22°F to 176°F	-30° to 80°C
Net Weight	0.69 lbs	0.31 kg
Shipping Weight	1.0 lbs	0.45 kg
Height:	3.0"	76.2 mm
Width:	3.85"	97.8 mm
Depth:	2.95"	74.9 mm

HOW TO ORDER

Specify Model:
COMFL1-B-IS – Blue Forklift LED Safety Light