

Safety Message to Installers of Federal Signal Siren Speakers

⚠ WARNING

People's lives depend on your proper installation and servicing of Federal Signal products. It is important to read and follow all instructions shipped with this product and the original product. In addition, listed below are some other important safety precautions you should follow:

Qualifications

- To properly install an electronic siren: you must have a good understanding of automotive electrical procedures and systems, along with proficiency in the installation and service of safety warning equipment. Always refer to the vehicle's service manuals when performing equipment installations on a vehicle.

Sound Hazards

- Your hearing and the hearing of others, in or close to your emergency vehicle, could be damaged by loud sounds. This can occur from short exposures to very loud sounds, or from longer exposures to moderately loud sounds. For hearing conservation guidance, refer to federal, state, or local recommendations. OSHA Standard 1910.95 offers guidance on "Permissible Noise Exposure."
- All effective sirens and horns produce loud sounds (120 dB) that may cause permanent hearing loss. Always minimize your exposure to siren sound and wear hearing protection. Do not sound the siren indoors or in enclosed areas where you and others will be exposed to the sound.
- Federal Signal siren amplifiers and speakers are designed to work together as a system. Combining a siren and speaker from different manufacturers may reduce the warning effectiveness of the siren system and may damage the components. You should verify or test your combination to make sure the system works together properly and meets federal, state and local standards or guidelines.

During Installation

- DO NOT get metal shavings inside the product. Metal shavings in the product can cause the system to fail. If drilling must be done near the unit, place an ESD approved cover over the unit to prevent metal shavings from entering the unit. Inspect the unit after mounting to be sure there are no shavings present in or near the unit.
- DO NOT connect this system to the vehicle battery until ALL other electrical connections are made, mounting of all components is complete, and you have verified that no shorts exist. If wiring is shorted to vehicle frame, high current conductors can cause hazardous sparks resulting in electrical fires or flying molten metal.
- Be sure the siren amplifier and speaker(s) in your installation have compatible wattage ratings.
- In order for the electronic siren to function properly, the ground connection must be made to the NEGATIVE battery terminal.
- Sound output will be severely reduced if any objects are in front of the speaker. If maximum sound output is required for your application, you should ensure that the front of the speaker is clear of any obstructions.

Installation and Operating Instructions

- Install the speaker(s) as far forward on the vehicle as possible, in a location that provides maximum signaling effectiveness and minimizes the sound reaching the vehicle's occupants. Refer to the National Institute of Justice guide 500-00 for further information.
- Mounting the speakers behind the grille will reduce the sound output and warning effectiveness of the siren system. Before mounting speakers behind the grille, make sure the vehicle operators are trained and understand that this type of installation is less effective for warning others.
- Sound propagation and warning effectiveness will be severely reduced if the speaker is not facing forward. Carefully follow the installation instructions and always install the speaker with the projector facing forward.
- DO NOT install the speaker(s) or route the speaker wires where they may interfere with the operation of air bag sensors.
- Installation of two speakers requires wiring speakers in phase.
- Never attempt to install aftermarket equipment, which connects to the vehicle wiring, without reviewing a vehicle wiring diagram available from the vehicle manufacturer. Insure that your installation will not affect vehicle operation and safety functions or circuits. Always check the vehicle for proper operation after installation.
- DO NOT install equipment or route wiring or cord in the deployment path of an air bag.
- Locate the control head so that the vehicle, controls, and microphone can be operated safely.
- When drilling into a vehicle structure, be sure that both sides of the surface are clear of anything that could be damaged.

After Installation

- After installation, test the siren system and light system to ensure that it is operating properly.
- Test all vehicle functions, including horn operation, vehicle safety functions and vehicle light systems, to ensure proper operation. Ensure that installation has not affected vehicle operation or changed any vehicle safety function or circuit.
- After testing is complete, provide a copy of these instructions to the instructional staff and all operating personnel.
- File these instructions in a safe place and refer to them when maintaining and/or reinstalling the product.

Failure to follow all safety precautions and instructions may result in property damage, serious injury, or death to you or others.

Introduction

The Model BP200-LL is a compact speaker designed to be flush-mounted on a vehicle panel or bumper.

Unpacking the Kit

After unpacking the kit, inspect it for damage that may have occurred in transit. If it has been damaged, file a claim immediately with the carrier, stating the extent of damage. Carefully check all envelopes, shipping labels, and tags before removing or destroying them. Ensure that the parts shown in Table 1 on page 2 are contained in the packing carton. If you are missing any parts, contact Customer Support at 1-800-264-3578, 7 a.m. to 5 p.m., Monday through Friday (CT).

Table 1 Kit contents

| Qty. | Description | Item No. |
|------|------------------------------|-----------|
| 1 | ES100-ESFMT-LL | 856702438 |
| 1 | Speaker Assembly | 7059125 |
| 4 | Screw, Button Head SS | 7065078 |
| 1 | Speaker Wire Assembly, 20 ft | 7072A031 |

Installing the Service Kit Mounting Feet

⚠ CAUTION

HEAVY OBJECT—Use lifting aids and proper lifting techniques when removing or replacing the lightbar. Failure to follow this warning may cause personal injury.

1. Select an appropriate mounting location that provides both adequate support and sufficient clearance for the speaker assembly. In addition, the mounting location should provide maximum signalling effectiveness while minimizing the sound reaching the vehicle’s occupants.

NOTICE

DRILLING PRECAUTIONS — When drilling holes, check the area into which you are drilling to be sure you do not damage components while drilling. All drilled holes should be deburred and all sharp edges should be smoothed. All wire routings going through drilled holes should be protected by a grommet or convolute/split loom tubing.

IMPORTANT: Plan all cable routing before completing the installation. Plan the location of the wire-

2. Use Figure 1 on page 4 as a guide to cut the pattern in the bumper.

⚠ WARNING

To avoid reduction of sound output and damage to speaker, ensure that speaker is mounted with wires protruding from bottom of unit.

3. See Figure 2 on page 4. Place the speaker in position on the rear side of the mounting surface.
4. Place the grille in position and secure the assembly in position using the supplied four 1/4-20 x 1 in button-head screws.
5. See Figure 3 on page 5. Connect the cable from the amplifier to the matching connector on the speaker.

Figure 1 Dimensions of mounting surface

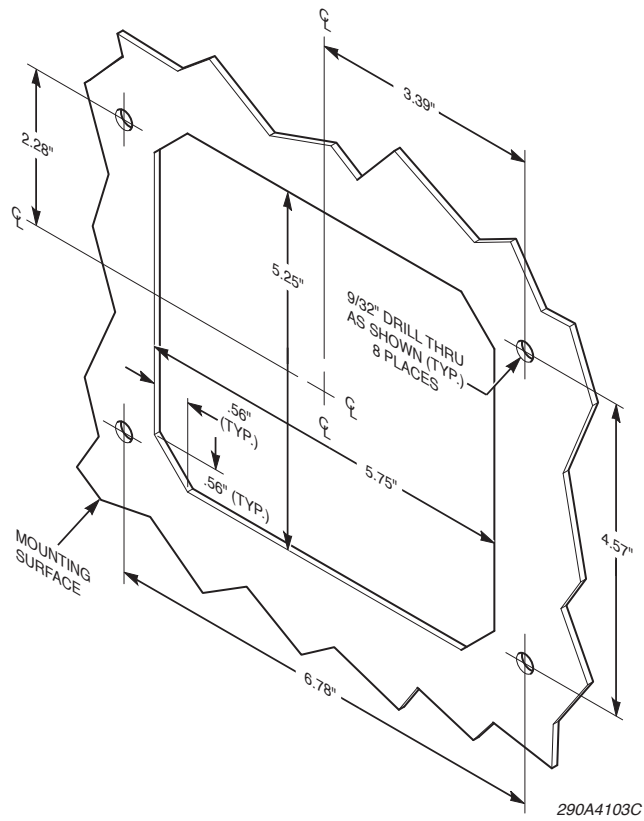

Figure 2 Exploded view of mounted speaker

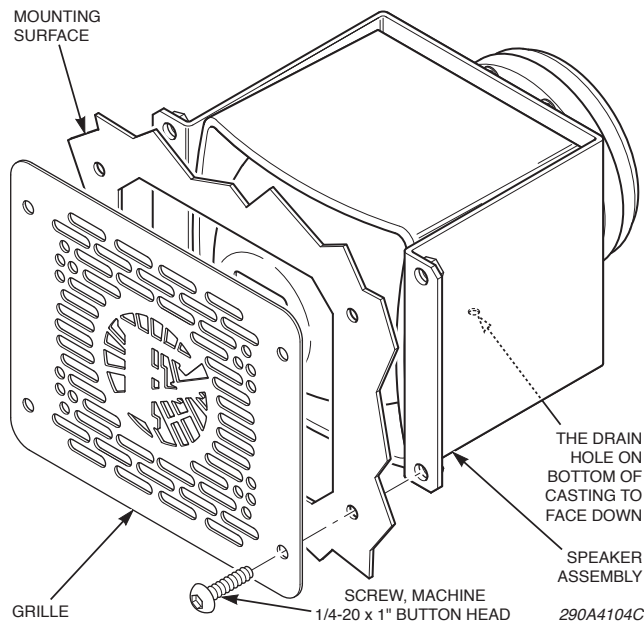

Figure 3 Speaker cable and connector

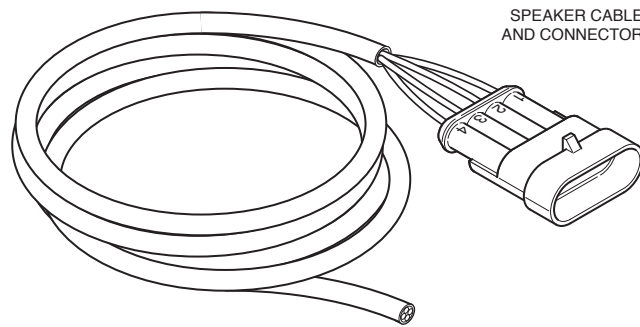

Table 1 Kit contents

| Connector Position No. | Wire Color | Speaker Connection |
|------------------------|------------|-----------------------|
| 1 | Black | Front Driver Neg. (-) |
| 2 | White | Front Driver Pos. (+) |
| 3 | Green | Rear Driver Neg. (-) |
| 4 | Red | Rear Driver Pos. (+) |

Safety Message to Installers of Federal Signal Siren Speakers

⚠ WARNING

The lives of people depend on your safe operation of Federal products. It is important to read and follow all instructions shipped with the products. In addition, listed below are some other important safety instructions and precautions you should follow:

Qualifications

- To properly use an electronic siren and speaker(s): you must have a good understanding of general vehicle operation, a high proficiency in the use of safety warning equipment, and thorough knowledge of state and federal UNIFORM TRAFFIC CODES.

Sound Hazards

- Your hearing and the hearing of others, in or close to your emergency vehicle, could be damaged by loud sounds. This can occur from short exposures to very loud sounds, or from longer exposures to moderately loud sounds. For hearing conservation guidance, refer to federal, state, or local recommendations. OSHA Standard 1910.95 offers guidance on “Permissible Noise Exposure.”
- All effective sirens and horns produce loud sounds (120 dB) that may cause permanent hearing loss. Always minimize your exposure to siren sound, roll up your windows and wear hearing protection. Do not sound the siren indoors or in enclosed areas where you and others will be exposed to the sound. Only use the siren for emergency response situations.

Sound Limitations

- Before using the vehicle, check to see if the siren speakers are concealed from view. If the siren speaker is not in clear view on the front of the vehicle, use extra caution when operating the vehicle. A concealed siren speaker installation is less effective at warning others.
- Maximum sound output will be severely reduced if any objects are in front of the speaker. If your installation has obstructions in front of the speaker, drive even more cautiously.
- Frequently inspect the speaker to ensure that it is clear of any obstruction, such as mud or snow, which will reduce maximum sound output.

Signaling Limitations

- Be aware that the use of your visual and audible signaling devices does not give you the right to force your way through traffic. Your emergency lights, siren, and actions are REQUESTING the right-of-way.
- Although your warning system is operating properly, it may not alert everyone. People may not hear, see, or heed your warning signal. You must recognize this fact and continue driving cautiously.
- Situations may occur which obstruct your warning signal when natural or man-made objects are between your vehicle and others. This can also occur when you raise your hood or trunk lid. If these situations occur, be especially careful.

Driving Limitations

- At the start of your shift, you should ensure that the light/sound system is securely attached to the vehicle and operating properly.
- If the unique combination of emergency vehicle equipment installed in your vehicle has resulted in the siren controls being installed in a position that does not allow you to operate them by touch only, OPERATE CONTROLS ONLY WHILE YOUR VEHICLE IS STOPPED.
- If driving conditions require your full attention, you should avoid operating the siren controls while the vehicle is in motion.

Continuing Education

- File these instructions in a safe place and refer to them periodically. Give a copy of these instructions to new recruits and trainees.

Failure to follow these safety precautions may result in property damage, serious injury, or death to you or others.

Operating the Siren

Refer to the instructions packed with the electronic siren for operation.

Safety Message to Operators of Federal Signal Siren Speakers

⚠ WARNING

The lives of people depend on your safe operation of Federal products. It is important to read and follow all instructions shipped with the products. In addition, listed below are some other important safety instructions and precautions you should follow:

Qualifications

To properly use an electronic siren and speaker(s), you must have a good understanding of general vehicle operation, a high proficiency in the use of safety warning equipment, and thorough knowledge of state and federal UNIFORM TRAFFIC CODES.

Sound Hazards

- Your hearing and the hearing of others, in or close to your emergency vehicle, could be damaged by loud sounds. This can occur from short exposures to very loud sounds, or from longer exposures to moderately loud sounds. For hearing conservation guidance, refer to federal, state, or local recommendations. OSHA Standard 1910.95 offers guidance on “Permissible Noise Exposure.”
- All effective sirens and horns produce loud sounds(120 dB) that may cause permanent hearing loss. Always minimize your exposure to siren sound, roll up your windows and wear hearing protection. Do not sound the siren indoors or in enclosed areas where you and others will be exposed to the sound. Only use the siren for emergency response situations.

Sound Limitations

- Before using the vehicle, check to see if the siren speakers are concealed from view. If the siren speaker is not in clear view on the front of the vehicle, use extra caution when operating the vehicle. A concealed siren speaker installation is less effective at warning others.
- Maximum sound output will be severely reduced if any objects are in front of the speaker. If your installation has obstructions in front of the speaker, drive even more cautiously.
- Frequently inspect the speaker to ensure that it is clear of any obstruction, such as mud or snow, which will reduce maximum sound output.

Signaling Limitations

- Be aware that the use of your visual and audible signaling devices does not give you the right to force your way through traffic. Your emergency lights, siren, and actions are REQUESTING the right-of-way.
- Although your warning system is operating properly, it may not alert everyone. People may not hear, see, or heed your warning signal. You must recognize this fact and continue driving cautiously.
- Situations may occur which obstruct your warning signal when natural or man-made objects are between your vehicle and others. This can also occur when you raise your hood or trunk lid. If these situations occur, be especially careful.

Driving Limitations

- At the start of your shift, you should ensure that the light/sound system is securely attached to the vehicle and operating properly.
- If the unique combination of emergency vehicle equipment installed in your vehicle has resulted in the siren controls being installed in a position that does not allow you to operate them by touch only OPERATE CONTROLS ONLY WHILE YOUR VEHICLE IS STOPPED.
- If driving conditions require your full attention, you should avoid operating the siren controls while the vehicle is in motion.

Continuing Education

- File these instructions in a safe place and refer to them periodically. Give a copy of these instructions to new recruits and trainees. Failure to follow these safety precautions may result in property damage, serious injury, or death to you, to passengers, or to others.

Safety Message to Operators of Federal Signal Siren Speakers

WARNING

The lives of people depend on your proper servicing of Federal products. It is important to read and follow all instructions shipped with the products. In addition, listed below are some other safety instructions and precautions you should follow:

- Read and understand all instructions in this manual before servicing the electronic siren or speaker.
- To properly service an electronic siren or speaker, you must have a good understanding of automotive electrical procedures and systems, along with proficiency in the installation and service of safety warning equipment. Always refer to the vehicle's service manuals when performing service on a vehicle.
- Electronic circuit and speaker repairs must be performed by a qualified and competent electronic technician.
- Your hearing and the hearing of others, in or close to your emergency vehicle, could be damaged by loud sounds. This can occur from short exposures to very loud sounds, or from longer exposures to moderately loud sounds. For hearing conservation guidance, refer to federal, state, or local recommendations. OSHA Standard 1910.95 offers guidance on "Permissible Noise Exposure."
- All effective sirens and horns produce loud sounds (120 db) that may cause permanent hearing loss. Always minimize your exposure to siren sound and wear hearing protection. Do not sound the siren indoors or in enclosed areas where you and others will be exposed to the sound.
- DO NOT connect this system to the positive terminal of the battery until servicing is complete, and you have verified that there are not short circuits to ground.
- In order for the electronic siren to function properly, the ground connection must be made to the NEGATIVE battery terminal.

- After repair, test the electronic siren and speaker system to ensure that it is operating properly.
- Federal Signal siren amplifiers and speakers are design to work together as a system. Combining a siren and speaker from different manufacturers may reduce the warning effectiveness of the siren system and may damage the components. You should verify or test your combination to make sure they system works together properly and meets both federal, state and local standards or guidelines.

Failure to follow all safety precautions and instructions may result in property damage, serious injury, or death to you or others.

Ordering Replacement Parts / Technical Support Service

Federal Signal Service Department

1-800-433-9132 / 1-708-534-3400

Monday-Friday, 7 a.m. to 5 p.m. (CST)

fstechsupport@fedsig.com

www.fedsig.com

Returning a Product to Federal Signal

All products returned must be accompanied with a Returned Merchandise Authorization (RMA) number. To obtain an RMA number, call 1-800-433-9132.

Limited Warranty

This product is subject to and covered by a limited warranty, a copy of which can be found at www.fedsig.com/SSG-Warranty. A copy of this limited warranty can also be obtained by written request to Federal Signal Corporation, 2645 Federal Signal Drive, University Park, IL 60484, email to info@fedsig.com or call +1 708-534-3400.

This limited warranty is in lieu of all other warranties, express or implied, contractual or statutory, including, but not limited to the warranty of merchantability, warranty of fitness for a particular purpose and any warranty against failure of its essential purpose.



2645 Federal Signal Drive
University Park, Illinois 60484

www.fedsig.com

Customer Support

Police/Fire-EMS: 800-264-3578 • +1 708 534-3400

Work Truck: 800-824-0254 • +1 708 534-3400

Technical Support 800-433-9132 • +1 708 534-3400