



**FEDERAL SIGNAL**  
Safety and Security Systems

# **Model XSMBKT03 Visor Mount Kit for the XStream™ Lights**

---

## ***Installation Instructions***

## Limited Warranty

This product is subject to and covered by a limited warranty, a copy of which can be found at [www.fedsig.com/SSG-Warranty](http://www.fedsig.com/SSG-Warranty). A copy of this limited warranty can also be obtained by written request to Federal Signal Corporation, 2645 Federal Signal Drive, University Park, IL 60484, email to [info@fedsig.com](mailto:info@fedsig.com) or call +1 708-534-3400.

This limited warranty is in lieu of all other warranties, express or implied, contractual or statutory, including, but not limited to the warranty of merchantability, warranty of fitness for a particular purpose and any warranty against failure of its essential purpose.



**FEDERAL SIGNAL**  
Safety and Security Systems

2645 Federal Signal Drive  
University Park, Illinois 60484-3167

[www.fedsig.com](http://www.fedsig.com)

Customer Support

Police/Fire-EMS: 800-264-3578 • +1 708 534-3400

Work Truck: 800-824-0254 • +1 708 534-3400

Technical Support 800-433-9132 • +1 708 534-3400

---

## Contents

<b>Safety Messages to Installers and Users of Warning Light Equipment.....</b>	<b>5</b>
<b>Introduction.....</b>	<b>5</b>
<b>Unpacking the Kit.....</b>	<b>6</b>
<b>Installing the Brackets.....</b>	<b>6</b>
<b>Getting Technical Support and Service.....</b>	<b>8</b>

### Table

<b>Table 1 Kit Contents.....</b>	<b>6</b>
----------------------------------	----------

### Figure

<b>Figure 1 Visor clip attached to light.....</b>	<b>7</b>
---	----------

Copyright 2017 Federal Signal Corp.

XStream is a trademark of Federal Signal Corporation.

TORX® is a registered trademark of Acument Intellectual Properties LLC  
PLASTITE is a registered trademark of Research Engineering & Manufacturing, Inc.

## **Safety Messages to Installers and Users of Warning Light Equipment**

### **⚠ WARNING**

People's lives depend on your safe installation of our products. It is important to read, understand and follow all instructions shipped with the products. In addition, listed below are some other important safety instructions and precautions you should follow:

- To properly install this light, you must have a good understanding of automotive electrical procedures and systems along with proficiency in the installation and use of safety warning equipment.
- DO NOT install equipment or route wiring in the deployment path of an airbag.
- If a vehicle seat is temporarily removed, verify with the vehicle manufacturer if the seat needs to be recalibrated for proper airbag deployment.
- You should frequently inspect the light to ensure that it is operating properly and that it is securely attached to the visor.
- Do not stare directly into the lights at a close range or permanent damage to your eyesight may occur.
- When drilling into a vehicle structure, be sure that both sides of the surface are clear of anything that could be damaged.
- Refer to the instructions packed with related products for additional precautions and information.
- File these instructions in a safe place and refer to them when maintaining and/or reinstalling the product.

Failure to follow all safety precautions and instructions may result in property damage, serious injury, or death.

### **Introduction**

This publication has instructions for using the XSMBKT03 Headliner Mount to mount single- and dual-head XStream<sup>™</sup> models.

**NOTE:** For electrical installation instructions, refer to the Installation and Maintenance Instructions packed with the lighthouse.

## Installation Instructions

---

### Unpacking the Kit

After unpacking the kit, inspect it for damage that may have occurred in transit. If it has been damaged, do not attempt to install or operate it. File a claim immediately with the carrier, stating the extent of damage. Carefully check all envelopes, shipping labels, and tags before removing or destroying them. Ensure that the parts in the Kit Contents list are included in the package. If you are missing any parts, contact Customer Support at 1-800-264-3578, 7 a.m. to 5 p.m., Monday through Friday (CT).

**Table 1** Kit Contents

Qty.	Description	Part Number
2	Screw, #8, 48-2 PLASTITE® Equivalent, No. 6 L	70000705-05
2	Screw, #10, Type B, Pan-Head, Torx®, Steel Zinc	7011246-08
1	Bracket, Headliner Mount	861301918

### Installing the Brackets

#### **WARNING**

**AIRBAG DEPLOYMENT:** *Do not install equipment or route wiring in the deployment path of an airbag. Failure to observe this warning will reduce the effectiveness of the airbag or potentially dislodge the equipment, causing serious injury or death.*

**NOTE:** Plan all cable routing before the installation.

**DRILLING PRECAUTIONS:** *When drilling holes, check the area you are drilling into to be sure you do not damage vehicle components. All drilled holes should be deburred and all sharp edges should be smoothed. All wire routings going through drilled holes should be protected by a grommet or convolute/split loom tubing.*

#### **NOTICE**

**THREAD DAMAGE AND GALLING:** *To prevent thread damage and galling, anti-seize lubricant must be used on all stainless steel fasteners.*

To install the brackets:

1. Attach the headliner bracket to the XStream lighthead using the two supplied #8 screws. Do not overtighten them.

2. Place the XStream lighthead into the selected mounting location. The bracket can be bent for proper alignment. Mark the location of two mounting holes.
3. Drill two 0.159 in holes (#21 drill).
4. Secure the XStream lighthead using the two supplied #10 pan-head screws.
5. Complete the wiring according to the instructions supplied with the lighthead.

**Figure 1** Light attached through headliner

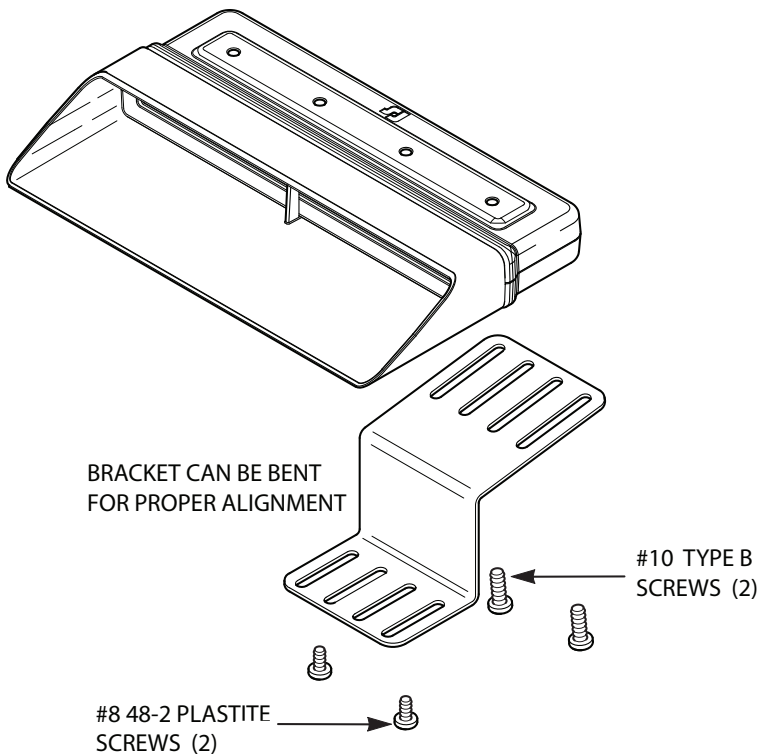

### **⚠ WARNING**

***LIGHT HAZARD: To be an effective warning device, an emergency warning system produces bright light that can be hazardous to your eyesight when viewed at a close range. Do not stare directly into the lights at a close range or permanent damage to your eyesight may occur.***

4. Test the lights for proper operation.

### **Getting Technical Support and Service**

The Federal Signal factory provides technical assistance with any problems that cannot be handled locally. Any units returned to Federal Signal for service, inspection, or repair must be accompanied by a Return Material Authorization (RMA). Obtain a RMA from a local Distributor or Manufacturer's Representative. Please provide a brief explanation of the service requested, or the nature of the malfunction.

For technical support and service, visit:

<https://www.fedsig.com/technical-support>

<https://www.fedsig.com/service-centers>