

Solar Power Option

Models: PVS240W-24 and PVS240W-48



Description, Installation, and Operation Manual

Limited Warranty

This product is subject to and covered by a limited warranty, a copy of which can be found at www.fedsig.com/SSG-Warranty. A copy of this limited warranty can also be obtained by written request to Federal Signal Corporation, 2645 Federal Signal Drive, University Park, IL 60484, email to info@fedsig.com or call +1 708-534-3400.

This limited warranty is in lieu of all other warranties, express or implied, contractual or statutory, including, but not limited to the warranty of merchantability, warranty of fitness for a particular purpose and any warranty against failure of its essential purpose.



FEDERAL SIGNAL
Safety and Security Systems

2645 Federal Signal Drive
University Park, Illinois 60484

www.fedsig.com

Customer Support 800-548-7229 • +1 708 534-3400
Technical Support 800-524-3021 • +1 708 534-4790

All product names or trademarks are properties of their respective owners.

Contents

Safety Messages	6
General Description	9
Overview	9
Features.....	9
Specifications	9
Installation	10
Installing the Solar Panel Bracket	10
Required Equipment	10
Side Pole Installation	10
Top-of-Pole Installation	15
Power Supply and Wiring	17
Power Supply	17
Wiring the 48 V Junction Box.....	17
Wiring the 24 V Junction Box.....	18
Wiring the 24 V Junction Box (110 W Modules, three conductors).....	21
Wiring the 24 V Junction Box (110 W Modules, four-wire).....	22
Solar Regulator Settings (24 Vdc Operation)	25
Solar Configuration Only	25
Solar Panels and AC Battery Charger	27
Programming the PS-30M	28
Getting Technical Support and Service	30

Figures

Figure 1 Placement of 65+ W Module (Top View)	13
Figure 2 Side Pole Mount (65+ W Modules)	14
Figure 3 Side Pole Mount (110 W Modules)	15
Figure 4 Top-of-Pole Mount	16
Figure 5 Module Wiring (Back View).....	19
Figure 6 Wiring PVS220W Option	20
Figure 7 Wiring PVS240W Option	21
Figure 8 Module Wiring 110 W Panels	23
Figure 9 Wiring PVS220W Option	24
Figure 10 PS-30M Solar Regulator.....	25
Figure 11 Solar Only for AGM and GEL Batteries.....	26
Figure 12 Solar Only for Lead Acid Batteries	26
Figure 13 Solar Panel and AC Battery Charger for AGM, GEL, or Lead Acid Batteries.....	27
Figure 14 Final Assembly Solar Bracket 65+ W (Four Panels).....	31
Figure 15 Final Assembly Solar Bracket Side Mount 110 W (Two Panels).....	32
Figure 16 Final Assembly Solar Bracket Top-of-Pole Mount 110 W (Two Panels)	33
Figure 17 DCB and DCFCB Solar Wiring.....	34
Figure 18 DCFCTB Solar Wiring.....	35
Figure 19 One-Way Solar UltraVoice Wiring Diagram	36
Figure 20 Two-Way Solar UltraVoice Wiring Diagram	37
Figure 21 Two-Way Primary AC with Solar UltraVoice Wiring Diagram	38
Figure 22 Two-Way Primary Solar with AC UltraVoice Wiring Diagram	39
Figure 23 Hawaii UltraVoice Wiring Diagram	40
Figure 24 Solar Assembly for the UltraVoice	41
Figure 25 Solar Assembly for the DC Series Siren Control System.....	42

Tables

Table 1 Side Pole Mount	9
Table 2 Top-of-Pole Mount	9
Table 3 Required Tools	10
Table 4 Recommended AGM and GEL Batteries	25
Table 5 Lead Acid Batteries	26
Table 6 Settings for Switches	27

Safety Messages

⚠ WARNING

It is important to follow all instructions shipped with this product. This device is to be installed by trained personnel who are thoroughly familiar with the country's electric codes and will follow these guidelines as well as local codes and ordinances, including any state or local noise-control ordinances.

Listed below are important safety instructions and precautions you should follow:

Important Notice

Federal Signal reserves the right to make changes to devices and specifications detailed in the manual at any time in order to improve reliability, function, or design. The information in this manual has been carefully checked and is believed to be accurate; however, no responsibility is assumed for any inaccuracies.

Publications

Federal Signal recommends the following publications from the Federal Emergency Management Agency for assistance with planning an outdoor warning system:

- The "Outdoor Warning Guide" (CPG 1-17)
- "Civil Preparedness, Principles of Warning" (CPG 1-14)
- FEMA-REP-1, Appendix 3 (Nuclear Plant Guideline)
- FEMA-REP-10 (Nuclear Plant Guideline).

Planning

- If suitable warning equipment is not selected, the installation site for the siren is not selected properly, or the siren is not installed properly, it may not produce the intended optimum audible warning. Follow Federal Emergency Management Agency (FEMA) recommendations.
- If sirens are not activated in a timely manner when an emergency condition exists, they cannot provide the intended audible warning. It is imperative that knowledgeable people, who are provided with the necessary information, be available at all times to authorize the activation of the sirens.
- When sirens are used out of doors, people indoors may not be able to hear the warning signals. Separate warning devices or procedures may be needed to warn people indoors effectively.
- The sound output of sirens is capable of causing permanent hearing damage. To prevent excessive exposure, carefully plan siren placement, post warnings, and restrict access to areas near sirens. Review and comply with any local or state noise control ordinances as well as OSHA noise exposure standards, regulations, and guidelines.
- Activating the sirens may not result in people taking the desired actions if those to be warned are not properly trained about the meaning of siren sounds. Users should follow FEMA recommendations and instruct those to be warned of corrective actions to be taken.

- After installation, service, or maintenance, test the siren system to confirm that it is operating properly. Test the system regularly to confirm that it will be operational in an emergency.
- If future service and operating personnel do not have these instructions to refer to, the siren system may not provide the intended audible warning and service personnel may be exposed to death, permanent hearing loss, or other bodily injuries. File these instructions in a safe place and refer to them periodically. Give a copy of these instructions to new recruits and trainees. Also give a copy to anyone who is going to service or repair the siren.

Installation and Service

- Electrocutation or severe personal injury can occur when performing various installation and service functions such as making electrical connections, drilling holes, or lifting equipment. Therefore, only experienced and qualified electricians should install this product in compliance with national, state, and any other applicable codes, ordinances, and regulations. Perform all work under the direction of the installation or service crew safety foreman.
- The sound output of sirens is capable of causing permanent hearing damage. To prevent excessive exposure, carefully plan siren placement, post warnings, and restrict access to areas near the sirens. Sirens may be operated from remote control points. Whenever possible, disconnect all siren power, including batteries, before working near the siren. Review and comply with any local or state noise control ordinances as well as OSHA noise exposure regulations and guidelines.
- After installation or service, test the siren system to confirm that it is operating properly. Test the system regularly to confirm that it will be operational in an emergency.
- If future service and operating personnel do not have these instructions to refer to and are not properly trained, the system may not provide the intended audible warning, and service personnel may be exposed to hazards that could result in death, permanent hearing loss, or other bodily injuries. File these instructions in a safe place and refer to them periodically. Give a copy of these instructions to recruits and trainees. Also give a copy to anyone who is going to service or repair the siren.

Operation

Failure to understand the capabilities and limitations of your siren could result in permanent hearing loss, other serious injuries, or death to persons too close to the sirens when you activate them or to those you need to warn. Carefully read and thoroughly understand all safety notices in this manual and all operations-related items in all instruction manuals shipped with the equipment. Thoroughly discuss all contingency plans with those responsible for warning people in your community, company, or jurisdiction. A well-written contingency plan document is recommended.

Solar modules generate DC electricity when exposed to light. Exposure to this voltage can result in serious injury or even death. Follow all safety precautions.

To stop the production of electricity, cover panel surfaces with opaque material while working on the system. Avoid touching terminals and/or wire ends until connections are made.

Hazard Classification

Federal Signal uses signal words to identify the following:

⚠ DANGER

DANGER indicates a hazardous situation which, if not avoided, will result in death or serious injury.

⚠ WARNING

WARNING indicates a hazardous situation which, if not avoided, could result in death or serious injury.

⚠ CAUTION

CAUTION indicates a hazardous situation which, if not avoided, could result in minor or moderate injury.

NOTICE

NOTICE is used to address practices not related to physical injury.

Read and understand the information contained in this manual before attempting to install or service the siren.

Pay careful attention to notices located on the equipment.

General Description

Overview

This manual describes how to install the Solar Power option.

The Solar Power option provides an all-inclusive solar powering option for all outdoor sirens. Solar powering batteries is an efficient and economical method of powering remote sirens, alerting or control equipment. Applications include, but are not limited to, remote tsunami sirens, muster stations, and tornado sirens.

The PVS240W-24 and PVS240W-48 provide 240 watts of power for charging batteries in 24 or 48 Vdc applications. These systems are equipped with solar regulators for accurate control, protection, and solar panel monitoring. These kits use four 65+ watt highly efficient solar panels, each with junction boxes to allow ease of wiring.

The mounting hardware is lightweight and high strength aluminum, able to withstand wind loads up to 170 mph. The kit includes thirty feet of cable to allow wiring from the panels to the Battery Cabinet. The solar regulators support gel, sealed, or flooded batteries with temperature compensation to extend battery life and improve system performance. Federal Signal determines the proper direction and tilt for each solar application based on location. Federal Signal recommends gel batteries for solar applications.

NOTE: The PVS220W-24 and PVS220W-48 are no longer available for sale. They are included in this manual for maintenance purposes only.

Features

The Solar Power models have the following features:

- Enables remote/unwired deployment of sirens
- Solar power provides continuous charging of batteries
- Radio connectivity for two-way activation and control
- Eliminates expensive trenching of power to remote sites
- Supports mechanical or electronic sirens
- Allows 25 to 60° of tilt for solar optimization
- 24 or 48 Vdc operation
- Wind loads up to 170 mph

Specifications

Table 1 Side Pole Mount

Net Weight	115 lb (52 kg)
Shipping Weight	153 lb (69 kg)

Table 2 Top-of-Pole Mount

Net Weight	112 lb (51 kg)
Shipping Weight	150 lb (68 kg)

Installation

Installing the Solar Panel Bracket

⚠ DANGER

SHOCK HAZARD: *Electrocution or severe personal injury can occur when making electrical connections, drilling holes, or lifting equipment. Therefore, experienced electricians, per national and local electrical codes, acting under the installation crew safety foreman’s direction, should perform the installation.*

Most bracket installations are one of two types: Side Pole Mount or Top Pole Mount. These two configurations make it possible to provide solar power in almost any situation. If the installations in this manual are not suitable, it may be practical to modify one of the configurations.

For best results, the solar modules must face true south. Consult FEMA CPG 1-17 and CPG 1-14 and your local Federal Signal representative to place your outdoor warning equipment properly.

Required Equipment

You need the following equipment.

Table 3 Required Tools

Checklist	Required Tools
	Large flat head screwdriver
	Medium flat head screwdriver
	Narrow (3/16-in) flat head screwdriver
	Medium cross head screwdriver
	Socket driver set with 7/16-in, 9/16-in and 3/4-in sockets
	7/16-in open end wrench
	9/16-in open end wrench
	Adjustable wrench
	Wire cutters
	Needle nose pliers
	Wire strip and crimp tool
	Electric drill with 1/4-in drill bit
	Utility knife
	Measuring tape

Side Pole Installation

The bracket is typically mounted on a Class 2 utility pole (ANSI-type wooden pole or equivalent) with a minimum horizontal ground stress rating of 3,700 pounds (1678 kg). Ensure that soil loads will conform to this size utility pole.

NOTE: Certain soil conditions may require guying for the pole. Check with the proper building authorities.

To install a side pole mount solar bracket onto a wooden utility pole:

1. Uncrate and identify the various parts. Use an empty box as a platform to protect the assembly and modules from damage.
2. Place the solar modules face down with their junction boxes toward the center for the modules or toward the top for the 110-watt panels.
3. Assemble the solar bracket onto the solar modules per the final assembly drawing. Apply thread-locking compound to all fastening hardware to ensure a secure assembly.
4. Find the desired elevation on the pole. For best results, the solar modules must face true south. Mark the eight mounting holes on the pole for the bracket.
5. Drill a 3/8-inch pilot hole at each of the locations. Drill each hole at least 3-1/2 inches deep.
6. Using eight 1/2-inch stainless steel lag screws (minimum of 5 inches in length) or two sections of 3/4-inch wide stainless steel strapping, secure the solar bracket onto the pole.
7. Locate your site and find the latitude of your location. For the Northern Hemisphere, add or set the tilt angle at the value specified in the following table.

Latitude Range	Tilt Angle
90° to 60°	60°
60° to 25°	+15°
25° to 20°	+5°
20° to 0°	25°

NOTICE

Tilt angles are limited to a minimum of 25° and a maximum of 60°.

8. Find the vertical distance Y for your setup from the tilt angle charts.

For any other type of pole, such as a galvanized steel pole, install the side mount solar bracket as follows:

1. Uncrate and identify the various parts. Use an empty box as a platform to protect the assembly and modules from damage.
2. Start by placing the solar modules face down with their junction boxes toward the center for the modules or toward the top for the 110-watt panels.
3. Assemble the solar bracket onto the solar modules per the final assembly drawing. Apply thread-locking compound to all fastening hardware to ensure a secure assembly.
4. Find the desired elevation on the pole. For best results, the solar modules must face true south. Mark the two placement locations on the pole for the bracket.
5. Secure the solar bracket by clamping it onto the pole using two sections of 3/4-inch wide stainless steel strapping and the tilt angle charts.
6. Locate your site and find the latitude of your location. For the Northern Hemisphere, add or set the tilt angle at the following table.

Latitude Range	Tilt Angle
90° to 60°	60°
60° to 25°	+15°
25° to 20°	+5°
20° to 0°	25°

NOTICE

Tilt angles are limited to a minimum of 25° and a maximum of 60°.

7. Find the vertical distance Y for your setup from the tilt angle charts.

Figure 1 Placement of 65+ W Module (Top View)

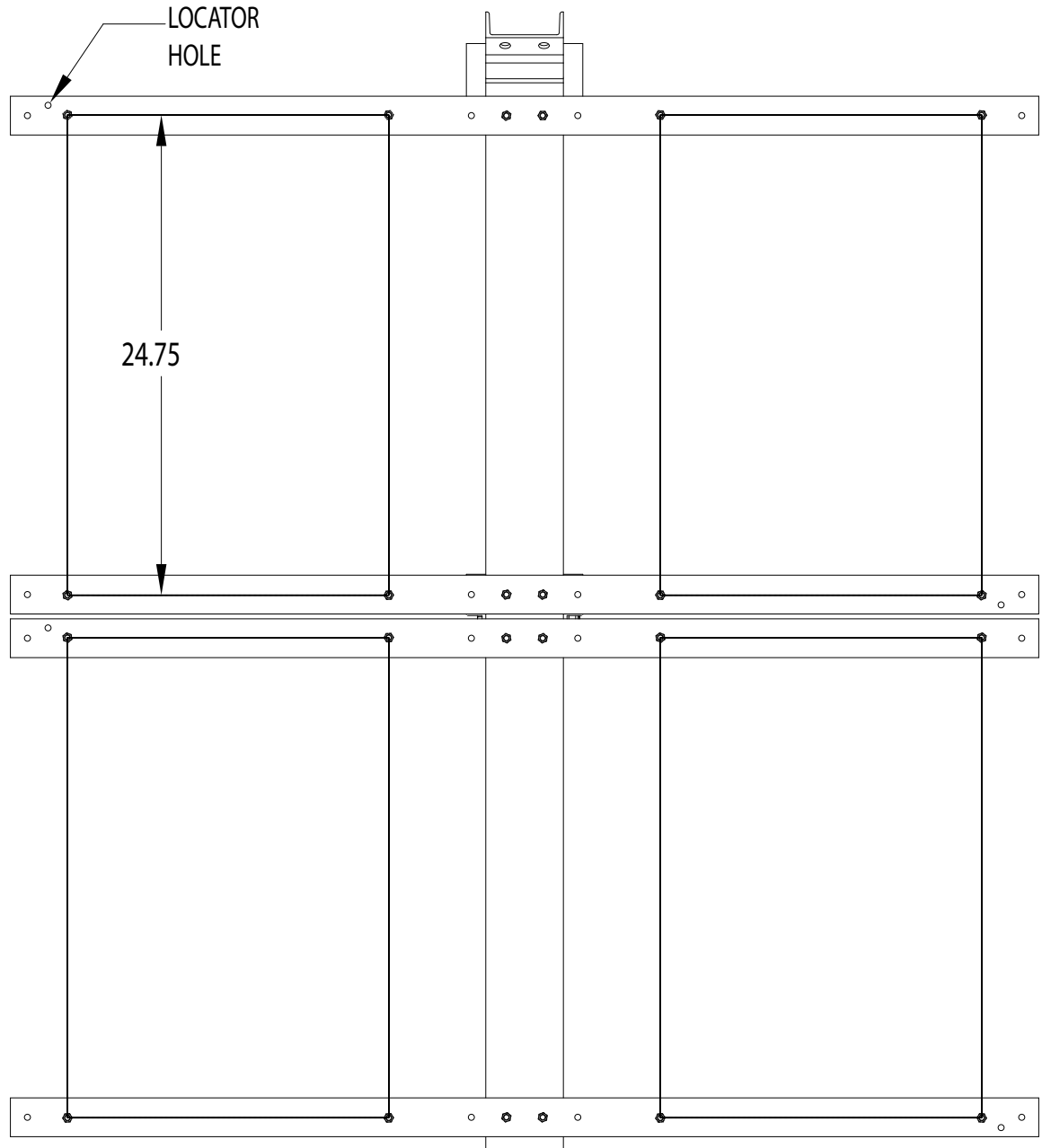
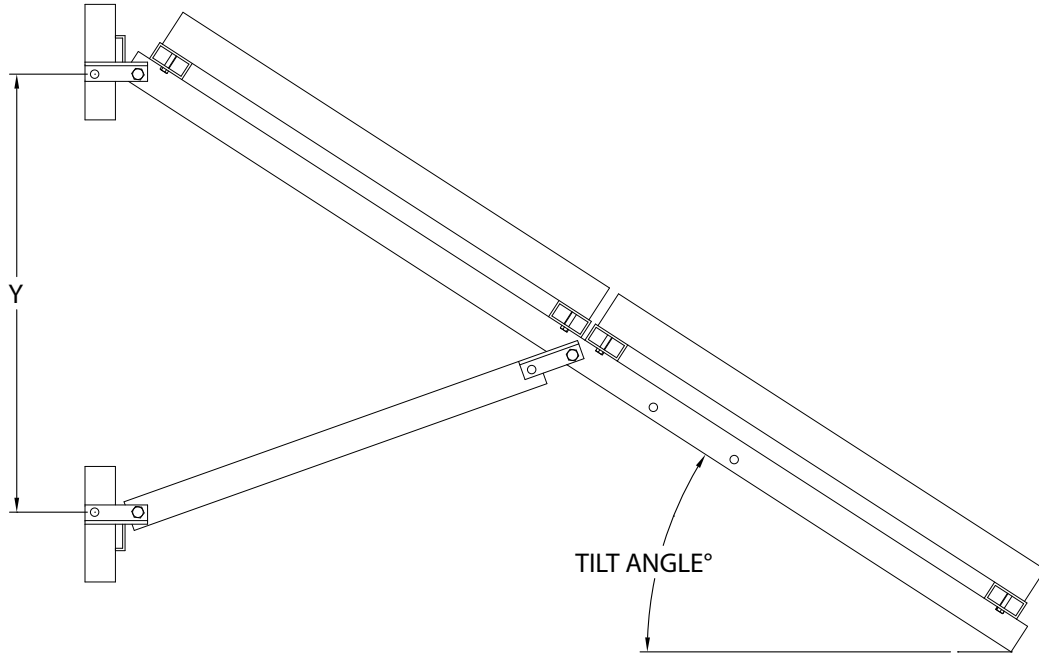

Figure 2 Side Pole Mount (65+ W Modules)



291355C

Tilt Angle from horizontal	Vertical Distance Y	Hole Number
25°	15.0 in (38.1 cm)	1
30°	20.5 in (52.1 cm)	1
35°	26.0 in (66.0 cm)	1
40°	26.0 in (66.0 cm)	2
45°	31.5 in (80.0 cm)	2
50°	33.5 in (85.1 cm)	3
55°	42.5 in (108.0 cm)	3
60°	48.0 in (121.9 cm)	3

Figure 3 Side Pole Mount (110 W Modules)

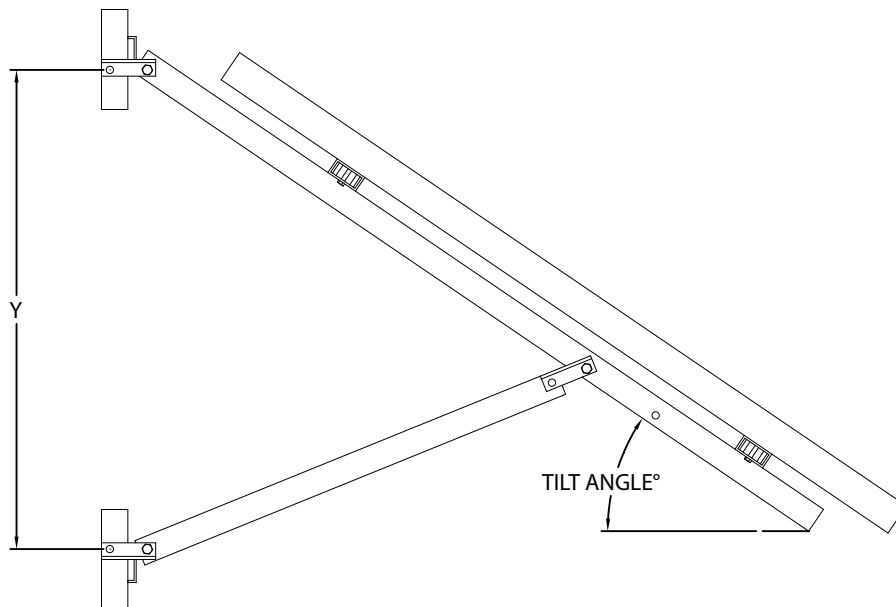

Tilt Angle from horizontal	Vertical Distance Y	Hole Number
30°	23.0 in (58.4 cm)	1
35°	30.0 in (76.2 cm)	1
40°	28.8 in (73.0 cm)	2
45°	37.5 in (95.3 cm)	2
55°	48.0 in (121.9 cm)	1
60°	51.3 in (130.2 cm)	1

Top-of-Pole Installation

To install a top-of-pole solar bracket:

1. Uncrate and identify the various parts. Use an empty box as a platform to protect the assembly and modules from damage.
2. Start by placing the solar modules face down with their junction boxes toward the center for the modules or toward the top for the 110-watt panels.
3. Assemble the solar bracket onto the solar modules per the final assembly drawing. Apply thread-locking compound to all fastening hardware to ensure a secure assembly.

4. Locate your site and find the latitude of your location. For the Northern Hemisphere, add or set the tilt angle at the value specified in the following table.

Latitude Range	Tilt Angle
90° to 60°	50°
60° to 25°	+15°
25° to 20°	+5°
20° to 0°	25°

NOTICE

Tilt angles are limited to a minimum of 25° and a maximum of 50°.

5. Find the vertical distance Y for your setup from the tilt angle chart. For best results, the solar modules must face true south.
6. Using the stainless steel u-bolt provided, secure the solar bracket onto the pole.

Figure 4 Top-of-Pole Mount

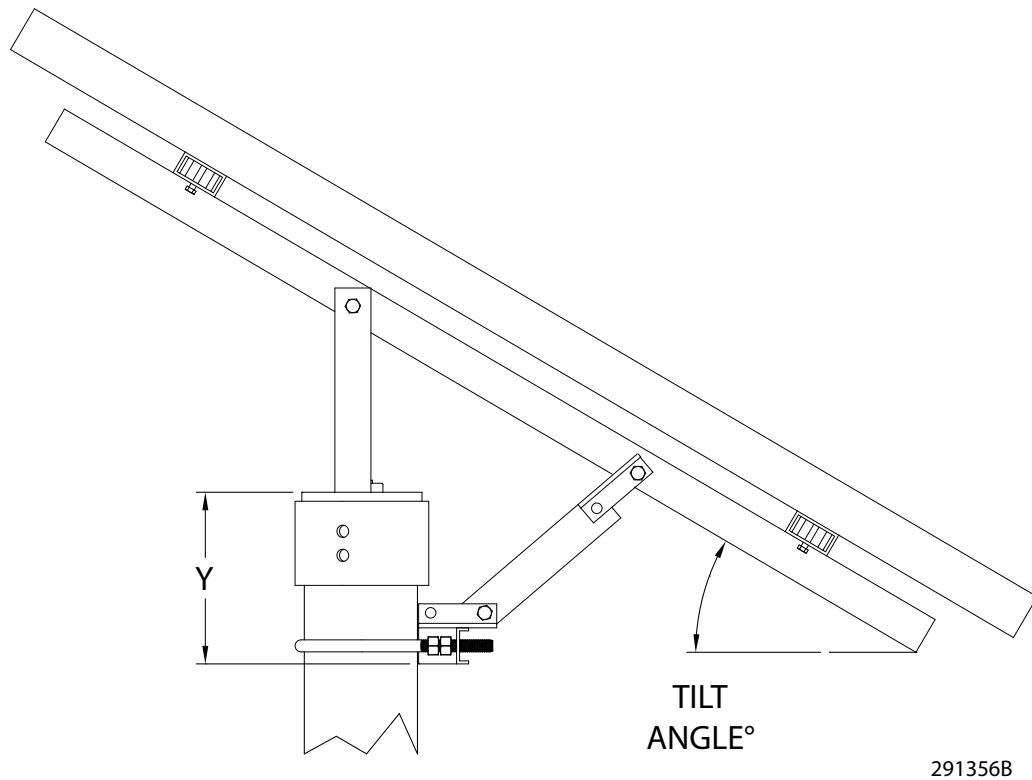

291356B

Tilt Angle from horizontal	Vertical Distance Y
25°	5.0 in (12.7 cm)
30°	5.5 in (14.0 cm)
35°	6.3 in (15.9 cm)
40°	7.0 in (17.8 cm)
45°	7.5 in (19.1 cm)
50°	7.8 in (19.7 cm)

Power Supply and Wiring

Power Supply

Connect four 65+ watt, 12-volt solar modules in series to supply a 48 Vdc power supply for the 2001-130, Equinox, 508-128, and Eclipse8 electro-mechanical siren controls.

Connect four 65+ watt, 12-volt solar modules in series/parallel to supply a 24 Vdc power supply for the UltraVoice® Electronic Siren Controller.

Connect two 110 watt, 12-volt solar modules in series/parallel to supply a 24 Vdc power supply for the UltraVoice® Electronic Siren Controller.

Wiring the 48 V Junction Box

To wire the 48-volt junction box for the 65+ watt modules:

1. Open the module junction box covers.
2. Knock out the appropriate junction box holes in the modules to allow the addition of cable clamps. An additional knockout is required for the array output wires leading from the array to the Control Cabinet.
3. Coat the module terminals with NO-OX-ID® or an equivalent corrosion inhibitor to prevent corrosion.
4. Cut the three-conductor cable 8-foot length (2.44 m) into three 32-inch (81.28 cm) sections.
5. Connect the black wires from the three-conductor cable sections as follows:
 - Negative (-) terminal of module A to positive (+) terminal of module B
 - Negative (-) terminal of module B to positive (+) terminal of module C
 - Negative (-) terminal of module C to positive (+) terminal of module D
6. Run one side of the two-conductor PV output cable 30-foot length (9.144 m) through the cable clamp to the module D junction box. Connect the black wire to the negative (-) terminal and butt splice the red wire to the red wire from the three-conductor cable within the junction box. Use the wire tie wraps provided to secure the output cable to the bracket.
7. Measure the voltage between the red (+) and black (-) wires at the end of the PV output cable with the modules exposed to sunlight. If the wiring is correct, the voltage measures between 60 and 92 volts. If the voltage is not in this range, check the wire connections to ensure all steps were followed.

8. Close the junction box covers.
9. Run the other side of the two-conductor PV output cable (30-foot length) down the pole to the Control Cabinet. Use the wire tie wraps provided to secure the output cable. Form a drip loop where the cable enters the Control Cabinet. Run the cable through the 1/2-inch NPT aluminum cord grip provided and connect it to the solar regulator using the spade terminals.
10. Installation is now complete.

Wiring the 24 V Junction Box

To wire the 24-volt junction box for the 65+ watt modules:

1. Open the module junction box covers.
2. Knock out the appropriate junction box holes in the modules to allow the addition of cable clamps. An additional knockout will be required for the array output wires leading from the array to the Control Cabinet.
3. Coat the module terminals with NO-OX-ID[®] or an equivalent corrosion inhibitor to prevent corrosion.
4. Cut a 32-inch (81.3 cm) section from the three-conductor cable 8-foot length (2.4 m).
5. Connect the white wire from the three-conductor section as follows:
 - Negative (-) terminal of module A to positive (+) terminal of module B
 - Negative (-) terminal of module C to positive (+) terminal of module D
6. Run the two-conductor PV output cable 30-foot length (9.144 m) through the cable clamp to the module D junction box. Connect the black wire to the negative (-) terminal and butt splice the red wire to the red wire from the three-conductor cable within the junction box. Use the wire tie wraps provided to secure the output cable to the bracket.
7. Measure the voltage between red (+) and black (-) wires at the end of the PV output cable with the modules exposed to sunlight. If the wiring is correct, the voltage measures between 30 and 46 volts. If the voltage is not in this range, check the wire connections to ensure all steps were followed.
8. Close the junction box covers.
9. Run the two-conductor PV output cable (30-foot length) down the pole to the Control Cabinet. Use the wire tie wraps provided to secure the output cable. Form a drip loop where the cable enters the Control Cabinet. Run the cable through the 1/2-inch NPT aluminum cord grip provided and connect it to the solar regulator using the spade terminals.
10. Installation is now complete.

Figure 5 Module Wiring (Back View)

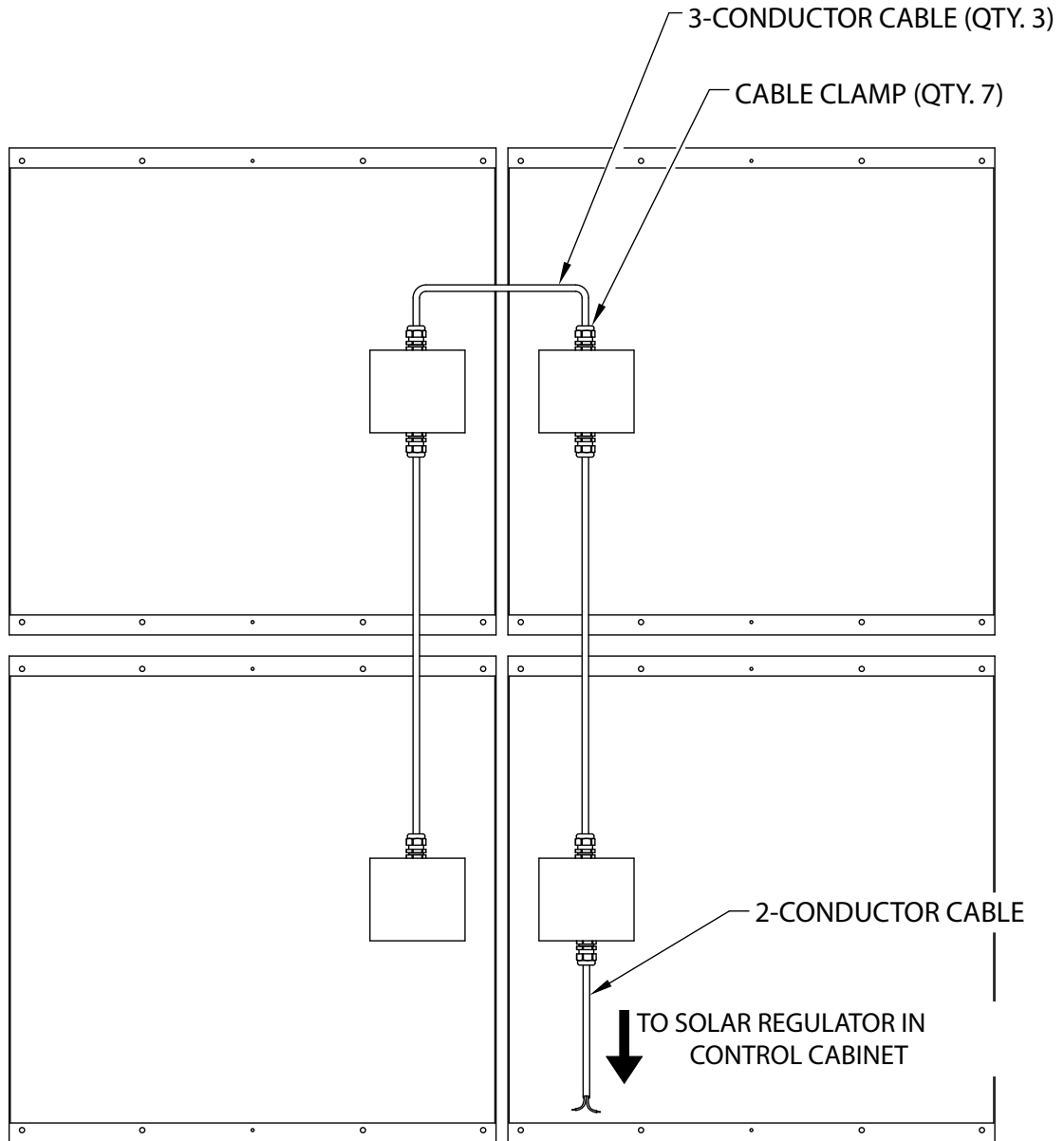

(BACK VIEW)
MODULE WIRING

291357B

Figure 6 Wiring PVS220W Option

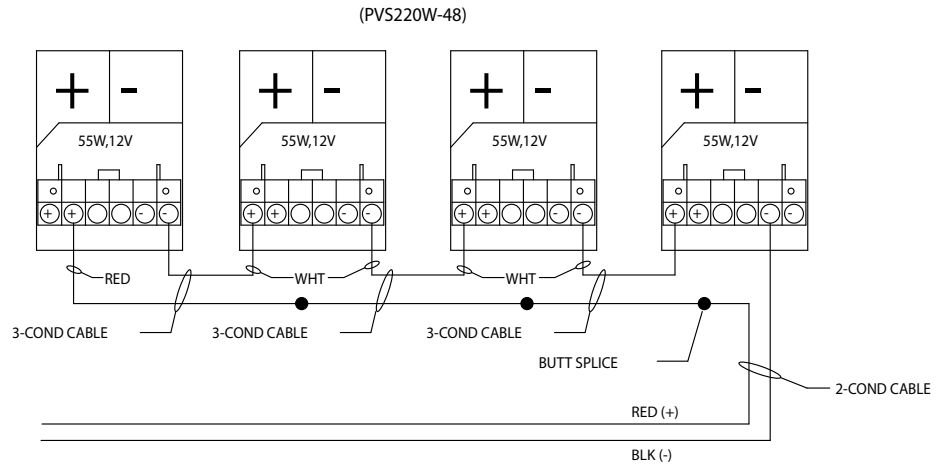
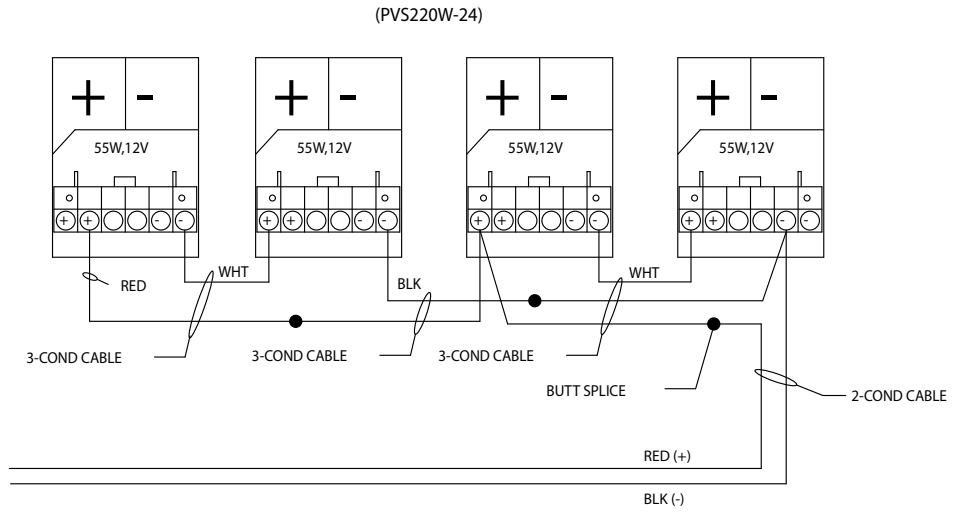

291358B

Figure 7 Wiring PVS240W Option

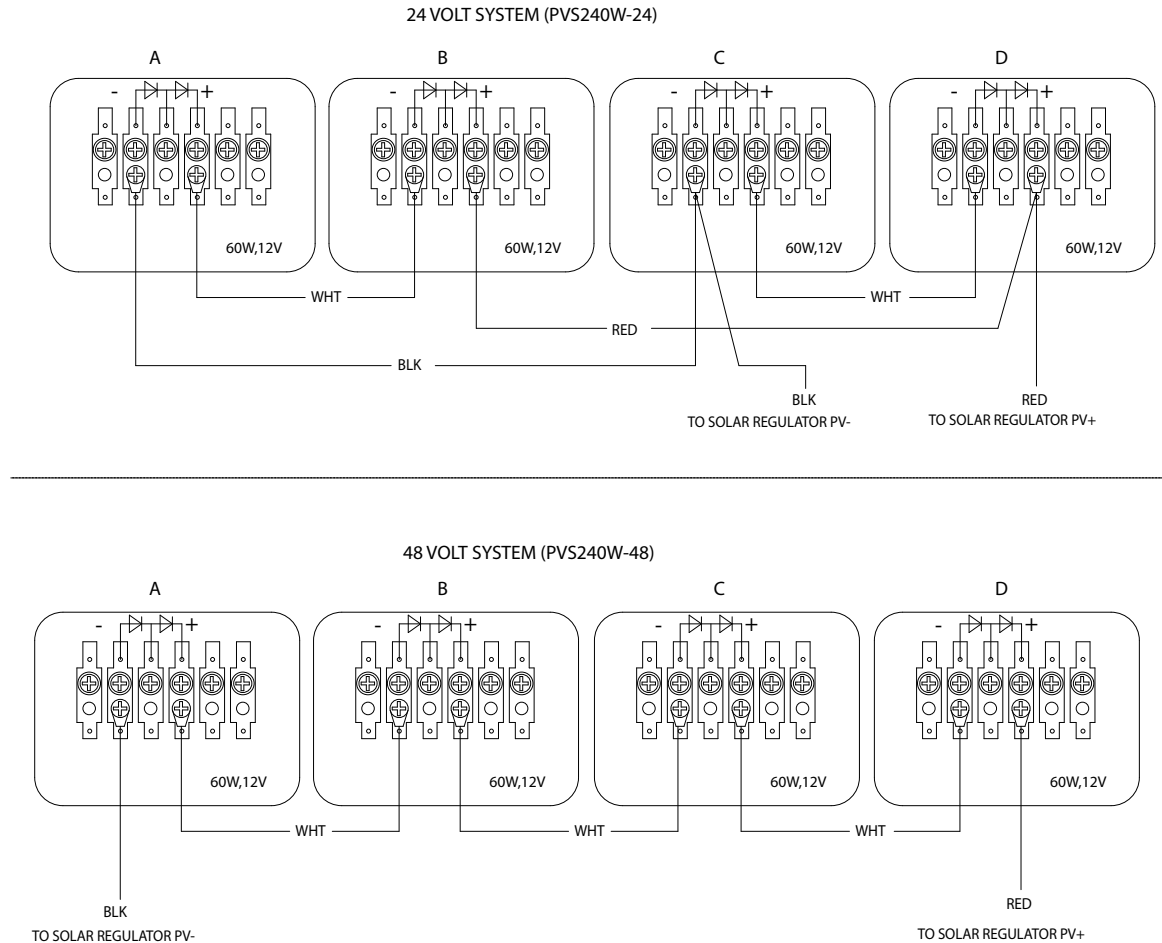

Wiring the 24 V Junction Box (110 W Modules, three conductors)

To wire the 24-volt junction box for the 110-watt modules, three conductors:

1. Open the module junction box covers.
2. Knock out the appropriate junction box holes in the modules to allow the addition of cable clamps. An additional knockout will be required for the array output wires leading from the array to the Control Cabinet.
3. Coat the module terminals with NO-OX-ID® or an equivalent corrosion inhibitor to prevent corrosion.
4. Connect the white wire from the short three-conductor cable 3-foot length (91.44 cm) as follows:
 - Negative (-) terminal of module A to positive (+) terminal of module B
5. Run the long three-conductor PV output cable 60-foot length (18.3 m) through the cable clamp to the module B junction box. Connect the black wire to the negative (-) terminal and butt splice the red wire to the red wire from the three-conductor cable within the junction box. Use the wire tie wraps provided to secure the output cable to the bracket.

6. Measure the voltage between the red (+) and black (-) wires at the end of the PV output cable with the modules exposed to sunlight. If the wiring is correct, the voltage measures between 30 and 46 volts. If the voltage is not in this range, check the wire connections to ensure all steps were followed.
7. Close the junction box covers.
8. Run the three-conductor PV output cable (60-foot length) down the pole to the Control Cabinet. Use the wire tie wraps provided to secure the output cable. Form a drip loop where the cable enters the Control Cabinet. Run the cable through the 1/2-inch NPT aluminum cord grip provided and connect it to the solar regulator using the spade terminals. Check the wire connections are made per diagram “Figure 23 Hawaii UltraVoice Wiring Diagram” on page 40.
9. Installation is now complete.

Wiring the 24 V Junction Box (110 W Modules, four-wire)

To wire the 24-volt junction box for the 110-watt modules, four-wire Hawaii:

1. Open the module junction box covers.
2. Knock out the appropriate junction box holes in the modules to allow the addition of cable clamps. An additional knockout will be required for the array output wires leading from the array to the Control Cabinet.
3. Coat the module terminals with NO-OX-ID® or an equivalent corrosion inhibitor to prevent corrosion.
4. Run the wires 60-foot length (18.29 m) for the top mount or 30-foot (9.14 m) for the side mount, with an additional 3-foot length (91.44 cm) through the cable clamp to the module B junction box. Connect the shorter wires to the positive (+) and negative (-) terminals of module B. Run the longer wires out and connect them to the terminals of module A. Use the wire tie wraps provided to secure the output cable to the bracket.
5. Measure the voltage between the two sets of red (+) and black (-) wires at the end of the PV output wires with the modules exposed to sunlight. If the wiring is correct, the voltage on each set of wires measures between 15 and 23 volts. With a jumper installed on terminal blocks in the UV Control Cabinet, the series combination of the two modules measures between 30 and 46 Vdc. If either of these voltage values is not obtained, check the wire connections are made per diagram “Figure 23 Hawaii UltraVoice Wiring Diagram” on page 40.
6. Close the junction box covers.
7. Run the wires down the pole to the Control Cabinet. Use the wire tie wraps provided to secure the output cable. Form a drip loop where the cable enters the Control Cabinet. Run the cable through the 1/2-inch NPT aluminum cord grip provided and connect it to the solar regulator using the spade terminals.
8. Installation is now complete.

Figure 8 Module Wiring 110 W Panels

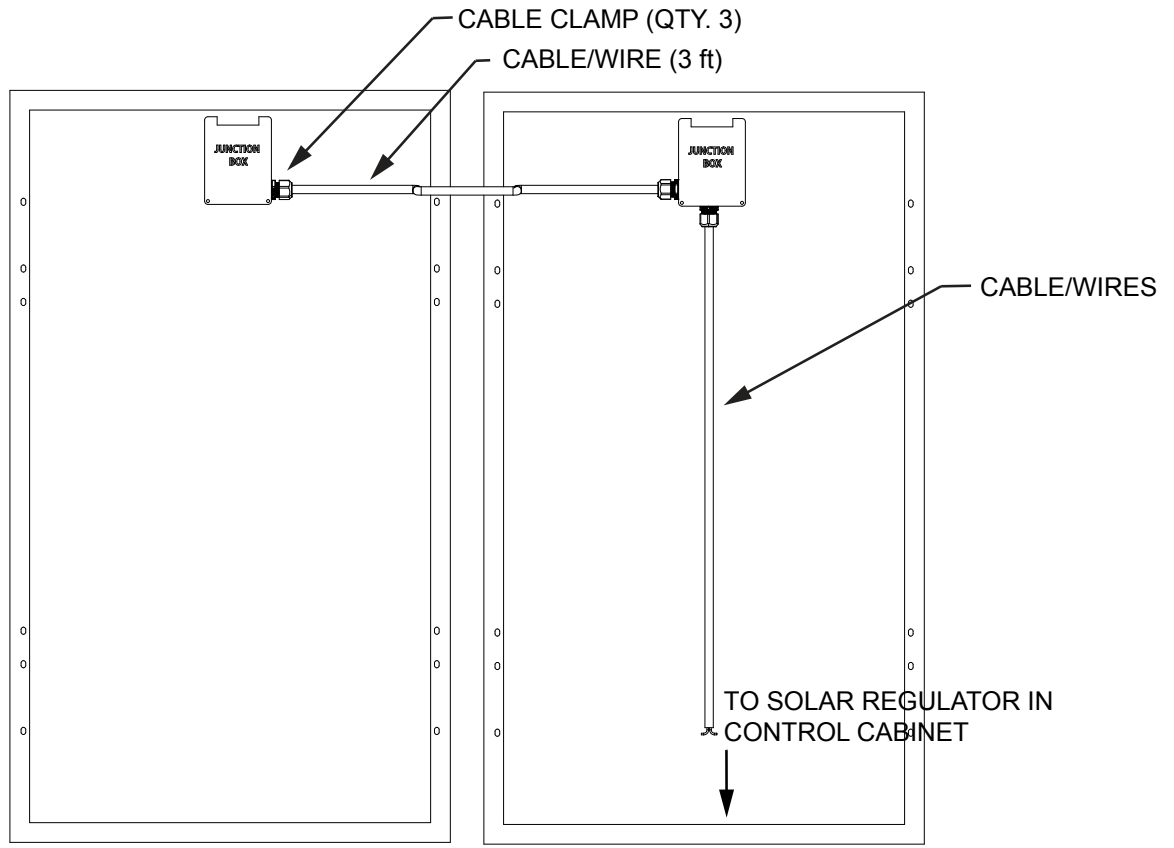

(BACK VIEW)
MODULE WIRING
110 W PANELS

Figure 9 Wiring PVS220W Option

24 VOLT SYSTEM: 288996 (PVS220W-24)

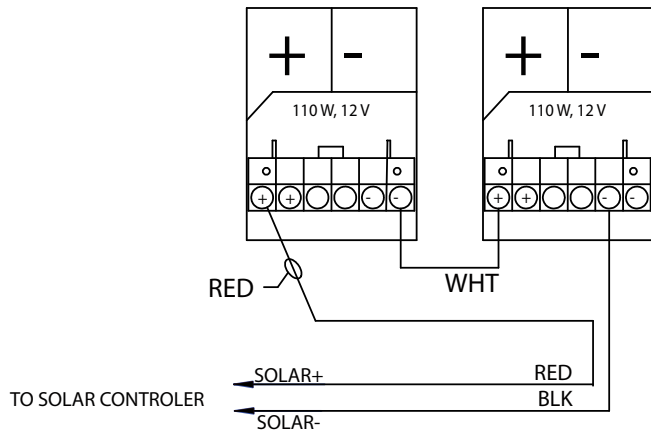

24 V STANDARD VERSION WIRING

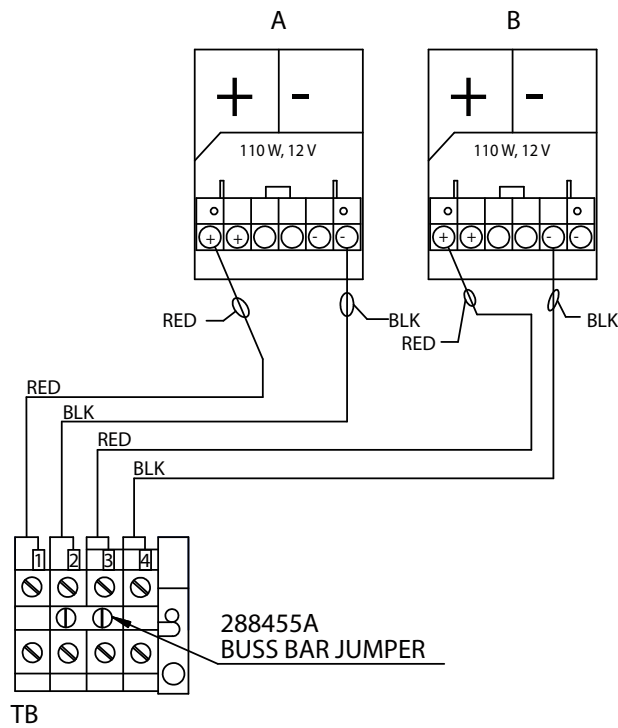

24 V HAWAII VERSION WIRING

Solar Regulator Settings (24 Vdc Operation)

Federal Signal equipment can operate in solar only or in a multi-power configuration (by using Solar Panels and an AC Battery Charger). For the Morningstar® ProStar PS-30M Solar Regulator, Federal Signal recommends the following settings for solar-only configuration. Make these settings by removing the front cover and adjusting the DIP switch block located on the bottom right of the PS-30M Solar Regulator.

Figure 10 PS-30M Solar Regulator



Solar Configuration Only

See “Figure 20 Two-Way Solar UltraVoice Wiring Diagram” on page 37 regarding charger sense wiring for solar only configuration.

When used as solar only, the following settings are recommended for the PS-30M Solar Regulator. The settings are dependent on the battery type. Remove power before changing the switch settings.

NOTE: If you are not using the batteries listed in Table 4 or Table 5, see “Table 6 Settings for Switches” on page 27 for guidance.

The following table lists the recommended batteries.

Table 4 Recommended AGM and GEL Batteries

Federal Signal Part Number	Description
15500007	MK Model 8A24DT, 78 Ah at C/20, Size 24
15500007-01	MK Model 8A27DT, 92 Ah at C/20, Size 27
15500007-02	MK Model 8A31DT, 97.6 Ah at C/20, Size 31
15500007A-03	GEL 73 Ah Model 8G24
15500007A-04	GEL 88 Ah Model 8G27
15500007A-05	GEL 97 Ah Model 8G31

Solar Regulator Settings (24 Vdc Operation)

For the AGM and GEL batteries (see Table 4), set the DIP switches as shown in Figure 11.

Figure 11 Solar Only for AGM and GEL Batteries

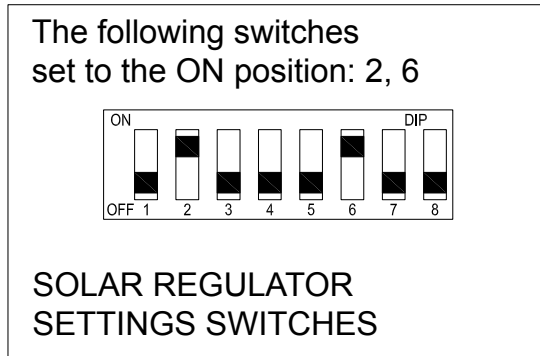

Table 5 Lead Acid Batteries

Federal Signal Part Number	Size	Manufacturer	Model	Capacity at C/20
IK-BATT-STD	Size 24	FVP	Model DC24-6	82 Ah
IK-BATT-EXT	Size 31	Delco	Model S2000	105 Ah

For the Lead Acid batteries (see Table 5), set the DIP switches as shown in Figure 12.

Figure 12 Solar Only for Lead Acid Batteries

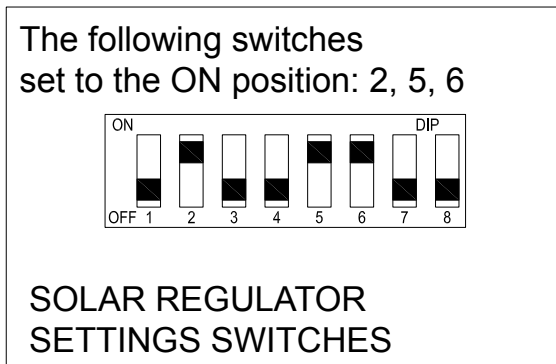

Table 6 Settings for Switches

Settings 4-5-6	Battery Type	Absorp. Stage (V)	Float Stage (V)	Equalize Stage (V)	Absorp. Time (min)	Equalize Time (min)	Equalize Timeout (min)	Equalize Interval (days)
off-off-off	1 - Sealed*	14.0	13.5		150			
off-off-on	2 - Sealed*	14.2	13.5	14.4	150	60	120	28
off-on-off	3 - Sealed*	14.3	13.5	14.6	150	60	120	28
off-on-on	4- AGM/ Flooded	14.4	13.5	15.1	180	120	180	28
on-off-off	5 – Flooded	14.6	13.5	15.3	180	120	180	28
on-off-on	6 – Flooded	14.7	13.5	15.4	180	180	240	28
on-on-on	8 – Custom	Custom	Custom	Custom	Custom	Custom	Custom	Custom

*Sealed battery type includes Gel and AGM batteries.

Solar Panels and AC Battery Charger

See “Figure 22 Two-Way Primary Solar with AC UltraVoice Wiring Diagram” on page 39 regarding charger sense wiring for this mode of operation. The PS-30M Solar Regulator requires a custom file to allow the unit to work properly with the 860000235 (-01) charger in a UV cabinet. If the custom file is not used, the Solar Power option causes the AC charger to go into a fault mode during certain charging modes. The fault is only a nuisance and does not affect system operation.

When used as a combination AC charging with solar backup, the following settings are recommended.

Figure 13 Solar Panel and AC Battery Charger for AGM, GEL, or Lead Acid Batteries

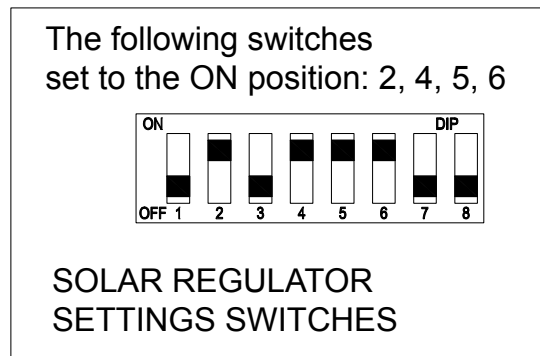

Note regarding custom file:

If servicing the PS-30M Solar Regulator, it may be necessary to load the custom configuration into the unit. Contact Technical Support at techsupport@fedsig.com or 800-524-3021 to obtain a copy of the released configuration file via email.

Programming the PS-30M

The programming requirements of the PS-30M:

- Laptop running Windows®
- Downloading MSView™ at www.morningstarcorp.com/msview/
- USB MeterBus Adapter (UMC-1):
 - www.morningstarcorp.com/products/usb-meterbus-adapter/
 - www.morningstarcorp.com/buy/
- Configuration File: fedsig 8_28_18.pspwm

To program the PS-30M:

1. Load MSView™ on a laptop.
2. Transfer the fedsig 8_28_18.pspwm configuration file to a folder on your computer.
3. Connect the USB MeterBus Adapter (UMC-1) to a USB port on a laptop.
NOTE: Ensure PS-30M has batteries and solar panels are connected before the next step.
4. Connect the USB MeterBus Adapter (UMC-1) to the Serial port of PS-30M (black RJ-12 jack on PS-30M).
5. Open MSView.
6. Select Devices > Search for Connected Devices. PS-30M appears.

Now that connectivity has been established between the MSView software and the PS-30M, upload the configuration file.

To upload the configuration file:

1. Select Tools > Prostar PWM Setup Wizard.

The Warning dialog box appears.

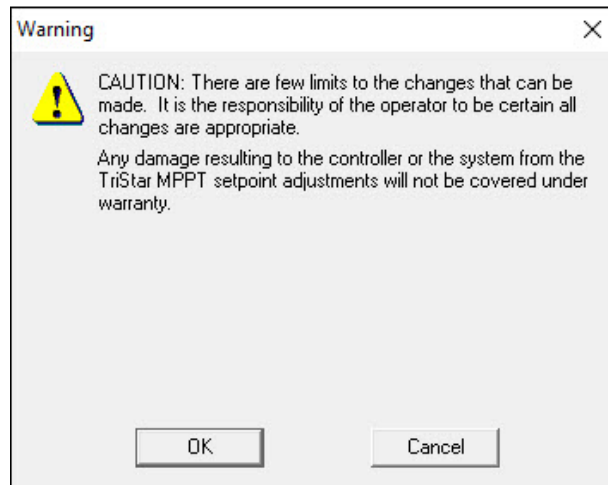

2. Click OK.

The Custom Setpoints Summary window appears.

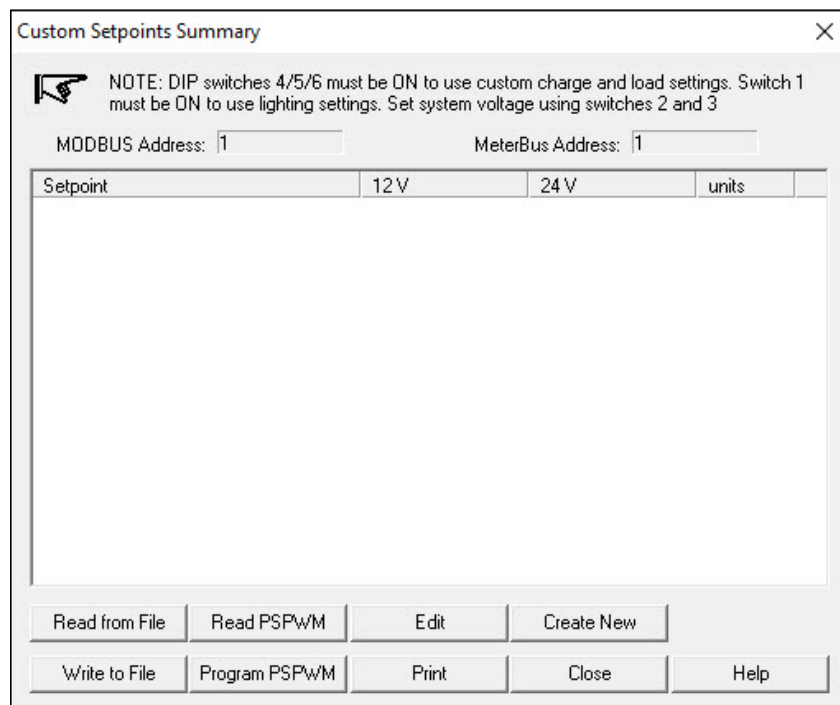

3. Click the Read from File button.
4. Browse to the location where fedsig 8_28_18.pspwm is saved.
5. Select the file and click Open.

You will automatically return to the Custom Setpoints Summary dialog box.

6. Click the Program PSPWM button to load the file.

Getting Technical Support and Service

Now that the new configuration has been loaded, the PS-30M must be power cycled.

To power cycle:

- 1.** Disconnect the batteries from the PS-30M.
- 2.** Wait for 5 seconds.
- 3.** Reconnect the batteries to the battery terminal of the PS-30M.

The PS-30M powers up, and the display shows battery voltages and state of charge.

Getting Technical Support and Service

For technical support, contact:

Federal Signal
Technical Support
Phone: 800-524-3021 or 708-534-4790
Email: techsupport@fedsig.com
www.fedsig.com

For customer support, contact:

Federal Signal
Customer Support
Phone: 800-548-7229 or 708-534-3400 extension 367511
Email: customersupport@fedsig.com
www.fedsig.com

Figure 14 Final Assembly Solar Bracket 65+ W (Four Panels)

ITEM NO.	PART NUMBER	DESCRIPTION	QTY.
1	2881278D	CHANNEL, BASE, SOLAR 65+W (4 PANEL)	1
2	2881279C	TUBING, RECTANGULAR, SOLAR 65W+ (2 PANEL)	4
3	2881284A	ASSEMBLY, WELD, SUPPORT, CHANNEL	1
4	2881286A	CHANNEL, BRACKET, WELD	2
5	2881333	HARDWARE KIT	1
HARDWARE KIT PARTS ARE LISTED BEOW			
101	7002080A-80	SCREW,HEX, SS, 3/8-16 X 5, FULL THREAD	3
102	7058A013	NUT, EL, EL STOP, HEX, LT SS, 3/8-16	3
103	7074A046	LKWSHR, SPLT, SS, 3/8	3
104	7000A311-30	SCREW, MACH, 1/4-20, HEX HD, SS	24
105	7072028	WASHER, FLT, 1/4, .625 OD, 0.065" THK, STEEL	24
106	7074015	WASHER,, SPLT, 1/4, .489 OD, 0.072" / 0.062" THK	24
107	70700950A	NUT, HEX, 1/4-20, 0.22" THK, 316 SS	24

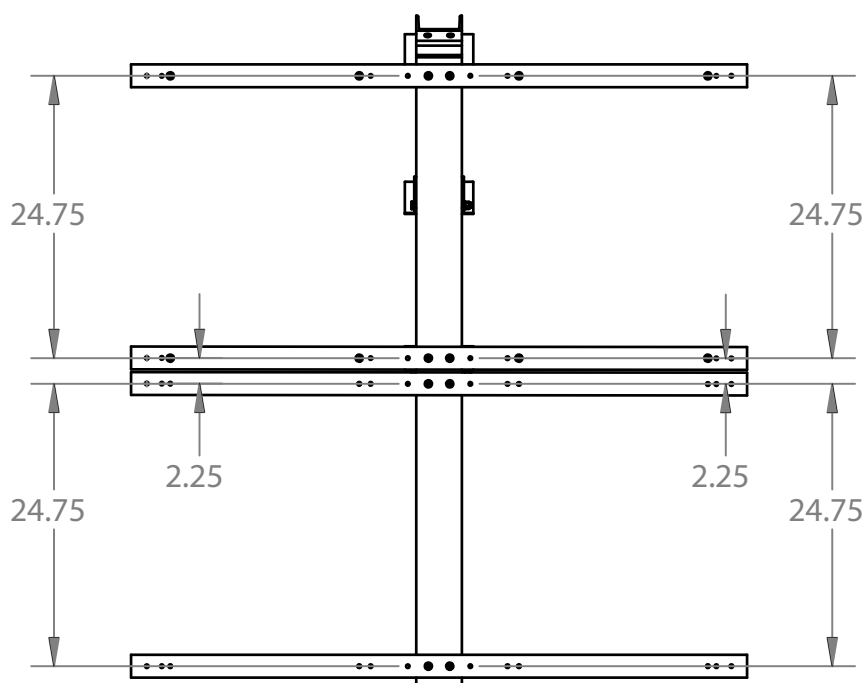

BRACKET ASSEMBLY

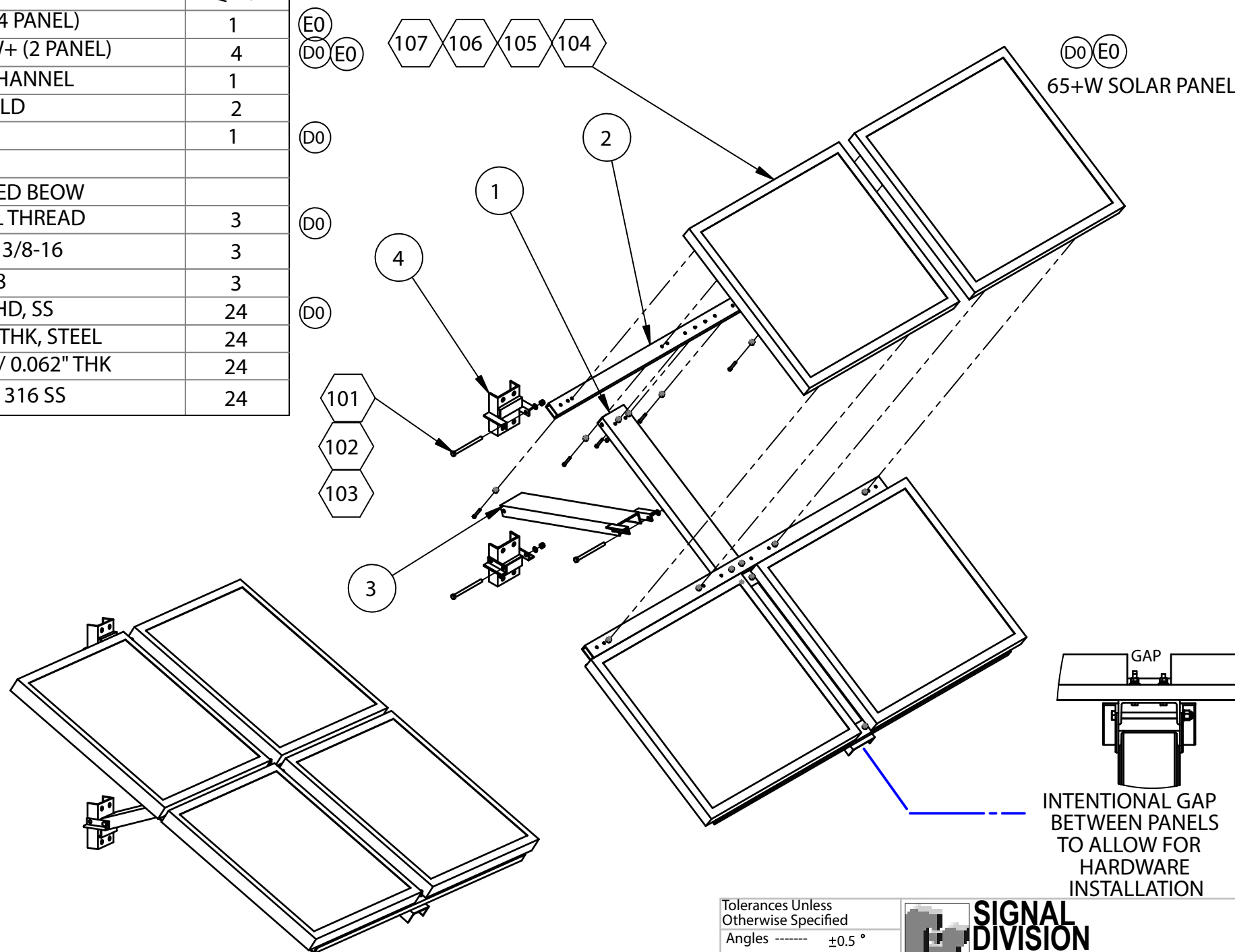

Tolerances Unless
Otherwise Specified
Angles ----- ±0.5 °
X.XX ----- ±0.015
X.XXX ----- ±0.005

SIGNAL DIVISION
Federal Signal Corporation
2645 FEDERAL SIGNAL DRIVE - UNIVERSITY PARK, IL 60466

E0	SEE ECR #20668	05/09/24	FJG	FINISH:	NONE	MATERIAL DESCRIBED AND INFORMATION CONVEYED IS PROPRIETARY TO FEDERAL SIGNAL CORPORATION, IS OR MAY BE THE SUBJECT OF PATENT APPLICATIONS, AND MAY NOT BE COPIED, DIVULGED TO OTHERS, OR USED FOR MANUFACTURING WITHOUT CONSENT.			
D1	SEE ECR#8984	2/7/18	MAF		REMOVE BURRS, SHARP CORNERS AND EDGES				
D0	SEE ECR# 5602	5/23/16	MAF	MATERIAL:	AS SPECIFIED	UNIT OF MEASURE	DRAWN BY: VT	CHKD. BY: SC	SCALE AT B SIZE: NONE
C	SEE ECR# 10-7179	12/6/10	VT			PC	DATE: 1/30/09	DATE: 2/2/09	
B1	SEE ECR #09-5802	1/8/10	MAF	NAME:	FINAL ASSEMBLY, SOLAR BRACKET 65W+ (4 PANEL)		DRAWING NUMBER: 2881287E		
B	SEE ECO# 09-4542	3/10/09	VT						
REV	CHANGE	DATE	BY						

Figure 15 Final Assembly Solar Bracket Side Mount 110 W (Two Panels)

ITEM NO.	PART NUMBER	DESCRIPTION	QTY.
1	2881286A	CHANNEL, BRACKET, WELD	2
2	861000472A	TUBING, RECTANGULAR, SOLAR 110W	2
3	861000473A	CHANNEL, BASE, SOLAR SIDE MT 110W	1
4	861000126A	ASSY., WELD, SUPPORT, CHANNEL SIDE MT 110W	1
5	2881333	HARDWARE KIT	1

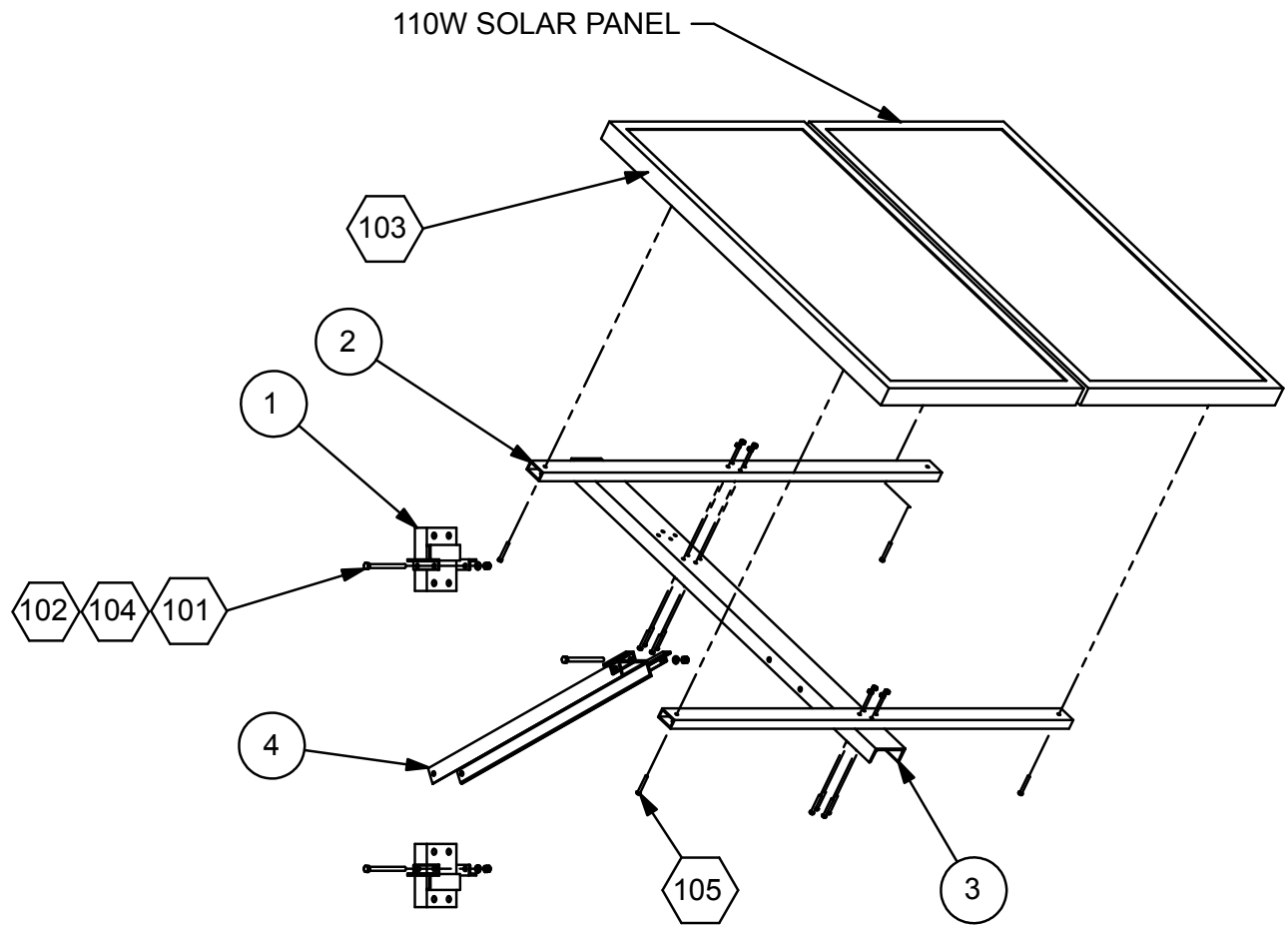
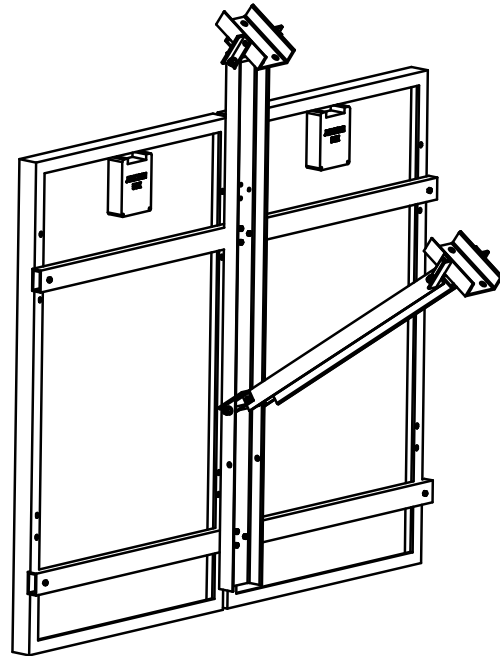
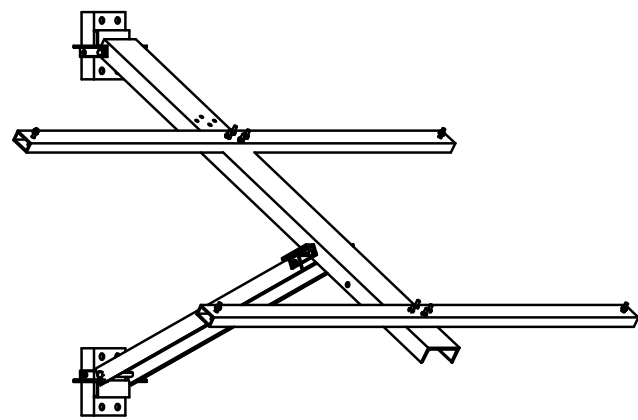

F			
ITEM NUMBER	PART NUMBER	DESCRIPTION	QTY
101	7002080A-80	SCREW, HEX, SS, 3/8-16 X 5, FULL THD	3
102	7058A013	NUT, EL STOP, 3/8-16, 0.468/0.138" THK, SS	3
103	7058050A	NUT, MACH SCREW, KEPS, 1/4-20	12
104	7074A046	LKWSHR, SPLIT, SS, 3/8	4
105	7000A311-30	SCR HEX HD SS 1/4-20 X 1-7/8	12

SHEET: 1 OF 1

UNITS: INCHES

FEDERAL SIGNAL 2645 FEDERAL SIGNAL DRIVE UNIVERSITY PARK, IL 60484	SAFETY & SECURITY GROUP	Tolerances Unless Otherwise Specified		NAME
		IN[mm]	ANGLES	FINISH
MATERIAL DESCRIBED AND INFORMATION CONVEYED IS PROPRIETARY TO FEDERAL SIGNAL CORPORATION, IS OR MAY BE THE SUBJECT OF PATENT APPLICATIONS, AND MAY NOT BE COPIED, DIVULGED TO OTHERS, OR USED FOR MANUFACTURING WITHOUT CONSENT.		±0.5° ±0.015[±0.4] ±0.005[±0.12]	NONE REMOVE BURRS, SHARP CORNERS AND EDGES	SCALE AT B SIZE: NONE THIRD ANGLE PROJECTION
MATERIAL			AS SPECIFIED	UNIT OF MEASURE
A1 SEE ECR #22057			02/21/25	FJG
A0 RELEASE TO PROD ECR #20091			01/16/24	FJG
REV.	CHANGE	DATE	BY	DATE: 01/16/24
DRAWN BY: FJG			CHKD. BY: DC	DRAWING NUMBER
DATE: 01/16/24			DATE: 01/16/24	861000475A

Figure 16 Final Assembly Solar Bracket Top-of-Pole Mount 110 W (Two Panels)

REV	ITEM NO.	PART NUMBER	DESCRIPTION	QTY.
	1	861000472A	TUBING, RECTANGULAR, SOLAR 110W	2
	2	861000471A	CHANNEL, BASE, SOLAR 110W	1
	3	2881295A	ASSY, WELD, CHANNEL SUPPORT, TOP-OF-POLE MOUNT	1
	4	2881294A	ASSEMBLY, WELD, BASE BRACKET	1
	5	2881335	BOLT, U, 1/2-13, , SS, FOR 4" PIPE	1
	6	2881298A	WELD ASSY, BRACKET, TOP-OF-POLE MOUNT	1
	7	8570073A	WELDMENT ASSY, PIPE SLEEVE, SOLAR, PVS220W-24-H-TM	1
A1	8	78000408	CARTON, 51-53" LIGHTBAR	1
A1	9	8283A661-PERF	PAD,POLYETH,BUBBLE,PERFORATED 12"	3
A1	10	71401603A	LABEL,CARTON.BLANK,2x4	1

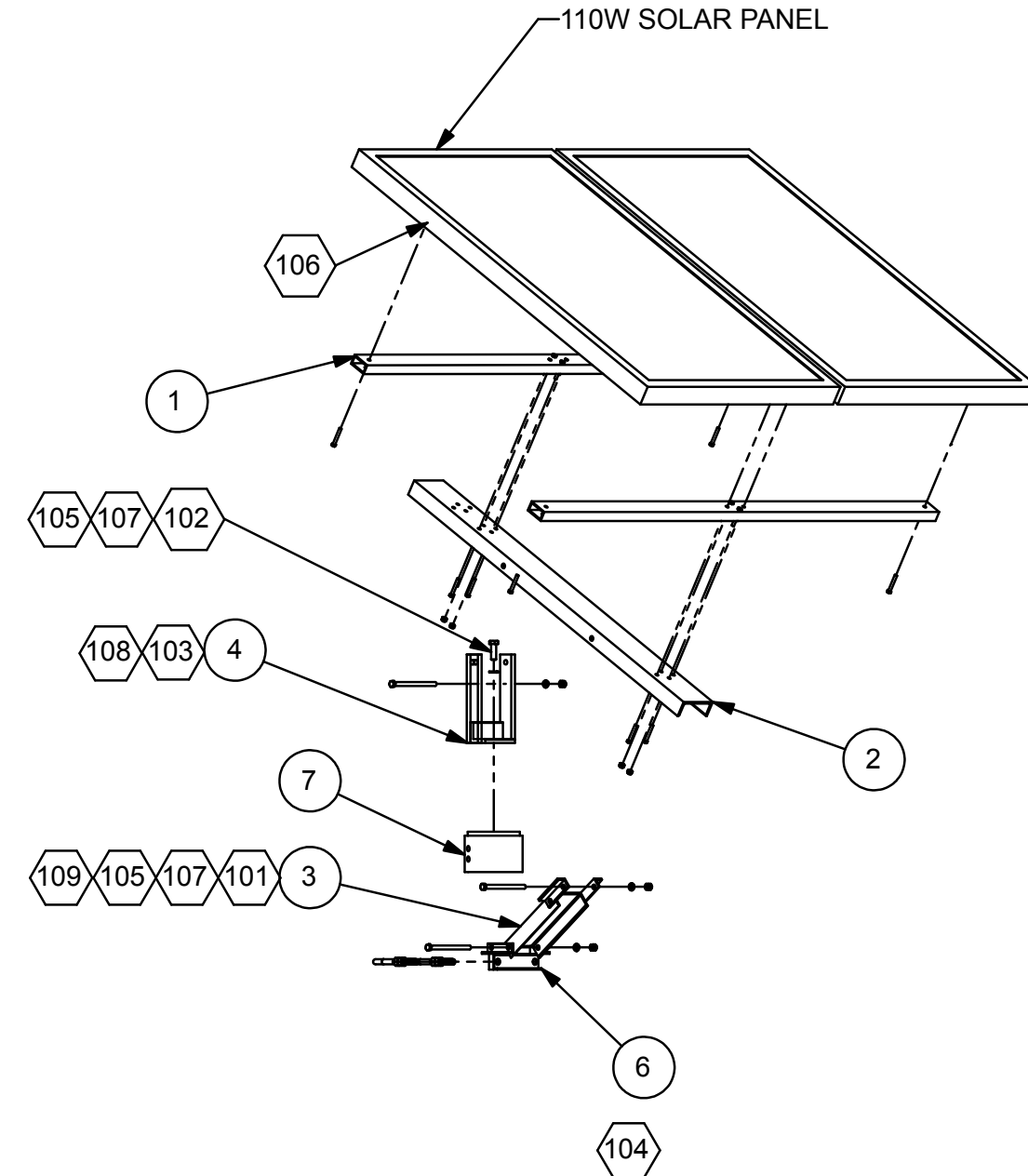
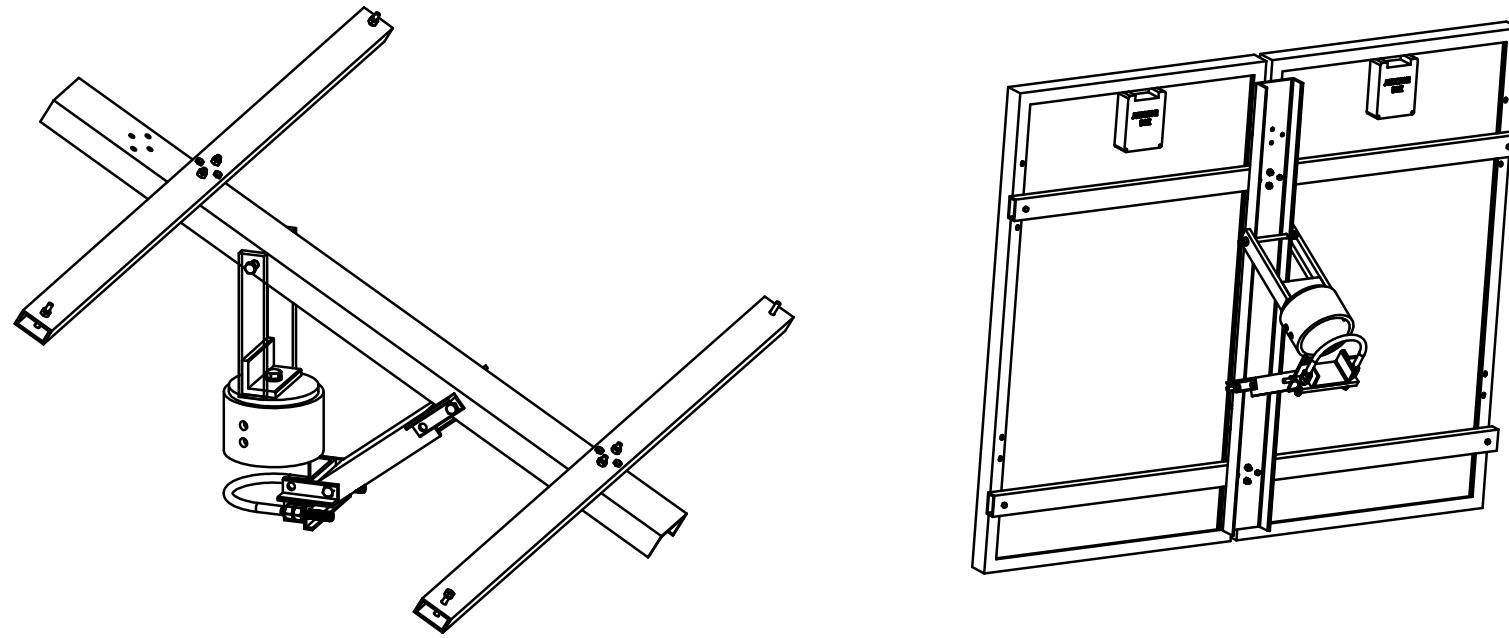

HARDWARE KIT PARTS LISTED BELOW			
ITEM NUMBER	PART NUMBER	DESCRIPTION	QTY
100	7000A311-30	SCR, HEX HD, SS, 1/4-20 X 1-7/8	12
101	7002080A-88	SCREW, HEX, SS, 3/8-16 X 5-1/2	2
102	7002080-96	SCREW, HEX, SS, 3/8-16 X 6	1
103	7002A014-24	SCREW, HEX HD, SS, 1/2-13 X 1-1/2	1
104	7003018A	BOLT, U, 1/2-13, SS, FOR A 4" PIPE	1
105	7058A013	NUT, EL STOP, 3/8-16, 0.468/0.436" THK, SS	3
106	7058A010	NUT, EL STOP, 1/4-20, SS	12
107	7074A046	LKWSHR, SPLT, SS, 3/8	3
108	7074A059	WASHER, SPLT, 1/2, 0.873 OD, 0.135/0.125"	1
109	7000A338-104	SCREW, HEX HD, 1/2-13, SS	2

SHEET: 1 OF 1

UNITS: INCHES

FEDERAL SIGNAL 2645 FEDERAL SIGNAL DRIVE UNIVERSITY PARK, IL 60484	SAFETY & SECURITY GROUP	Tolerances Unless Otherwise Specified		NAME FINAL ASSEMBLY, SOLAR BRACKET TOP-OF-POLE MOUNT, 110W (2 PANEL)			
		IN[mm]	±0.5 *				
MATERIAL DESCRIBED AND INFORMATION CONVEYED IS PROPRIETARY TO FEDERAL SIGNAL CORPORATION, IS OR MAY BE THE SUBJECT OF PATENT APPLICATIONS, AND MAY NOT BE COPIED, DIVULGED TO OTHERS, OR USED FOR MANUFACTURING WITHOUT CONSENT.		Angles	±0.015[±0.4]	FINISH	NONE	SCALE AT B SIZE:	NONE
		x.xx[x.x]	±0.005[±0.12]	REMOVE BURRS, SHARP CORNERS AND EDGES		THIRD ANGLE PROJECTION	
		x.xxx[x.xx]	---	MATERIAL	AS SPECIFIED	UNIT OF MEASURE	PC
A2	SEE ECR #22057	02/21/25	FJG	DRAWN BY: FJG	CHKD. BY: DC	DRAWING NUMBER	
A1	SEE ECR #21751	01/14/25	APK	DATE: 01/17/24	DATE: 01/17/24	861000474A	
A0	RELEASE TO PROD ECR #20091	01/17/24	FJG				
REV.	CHANGE	DATE	BY				

Figure 17 DCB and DCFCB Solar Wiring

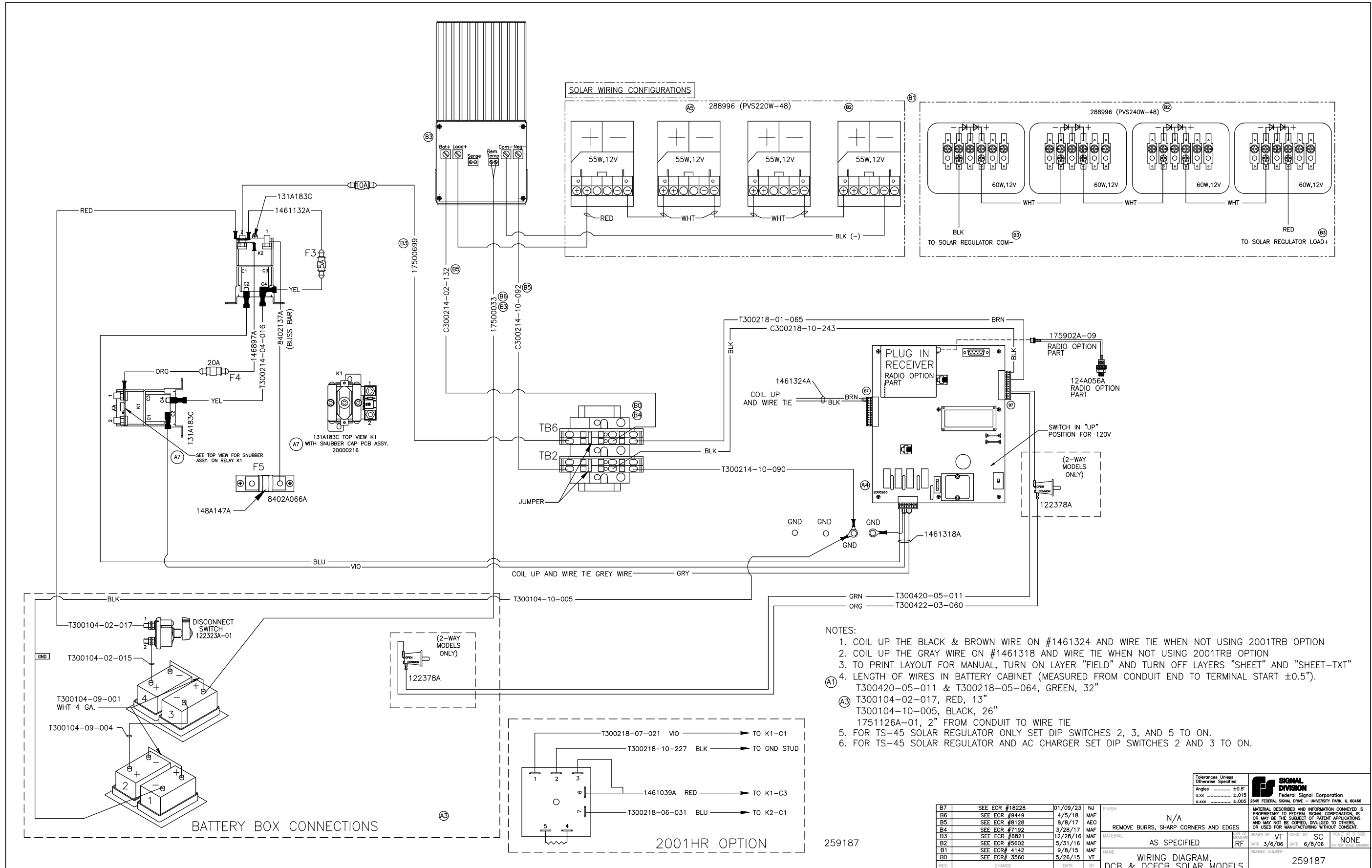
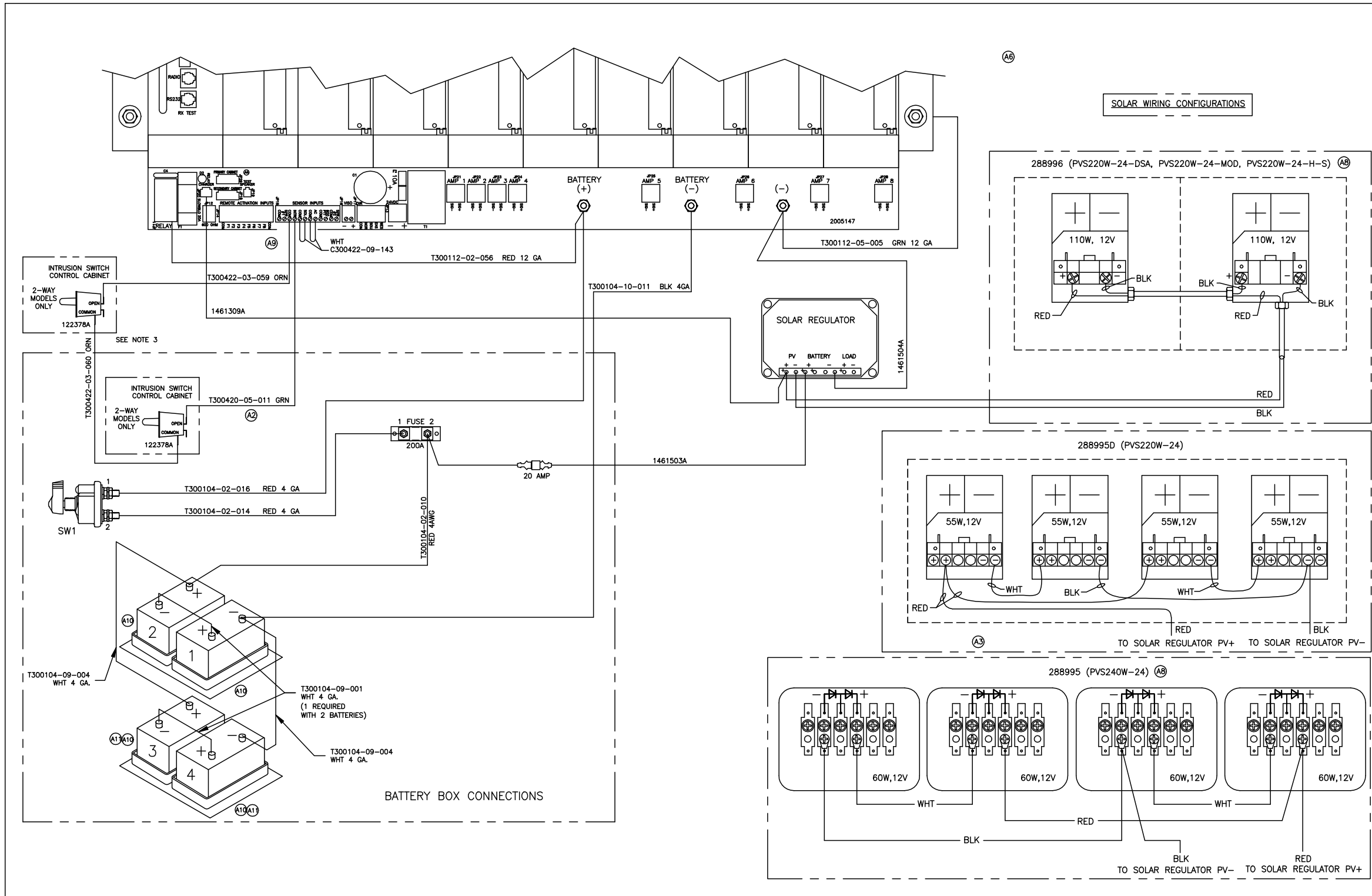

Figure 19 One-Way Solar UltraVoice Wiring Diagram



- NOTES:
- BATTERY CONNECTIONS ARE MADE DURING SIREN INSTALLATION.
 - WHEN USING ONLY TWO BATTERIES, DO NOT USE (3) WHITE 4 AWG WIRES (T300104-09-004).
 - ORANGE INTRUSION SWITCH WIRES INCLUDED FOR POSSIBLE FUTURE USE.
 - LENGTH OF WIRES IN BATTERY CABINET (MEASURED FROM CONDUIT END TO TERMINAL START $\pm 0.5"$).
 - T300422-03-060 & T300422-03-061, ORANGE, 36"
 - T300104-02-016, RED, 13"
 - T300104-10-011, BLACK, 10.5"
 - 1461503A, 6.5"

REV.	CHANGE	DATE	BY
A11	SEE ECR #13104	2/20/20	MAF
A10	SEE ECR #12829	2/4/20	NJ
A9	SEE ECR #10489	10/5/18	MAF
A8	SEE ECR #5602	5/31/16	MAF
A7	SEE ECR #5838	9/21/16	MAF
A6	SEE ECR# 4142	9/8/15	MAF
A5	SEE ECR# 2268	8/22/14	VT
A4	SEE ECR #443	2/13/13	BWH

Tolerances Unless Otherwise Specified		SIGNAL DIVISION Federal Signal Corporation 2645 FEDERAL SIGNAL DRIVE - UNIVERSITY PARK, IL 60466	
Angles	----- $\pm 0.5^\circ$	MATERIAL DESCRIBED AND INFORMATION CONVEYED IS PROPRIETARY TO FEDERAL SIGNAL CORPORATION, IS OR MAY BE THE SUBJECT OF PATENT APPLICATIONS, AND MAY NOT BE COPIED, DIVULGED TO OTHERS, OR USED FOR MANUFACTURING WITHOUT CONSENT.	
x.xx	----- ± 0.015		
x.xxx	----- ± 0.005		
FINISH	N/A		DRAWN BY VT DATE 3/10/06
MATERIAL	AS SPECIFIED		CHKD. BY SC DATE 6/8/06
NAME	WIRING DIAGRAM		SCALE AT C SIZE: NONE DO NOT SCALE DRAWING
1-WAY, SOLAR, ULTRAVOICE			DRAWING NUMBER 259185A

Figure 20 Two-Way Solar UltraVoice Wiring Diagram

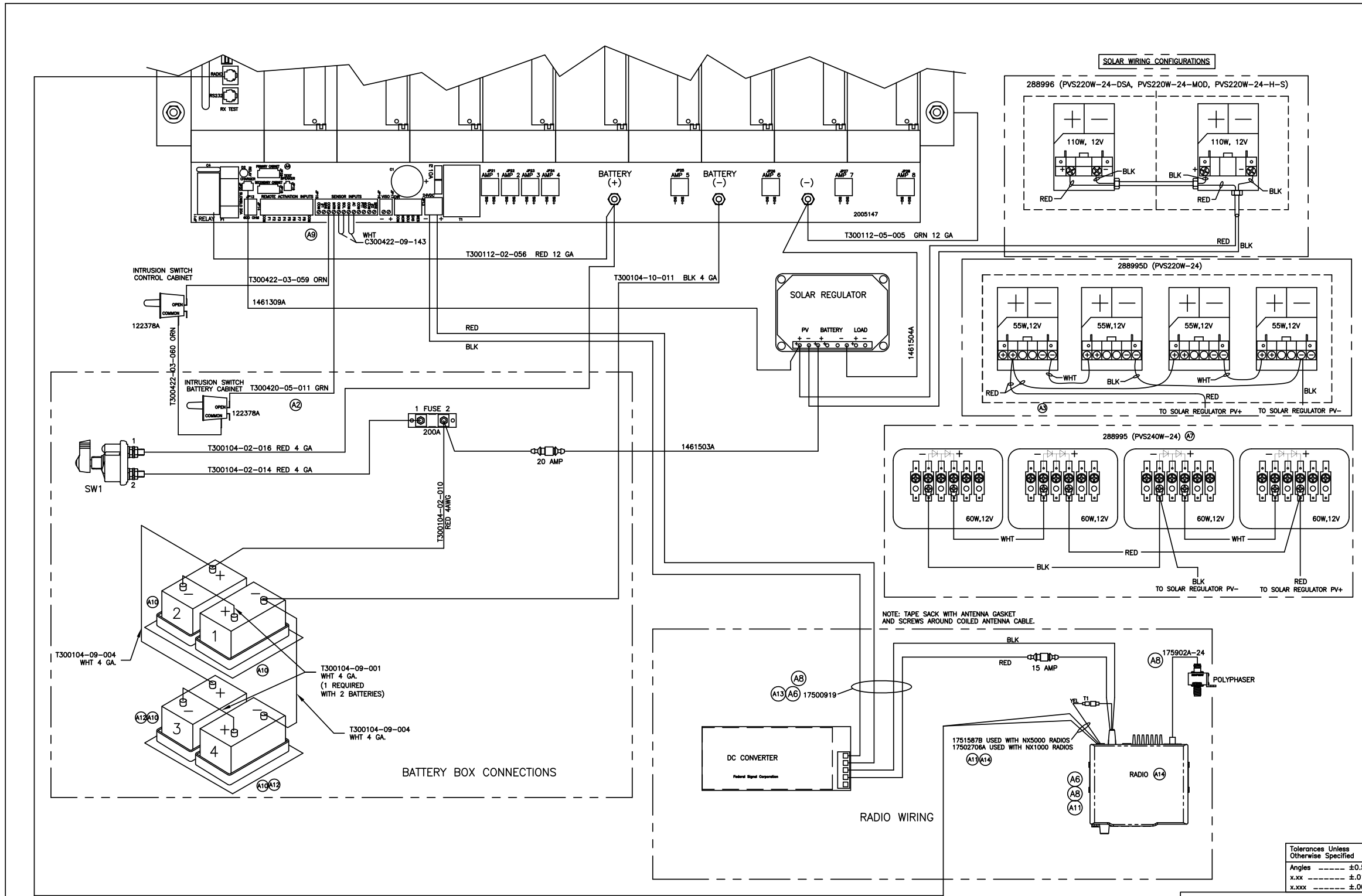

- NOTES:
- BATTERY CONNECTIONS ARE MADE DURING SIREN INSTALLATION.
 - WHEN USING ONLY TWO BATTERIES, DO NOT USE (3) WHITE 4 AWG WIRES (T300104-09-004).
 - LENGTH OF WIRES IN BATTERY CABINET (MEASURED FROM CONDUIT END TO TERMINAL START $\pm 0.5"$)
 T300422-03-060 & T300422-03-061, ORANGE, 36"
 T300104-02-016, RED, 13"
 T300104-10-011, BLACK, 10.5"
 1461503A, 6.5"

REV	CHANGE	DATE	BY
A14	SEE ECR #17729	10/10/22	NJ
A13	SEE ECR #13145	3/2/20	MAF
A12	SEE ECR #13104	2/20/20	MAF
A11	SEE ECR #12829	2/3/20	MAF
A10	NOT RELEASED	**	NJ
A9	SEE ECR #10458	10/5/18	NJ
A8	SEE ECR #9210	2/23/18	MAF
A7	SEE ECR #5602	5/31/16	MAF

SIGNAL DIVISION
Federal Signal Corporation
2645 FEDERAL SIGNAL DRIVE - UNIVERSITY PARK, IL 60466

MATERIAL DESCRIBED AND INFORMATION CONVEYED IS PROPRIETARY TO FEDERAL SIGNAL CORPORATION, IS OR MAY BE THE SUBJECT OF PATENT APPLICATIONS, AND MAY NOT BE COPIED, DIVULGED TO OTHERS, OR USED FOR MANUFACTURING WITHOUT CONSENT.

FINISH	N/A	REMOVE BURRS, SHARP CORNERS AND EDGES
MATERIAL	AS SPECIFIED	
DATE	3/10/06	DATE
DATE	6/8/06	DATE
NAME	WIRING DIAGRAM	
NAME	2-WAY, SOLAR, ULTRAVOICE	
DRAWING NUMBER	259186A	

Figure 21 Two-Way Primary AC with Solar UltraVoice Wiring Diagram

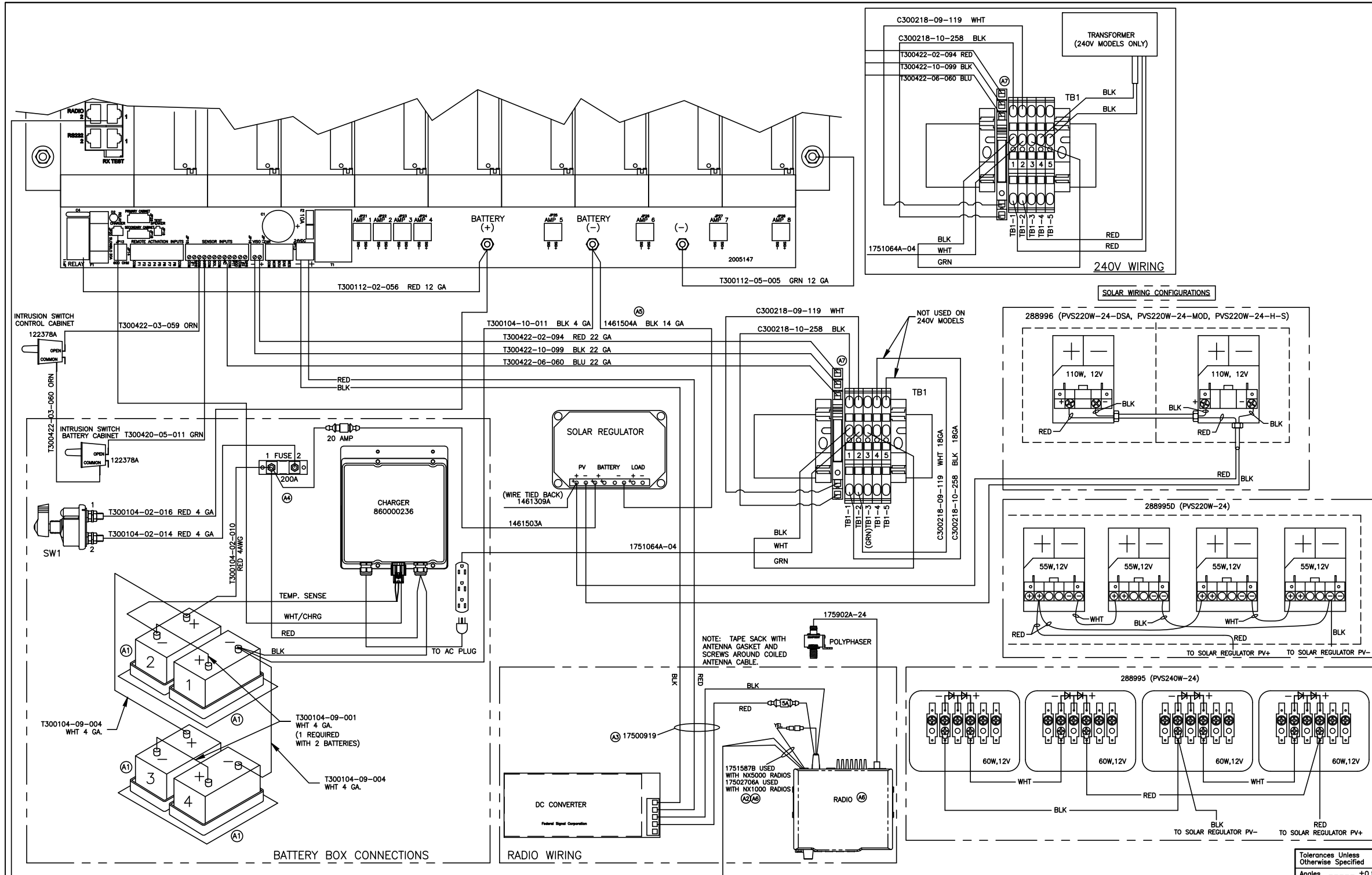

NOTES:

- BATTERY CONNECTIONS ARE MADE DURING SIREN INSTALLATION.
- WHEN USING ONLY TWO BATTERIES, DO NOT USE (3) WHITE 4 AWG WIRES (T300104-09-004).
- LENGTH OF WIRES IN BATTERY CABINET (MEASURED FROM CONDUIT END TO TERMINAL START ±0.5")
 - T300422-03-060 & T300422-03-061, ORANGE, 36"
 - T300104-02-016, RED, 13"
 - T300104-10-011, BLACK, 10.5"
 - 1461503A, 6.5"

A7	SEE ECR #23793	3/3/26	APK
A6	SEE ECR #17729	10/10/22	FINISH
A5	SEE ECR #14241	10/7/20	N/A
A4	SEE ECR #13695	6/16/20	REMOVE BURRS, SHARP CORNERS AND EDGES
A3	SEE ECR #13145	3/2/20	MATERIAL
A2	SEE ECR #12829	2/8/20	AS SPECIFIED
A1	NOT RELEASED	8/MAR/19	RF
A0	SEE ECR #10420	9/25/18	NAME
REV.	CHANGE	DATE	BY

UNIT OF MEASURE	RF
DRAWN BY	NJ
DATE	09/13/18
CHKD. BY	ARP
DATE	09/13/18
SCALE AT C SIZE	NONE
DO NOT SCALE DRAWING	
DRAWING NUMBER	850000814A

SIGNAL DIVISION
Federal Signal Corporation
2645 FEDERAL SIGNAL DRIVE - UNIVERSITY PARK, IL 60466

MATERIAL DESCRIBED AND INFORMATION CONVEYED IS PROPRIETARY TO FEDERAL SIGNAL CORPORATION, IS OR MAY BE THE SUBJECT OF PATENT APPLICATIONS, AND MAY NOT BE COPIED, DIVULGED TO OTHERS, OR USED FOR MANUFACTURING WITHOUT CONSENT.

Tolerances Unless Otherwise Specified
Angles ±0.5°
x.xx ±0.15
x.xxx ±0.05

Figure 22 Two-Way Primary Solar with AC UltraVoice Wiring Diagram

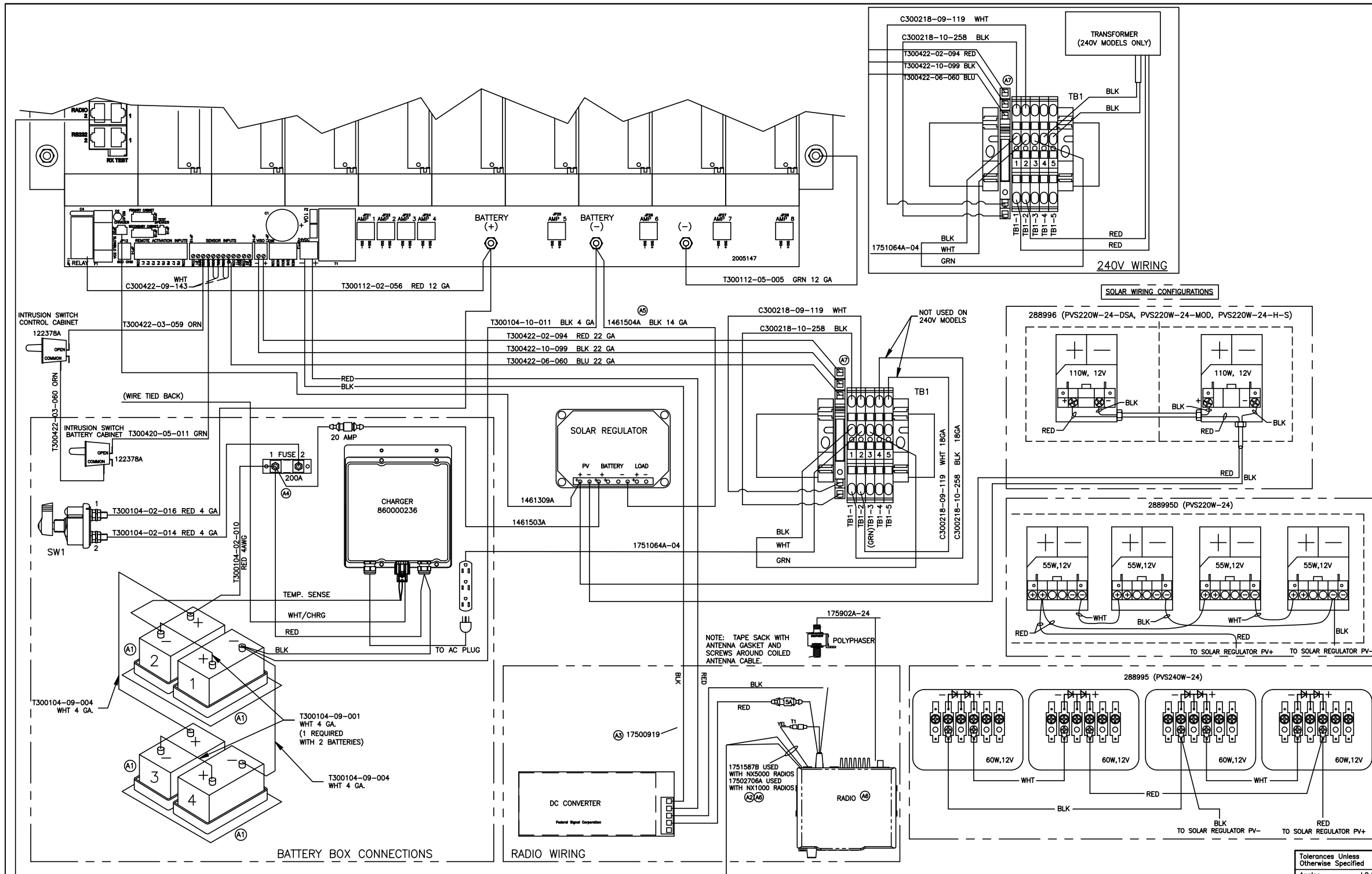

- NOTES:
- BATTERY CONNECTIONS ARE MADE DURING SIREN INSTALLATION.
 - WHEN USING ONLY TWO BATTERIES, DO NOT USE (3) WHITE 4 AWG WIRES (T300104-09-004).
 - LENGTH OF WIRES IN BATTERY CABINET (MEASURED FROM CONDUIT END TO TERMINAL START $\pm 0.5"$).
 T300422-03-060 & T300422-03-061, ORANGE, 36"
 T300104-02-016, RED, 13"
 T300104-10-011, BLACK, 10.5"
 1461503A, 6.5"

REV.	CHANGE	DATE	BY
A7	SEE ECR #23793	3/3/26	APK
A6	SEE ECR #17729	10/10/22	NJ
A5	SEE ECR #14241	10/7/20	NJ
A4	SEE ECR #13695	6/16/20	MAF
A3	SEE ECR #13145	3/2/20	MAF
A2	SEE ECR #12829	2/8/20	MAF
A1	NOT RELEASED	8/MAR/19	PJB
A0	REF. ECR #10420	9/25/18	NJ

SIGNAL DIVISION
Federal Signal Corporation
2645 FEDERAL SIGNAL DRIVE - UNIVERSITY PARK, IL 60466

MATERIAL DESCRIBED AND INFORMATION CONVEYED IS PROPRIETARY TO FEDERAL SIGNAL CORPORATION, IS OR MAY BE THE SUBJECT OF PATENT APPLICATIONS, AND MAY NOT BE COPIED, DIVULGED TO OTHERS, OR USED FOR MANUFACTURING WITHOUT CONSENT.

FINISH: N/A
REMOVE BURRS, SHARP CORNERS AND EDGES

MATERIAL: AS SPECIFIED

NAME: WIRING DIAGRAM, 2-WAY, PRIMARY SOLAR W/AC, ULTRAVOICE

DRAWN BY: NJ
DATE: 09/13/18

CHKD. BY: ARP
DATE: 09/13/18

SCALE AT C SIZE: NONE
DO NOT SCALE DRAWING

DRAWING NUMBER: 850000815A

Tolerances Unless Otherwise Specified
Angles $\pm 0.5^\circ$
x.xxx ± 0.15
x.xxx ± 0.05

Figure 23 Hawaii UltraVoice Wiring Diagram

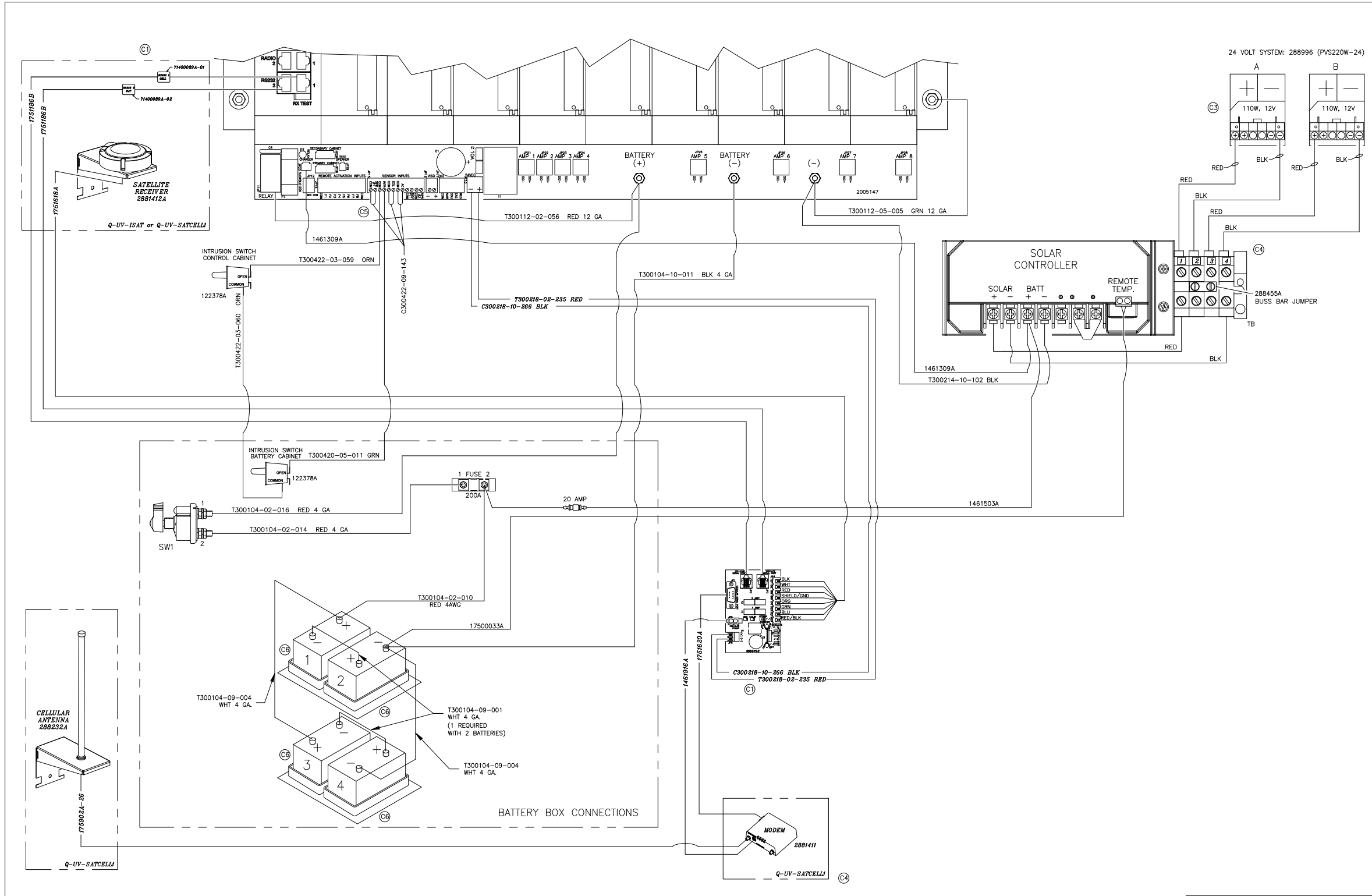

- NOTES:
1. OPTIONS SHOWN IN ITALICIZED TEXT FOR REFERENCE.
 2. BATTERY, SATELLITE RECEIVER & ANTENNA CONNECTIONS MADE DURING SIREN INSTALLATION.
 3. WHEN USING ONLY TWO BATTERIES, DO NOT USE (3) WHITE 4 AWG WIRES (T300104-09-004).
 4. LENGTH OF WIRES IN BATTERY CABINET (MEASURED FROM CONDUIT END TO TERMINAL START ±0.5")
 T300420-05-011, GREEN, 36"
 T300104-02-016, RED, 13"
 T300104-10-011, BLACK, 10.5"

REV.	CHANGE	DATE	BY

FINISH	N/A
MATERIAL	AS SPECIFIED
NAME	WIRING DIAGRAM, HAWAII SOLAR IN UV

SIGNAL DIVISION
 Federal Signal Corporation
 2645 FEDERAL SIGNAL DRIVE - UNIVERSITY PARK, IL 60466

MATERIAL DESCRIBED AND INFORMATION CONVEYED IS PROPRIETARY TO FEDERAL SIGNAL CORPORATION, IS OR MAY BE THE SUBJECT OF PATENT APPLICATIONS, AND MAY NOT BE COPIED, DIVULGED TO OTHERS, OR USED FOR MANUFACTURING WITHOUT CONSENT.

DRAWN BY	VT	CHKD. BY	RW	SCALE	AT C SIZE: NONE
DATE	5/25/12	DATE	12/14/12	UNIT OF MEASURE	RF
DRAWING NUMBER			259298C		

Figure 24 Solar Assembly for the UltraVoice

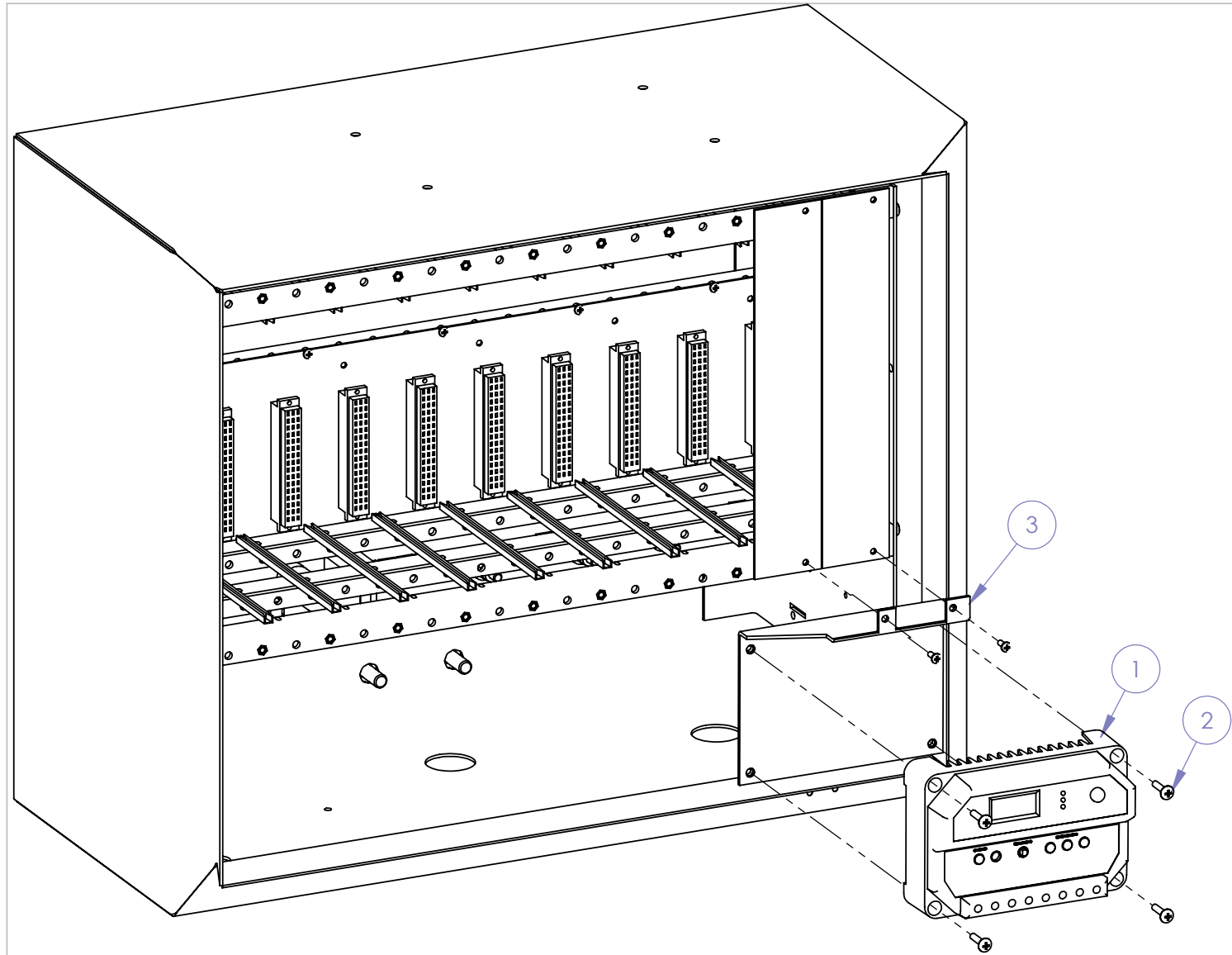

ITEM NO.	QTY.	PART NUMBER	DESCRIPTION
1	1	288964A-24	SOLAR REGULATOR, MORNING STAR, PROSTAR
2	4	7000A070-12	SCREW, MACH, 10-32, RND HD, PHIL, SS, 3/4
3	1	8600148A-01	BRKT ASSY, SOLAR, PROSTAR, UV
*	1	1461503A	WIRE LEAD, BATTERY (+), SOLAR, UV
*	1	1461504A	WIRE LEAD, SOLAR GND TO MOTHERBOARD
(B4) *	3	C300422-09-143	CUT WIRE, 1/4NT:1/4NT, 1.5"
(B4) NT SHWN	1	255379	MANUAL
(B3) **	1	288995	SOLAR KIT, SUNWIZE PVS220W-24/PVS240W-24
(B4) **	1	2881287	SOLAR BRACKET
(B4) **	1	2881336	KIT, CABLE AND CLAMP, SOLAR
(B4) **	2	7000A427-10	SCREWS, 6-32, SS
(B4) REF	0	259185	WIRING DIA, UV 1-WAY, SOLAR
(B4) REF	0	259186	WIRING DIA, UV 2-WAY, SOLAR
REF	0	8600109	FINAL ASSY, UV 1-WAY
REF	0	8600111	FINAL ASSY, UV 2-WAY

* SHOWN ON WIRING DIAGRAM
 ** NOT SHOWN, SHIPPED DIRECT TO CUSTOMER

DELETIONS FOR SOLAR OPTION (1-WAY & 2-WAY)		
QTY.	PART NUMBER	DESCRIPTION
1	120816	CHARGER, 24V, 10A
1	1612393B	LABEL, DIN RAIL, UV
2	229218A	BRKT, T-BLOCK, END
4#	229282A	TERM. BLOCK, 1-POLE, 35MM DIN
1##	229283A	CAP, END, TERM BLOCK, 1 POLE
1	229288A	GROUND TERM BLOCK, 3 POS
1	288810A-04	DIN RAIL, ALUM, UNCOATED, 4.00"
1###	288454B	INPUT MODULE, 120V
2	7011A152-06	#8 SHT METAL SCREW, SS
(B2) 6	7058050A	NUT, MACH SCREW, KEPS 1/4-20
1	8600112A-01	BRKT ASSY, PWR SUPPLY

DELETIONS (CONT.)		
QTY.	PART NUMBER	DESCRIPTION
1	1751064A-04	CABLE, AC TERMINATED
2###	C300218-09-119	WIRE, CUT, WHT, 5"
2###	C300218-10-258	WIRE, CUT, BLK, 5"
1###	T300422-02-094	T-WIRE, RED, 28"
1###	T300422-06-060	T-WIRE, BLUE, 28"
1###	T300422-10-099	T-WIRE, BLACK, 28"
1	8549A193A	LIGHTNING PROTECTOR
1	1461243A	WIRE LEAD, FUSED, POWER SUPPLY
(B2) 1	81461875B	LABEL, NAMEPLATE, UL
1	1612875A-05	LABEL, ELECTRICAL RATINGS

ONLY QTY 2 ON 1-WAY
 ## ONLY 1-WAY MODELS
 ### ONLY 2-WAY MODELS

Tolerances Unless
 Otherwise Specified
 Angles ----- ±0.5°
 X.XX ----- ±0.015
 X.XXX ----- ±0.005

SIGNAL DIVISION
 Federal Signal Corporation
 2645 FEDERAL SIGNAL DRIVE - UNIVERSITY PARK, IL 60466

			FINISH:	N/A		
				REMOVE BURRS, SHARP CORNERS AND EDGES		
			MATERIAL:	N/A		
				UNIT OF MEASURE	RF	
B4	SEE ECO #5602	5/31/16	MAF	DATE:	7/8/05	SCALE AT B SIZE: NONE
B3	SEE ECO #08-2746	2/26/08	VT	CHKD. BY:	MJF	DATE: 9/21/05
B2	SEE ECO #05-4180	11/22/05	MAF	DRAWING NUMBER:		
B1	REL TO PROD ECO #05-4142	9/21/05	MAF	8600124B		
REV	CHANGE	DATE	BY			

Figure 25 Solar Assembly for the DC Series Siren Control System

ITEM #	QTY.	PART NO.	DESCRIPTION
1	1	2881240A	TS DIGITAL METER
2	1	288812A	SOLAR REGULATOR, TS-45
3	4	7000A070-12	SCREW, MACH. 10-32, RND HD, PHIL, SS, 3/4
4	1	7058050A	NUT, MACH SCR, KEPS, 1/4-20
*	1	C300214-02-132	CUT WIRE, RED, 35"
*	1	C300214-10-092	CUT WIRE, BLACK, 35"
**	1	288995	SOLAR KIT, SUNWIZE
REF	0	259187	WIRING DIA, DCB/DCFCB, SOLAR
REF	0	259188	WIRING DIA, DCFCTB, SOLAR
REF	0	8402147	FINAL ASSY, DCFCTB
REF	0	8402148	FINAL ASSY, DCFCB
NOT SHOWN	1	17500033A	REMOTE SENSOR
NOT SHOWN	1	255379	MANUAL
NOT SHOWN	1	2881287	SOLAR BRKT ASSY, 55W/60W (4 PANEL)
NOT SHOWN	1	2881336A	KIT, CABLE AND CLAMP, SOLAR
5	1	840200308A	BRKT ASSY, SOLAR REG MOUNT

* SHOWN ON WIRING DIAGRAM

** NOT SHOWN, SHIPPED DIRECT TO CUSTOMER

C2

C1

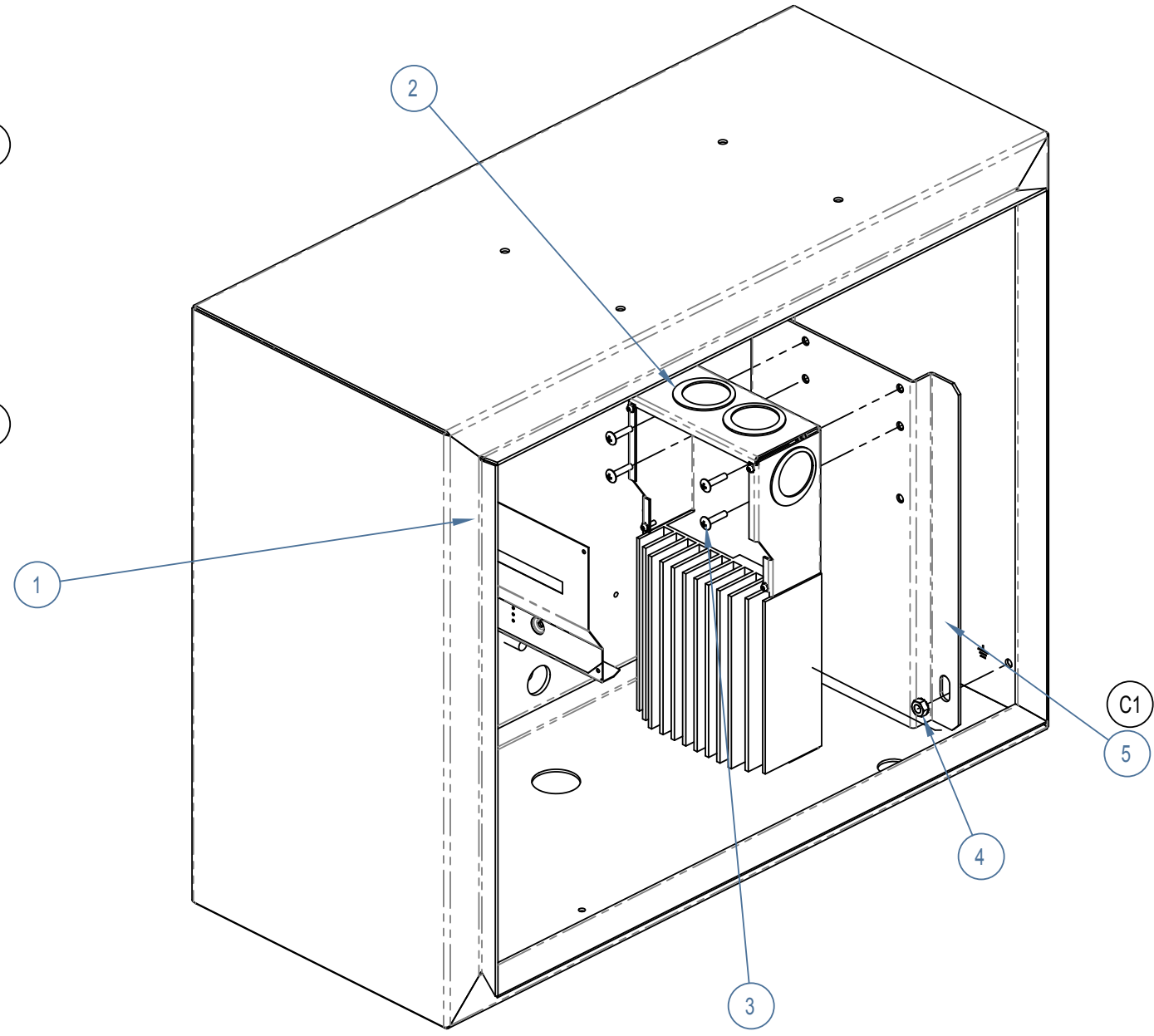

DELETIONS FOR SOLAR OPTION (1-WAY & 2-WAY)		
QTY	PART NO.	DESCRIPTION
2	143139A	FUSE LEVER
2	143140A	FUSE COVER
1	1461361A	WIRE LEAD, 110V PWR
2	148154A	FUSE, 10A
1	1461389A	WIRE ASSY, BAT CHRGR
1	1612400A	LABEL, FC CONTROL
1	1612875A-03	LABEL, UL ELECT. RATING
1	1751064A-04	CABLE, AC FOR BATT CAB.
2	229218A	BRKT, BLOCK END
4	229282A	TERM BLOCK
1	229288A	GROUND TERM BLOCK
2	288782A	JUMPER
1	288810A-04	DIN RAIL
2	7011A069-08	SCREW
4	7058050A	KEPS NUT, 1/4-20
1	81461875B	LABEL, NAMEPLATE
1	840200205	BATTERY CHARGER
1	8549A193A	LIGHTNING PROTECT.
1	C300218-09-119	CUT WIRE
1	C300218-10-258	CUT WIRE

SHEET: 1 OF 1
UNITS: INCHES

FEDERAL SIGNAL 2845 FEDERAL SIGNAL DRIVE UNIVERSITY PARK, IL 60484		SAFETY & SECURITY GROUP	Tolerances Unless Otherwise Specified (N/mm) Angles x.xx(x.xx) x.xxx(x.xxx)	a 0.5 A a 0.015[a 0.4] a 0.005[a 0.12]	NAME SOLAR ASSY, DC, 48V	
MATERIAL DESCRIBED AND INFORMATION CONVEYED IS PROPRIETARY TO FEDERAL SIGNAL CORPORATION, IS OR MAY BE THE SUBJECT OF PATENT APPLICATIONS, AND MAY NOT BE COPIED, DIVULGED TO OTHERS, OR USED FOR MANUFACTURING WITHOUT CONSENT.				FINISH N/A		
C2 REL FOR ECR #8128 8/8/2017 AEO C1 REL FOR ECR #7436 5/17/2017 AEO C0 SEE ECR #6821 12/28/16 MAF B2 SEE ECO #07-4186 11/23/07 VT B1 SEE ECO #05-4180 11/22/05 MAF B REL TO PROD. ECO #05-4143 9/21/05 MAF				SCALE AT B SIZE: NONE		
REV. CHANGE DATE BY				REMOVE BURRS, SHARP CORNERS AND EDGES MATERIAL N/A UNIT OF MEASURE EA		
DRAWN BY: MAF DATE: 7/8/05		CHKD. BY: MJF DATE: 9/21/05		DRAWING NUMBER 8402166C		