

25500139C REV. C2 1117

Safety Message to Installers and Operators of Warning Lights

▲ WARNING

People's lives depend on your proper installation and servicing of Federal Signal products. It is important to read and follow all instructions shipped with this product and the original product. In addition, listed below are some other important safety instructions and precautions you should follow:

- To properly install the lighting system, you must have a good understanding of automotive systems, along with proficiency in the installation and use of safety warning equipment.
- Do not install equipment or route wiring in the deployment path of an airbag.
- If a vehicle seat is temporarily removed, verify with the vehicle manufacturer if the seat needs to be recalibrated for proper airbag deployment.
- You should frequently inspect the light system to ensure that it is operating properly and that it is securely attached to the vehicle.
- When drilling into a vehicle structure, be sure that both sides of the surface are clear of anything that could be damaged.
- When drilling into a vehicle structure, be sure that both sides of the surface are clear of anything that could be damaged. All drilled holes should be deburred and all sharp edges should be smoothed. All wires going through drilled holes should be protected by a grommet or convolute/split-loom tubing. Additionally, all exterior drilled holes must be sealed with Motorcraft seam sealer T-A-2-B or equivalent to prevent the potential exposure to carbon monoxide or other potentially harmful fumes. Failure to observe this warning could cause serious injury or death.
- Do not stare directly into the lights at a close range or permanent damage to your eyesight may occur.

Failure to follow all safety precautions and instructions may result in property damage, serious injury, or death.

Unpacking the Kit

After unpacking the product, inspect it for damage that may have occurred in transit. If it has been damaged or is missing a part, do not attempt to install or operate it. File a claim immediately with the carrier, stating the extent of the damage. Carefully check all envelopes, shipping labels and tags before removing or destroying them. Ensure that all parts in Table 1 have been included. If you are missing any parts, contact Customer Support at 1-800-264-3578, 7 A.M. to 5 P.M., Monday through Friday (CT).

Table 1 Kit contents (continued on next page)

Qty.	Description	Part Number
1	Gasket, 1.68 in x 3.67 in x 0.03 in	2881407
6	Screw, Hex, Washer Hd, SS, 1/4 in	7011183-12
6	Screw, Type TT, 8-32, Pan, 6-Lobe	70000143-06
1	Bracket, DS, MPS6/MPS6U, 3 Hd, Spoiler	861300851-DS
1	Bracket, PS, MPS6/MPS6U, 3 Hd, Spoiler	861300851-PS
2	Cover, MP6-FPIURS2, Spoiler	861300963
12	Screw, 6-32, Machine, Phillips Pan-Head, SS	7000491-08

Table 1 Kit contents (continued from previous page)

Qty.	Description	Part Number
12	Nut, Keps, 6-32 SS	7058A46
6	Lockwasher, SS, 1/4 in	7074A016
1	Grommet	228116
1	Kit, Ford Liftgate Spoiler	77700892

Precautions for Mounting the Brackets to the Spoiler

⚠ CAUTION

- When mounting brackets to the spoiler, use the provided dimensions in the installation instructions. When mounting the spoiler/bracket assembly, ensure that the spoiler sits flush against the vehicle liftgate.
- Ensure that the rear warning light harness does not double up or lay upon itself, preventing the rear spoiler from seating flush against the rear window of the liftgate. The rear warning light wiring harness must not prevent the rear spoiler/bracket assembly from sitting flush against the vehicle liftgate.
- After removal of the vehicle spoiler and prior to re-installation of the spoiler/bracket assembly, replace all spoiler seals with **FORD Liftgate Spoiler Kit Part Number: HB5Z-78442K03-A**.
- Reference FORD Customer Satisfaction Programming 17B25 and SVE Bulletin P-027.
- All warning light wiring must be convolute/split loom or equivalent. Wiring entering or exiting the spoiler and vehicle must be grommeted and sealed with T-A-2-B Seam Sealer to prevent the potential exposure to carbon monoxide or other potentially harmful fumes.
- All warning light wiring must be tie wrapped and/or routed to prevent interference with other rear vehicle wiring or sealing.

⚠ WARNING

AIRBAG DEPLOYMENT: Do not install equipment or route wiring in the deployment path of an airbag. Failure to observe this warning will reduce the effectiveness of the airbag or potentially dislodge the equipment, causing serious injury or death.

Preparing the Mounting Area

To prepare the Ford Interceptor spoiler for the MPS6 lights:

1. Following the vehicle manufacturer instructions, remove the rear spoiler assembly.
2. See Figure 1. Position the brackets as shown and mark the six mounting hole locations and two wire routing hole locations. Note that brackets and mounting are symmetric.
3. Using a 3/16 in drill bit, drill the mounting holes through the two outer layers (approximately 1/4 in deep).
4. Drill the appropriate wire routing holes in the spoiler.
5. Drill an 11/16 in wire routing hole in the tailgate in the location shown in Figure 1.

Installing Six Spoiler-Mounted MicroPulse 6 Lighthoods

6. Mount the brackets with 1/4 in hex-head screws and 1/4 in lockwashers. Do not over tighten.
7. Install the lighthoods (not included) to both brackets with the supplied 6-32 screws and Keps nuts.
8. Complete the wiring per the instructions supplied with the lighthoods. Using the supplied grommet, route the wires through the hole drilled in Step 5 and the flex joint into the cabin. DO NOT route wires through any existing holes. A disconnect appropriate for the wiring may make spoiler installation easier. Seal the grommet and all openings made during the install with sealer noted above.

Figure 1 Position of brackets

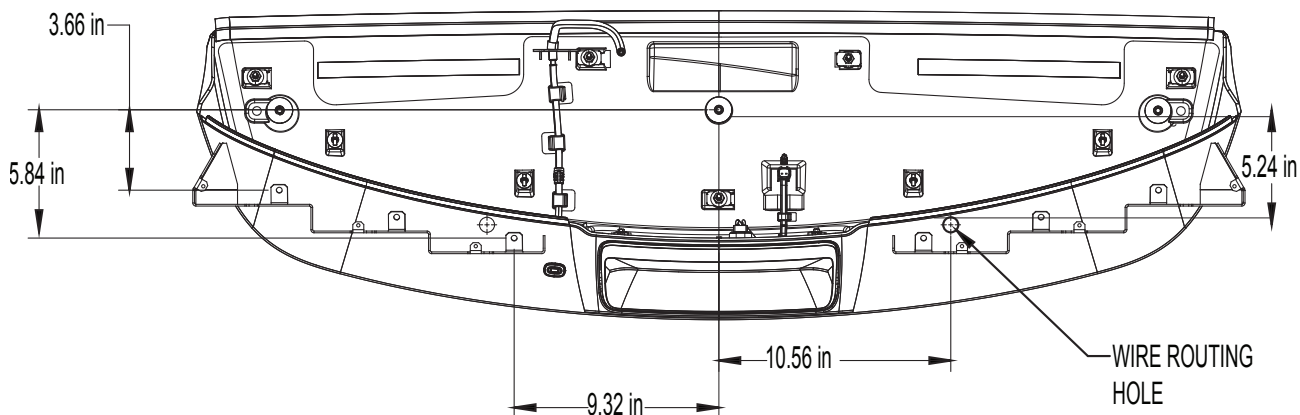
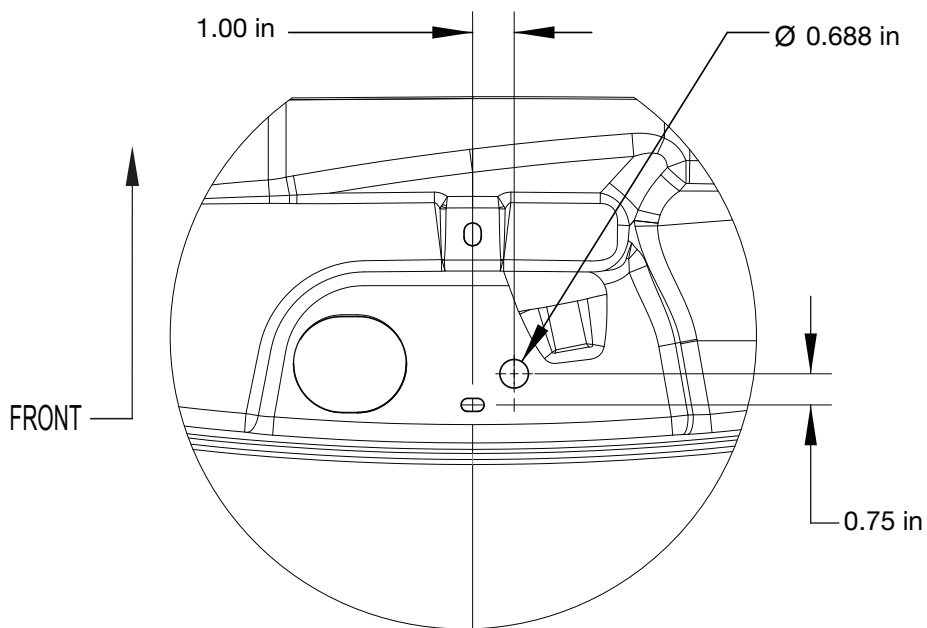
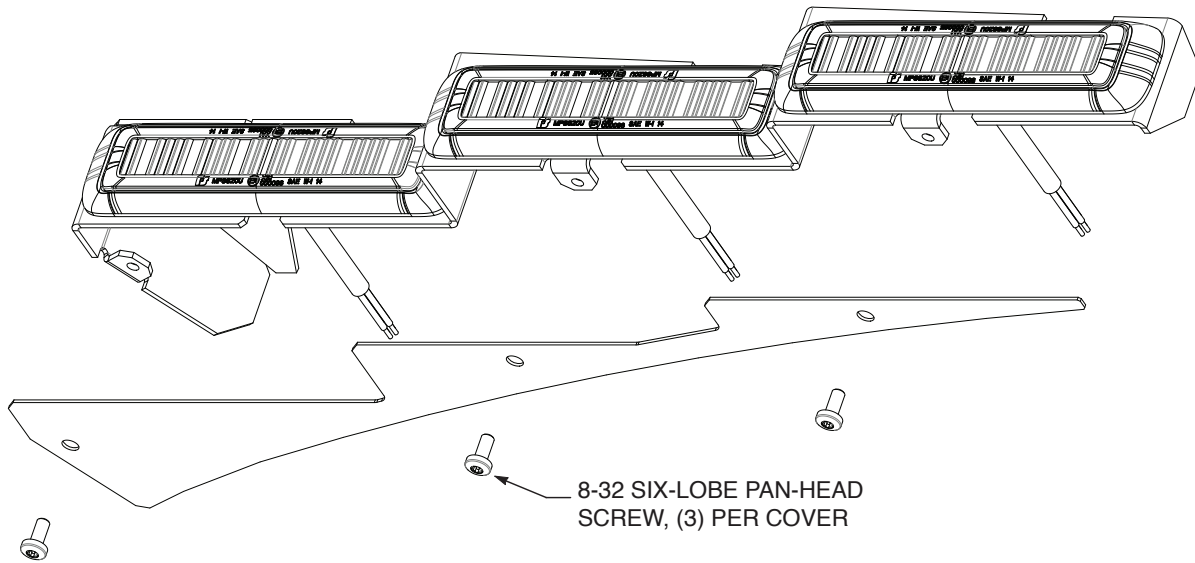

Figure 2 Drill an 11/16 in wire routing hole



9. See Figure 3 on page 4. Install the cover plates with the black 8-32 thread-forming screws.

Figure 3 Install the cover plates



10. Cut the supplied gasket into four equal pieces (Figure 4) and mount to the back glass (Figure 5).

11. Install Ford Liftgate Spoiler Kit Part # HB5Z-78442K03-A (FSC 7770892).

Figure 4 Gasket cut into four equal pieces

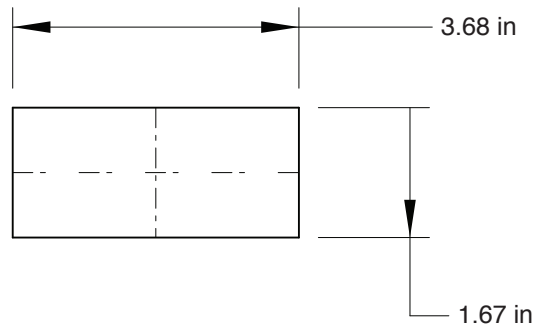
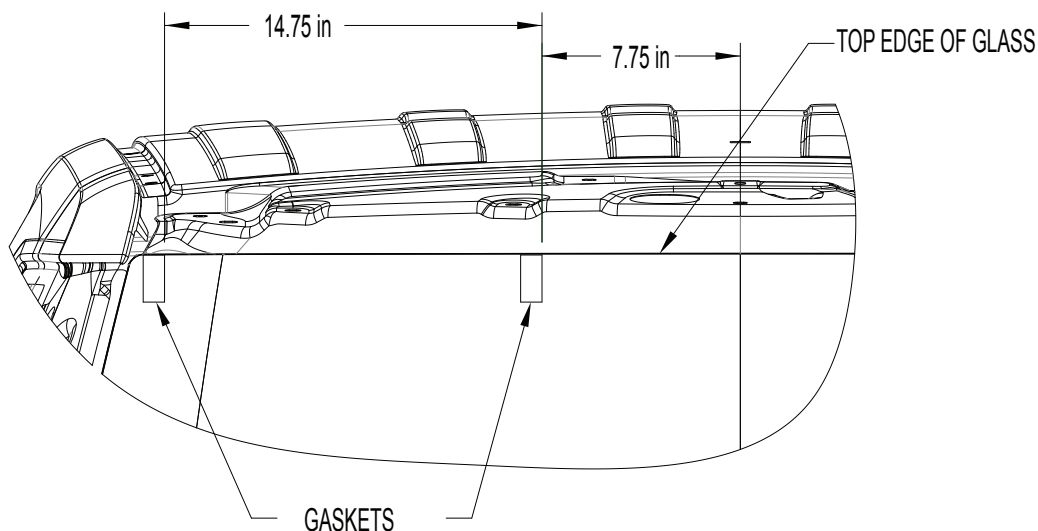

Figure 5 Mount gasket to the back glass



12. Reinstall the spoiler per the vehicle manufacturer instructions. Ensure that the spoiler/bracket assembly sits flush against the vehicle liftgate.
13. Test the lights for proper operation.

⚠ WARNING

LIGHT HAZARD: *To be an effective warning device, an emergency warning system produces bright light that can be hazardous to your eyesight when viewed at close range. Do not stare directly into the lights at a close range or permanent damage to your eyesight may occur.*

Getting Technical Support and Service

The Federal Signal factory provides technical assistance with any problems that cannot be handled locally. Any units returned to Federal Signal for service, inspection, or repair must be accompanied by a Return Material Authorization (RMA). Obtain a RMA from a local distributor or manufacturer's representative. Please provide a brief explanation of the service requested or the nature of the malfunction.

For technical support and service, visit:

<https://www.fedsig.com/technical-support>

<https://www.fedsig.com/service-centers>

Limited Warranty

This product is subject to and covered by a limited warranty, a copy of which can be found at www.fedsig.com/SSG-Warranty. A copy of this limited warranty can also be obtained by written request to Federal Signal Corporation, 2645 Federal Signal Drive, University Park, IL 60484, email to info@fedsig.com or call +1 708-534-3400.

This limited warranty is in lieu of all other warranties, express or implied, contractual or statutory, including, but not limited to the warranty of merchantability, warranty of fitness for a particular purpose and any warranty against failure of its essential purpose.



2645 Federal Signal Drive
University Park, Illinois 60484

www.fedsig.com

Customer Support

Police/Fire-EMS: 800-264-3578 • +1 708 534-3400

Work Truck: 800-824-0254 • +1 708 534-3400

Technical Support 800-433-9132 • +1 708 534-3400