



**FEDERAL SIGNAL**  
Safety and Security Systems

# **Model SIFMHVHL-IU17 Mounting Kit**

---

## ***Installation Instructions***

25500420  
Rev. A0 0717  
Printed in U.S.A.

© 2017 Federal Signal Corporation. All rights reserved.

## Limited Warranty

This product is subject to and covered by a limited warranty, a copy of which can be found at [www.fedsig.com/SSG-Warranty](http://www.fedsig.com/SSG-Warranty). A copy of this limited warranty can also be obtained by written request to Federal Signal Corporation, 2645 Federal Signal Drive, University Park, IL 60484, email to [info@fedsig.com](mailto:info@fedsig.com) or call +1 708-534-3400.

This limited warranty is in lieu of all other warranties, express or implied, contractual or statutory, including, but not limited to the warranty of merchantability, warranty of fitness for a particular purpose and any warranty against failure of its essential purpose.



**FEDERAL SIGNAL**  
Safety and Security Systems

2645 Federal Signal Drive  
University Park, Illinois 60484-3167

[www.fedsig.com](http://www.fedsig.com)

Customer Support

Police/Fire-EMS: 800-264-3578 • +1 708 534-3400

Work Truck: 800-824-0254 • +1 708 534-3400

Technical Support 800-433-9132 • +1 708 534-3400

---

## Contents

<b>Safety Messages to Installers and Operators of Warning Light Equipment</b> .....	<b>5</b>
<b>Product Overview</b> .....	<b>6</b>
<b>Unpacking the Kit</b> .....	<b>6</b>
<b>Getting Technical Support and Service</b> .....	<b>12</b>

### Tables

<b>Table 1</b> SIFMHVHL-IU17 Items Installed at Factory .....	<b>6</b>
<b>Table 2</b> SIFMHVHL-IU17 Replacement Items Installed by User.....	<b>7</b>

### Figures

<b>Figure 1</b> Drill 4 holes in vehicle.....	<b>9</b>
<b>Figure 2</b> Drill 4 holes in trim panel .....	<b>10</b>
<b>Figure 3</b> ILS system with mounting bracket.....	<b>11</b>

---

© 2017 Federal Signal Corporation  
Ford is a registered trademark of Ford Motor Company.  
Keps a registered trademark of Shakeproof division of Illinois Tool Works Inc.

---

*Model SIFMHVHL-IU17 Mounting Kit*

## **Safety Messages to Installers and Operators of Warning Light Equipment**

### **⚠ WARNING**

People's lives depend on your proper installation and operation of Federal Signal products. It is important to read, understand and follow all instructions shipped with the products and the original product. In addition, listed below are some other important safety instructions and precautions you should follow:

- To properly install this light, you must have a good understanding of automotive electrical procedures and systems along with proficiency in the installation and use of safety warning equipment. Always refer to the vehicle's service manuals when installing equipment on a vehicle.
- DO NOT install equipment or route wiring in the deployment path of an airbag.
- When drilling into a vehicle structure, be sure that both sides of the surface are clear of anything that could be damaged.
- For the light to function properly, a separate ground connection must be made. If practical, it should be connected to the negative battery terminal. At a minimum, it may be attached to a solid metal body or chassis part that provides an effective ground path.
- Locate the light control so the VEHICLE and CONTROL can be operated safely under all driving conditions.
- The effectiveness of an interior mounted warning light depends on the clarity, the tinting, and the angle of the glass it is being placed behind. Tinting, dirt defects, and steeply angled glass reduce the light output of the warning light. This may reduce the effectiveness of the light as a warning signal. If your vehicle has dirty, tinted, or steeply angled glass, use extra caution when driving your vehicle or blocking the right of way with your vehicle.
- Do not attempt to activate or deactivate the light control while driving in a hazardous situation.
- You should frequently inspect the light to ensure that it is operating

## ***Installation Instructions***

---

properly and that it is securely attached to the vehicle.

- This product contains high intensity LED devices. To prevent eye damage, DO NOT stare into the light beam at close range.
- After installation, test the stick light to ensure that it is operating properly.
- If a vehicle seat is temporarily removed, verify with the vehicle manufacturer if the seat needs to be recalibrated for proper airbag deployment.
- After testing is complete, provide a copy of these instructions to the instructional staff and all operating personnel.
- File these instructions in a safe place and refer to them when maintaining and/or reinstalling the product.

Failure to follow all safety precautions and instructions may result in property damage, serious injury, or death.

### **Product Overview**

This publication contains instructions for installing an ILS system into the rear hatch of a 2017 Ford® Police Interceptor Utility.

**NOTE:** For electrical installation instructions, refer to the Installation and Maintenance Instructions packed with the lights.

### **Unpacking the Kit**

After unpacking the kit, inspect it for damage that may have occurred in transit. If it has been damaged, file a claim immediately with the carrier, stating the extent of damage. Carefully check all envelopes, shipping labels, and tags before removing or destroying them. If you are missing any parts, contact Customer Support at 1-800-264-3578, 7 a.m. to 5 p.m., Monday through Friday (CT).

**Table 1** SIFMHVHL-IU17 Items Installed at Factory

<b>Qty.</b>	<b>Description</b>	<b>Part Number</b>
1	Shroud Assembly, Hatch, FPIU, SIFMH	862402061
1	Cover, Hatch, FPIU, SIFMH	862402062
1	Screw, Type TT, 8-32, Pan Head, Torx, Steel, Black Zinc	70000143-06

**Table 2** SIFMHVHL-IU17 Replacement Items Installed by User

Qty.	Description	Part Number
1	Bracket, Assembly, Upper, Hatch, FPIU, SIFMH	862402064
1	Bracket, Assembly, Lower, Hatch, FPIU, SIFMH	862402066
8	Nut, Hex Ext Keps® Stl 1/4-20	7058A005
12	Washer, Flat, Stl, .266 x 5/8 x .063	7072A028
1	Trim Seal, 1/16 Edge, 6 mm Bulb	77700500-56
1	Fuse Kit	8620006-01
4	Nut, Jack Nut, 1/4-20, Steel, Zinc	70500830
4	Dome Plug, 3/4" Nylon	231224
4	Bolt, Cap, 1/4-20, Hex, Stl, Zinc, Clear	7002A000-14

## Installing the Warning Lights

**WARNING**

**AIRBAG DEPLOYMENT:** Do not install equipment or route wiring in the deployment path of an airbag. Failure to observe this warning will reduce the effectiveness of the airbag or potentially dislodge the equipment, causing serious injury or death.

**IMPORTANT:** Plan all cable routing before the installation.

**DRILLING PRECAUTIONS:** When drilling holes, check the area you are drilling into to be sure you do not damage vehicle components. All drilled holes should be deburred and all sharp edges should be smoothed. All wire routings going through drilled holes should be protected by a grommet or convolute/split loom tubing

To install the warning lights:

1. Install the extruded-rubber sealing strip on the edges of the shroud and cover that contact the rear window.
2. Remove trim panel from vehicle.
3. Drill (4) 7/16" holes in vehicle in locations as shown in Figure 1 by using the upper bracket as a template.
4. Loosely install 1/4" bolts, washers, and jack nuts onto upper bracket.

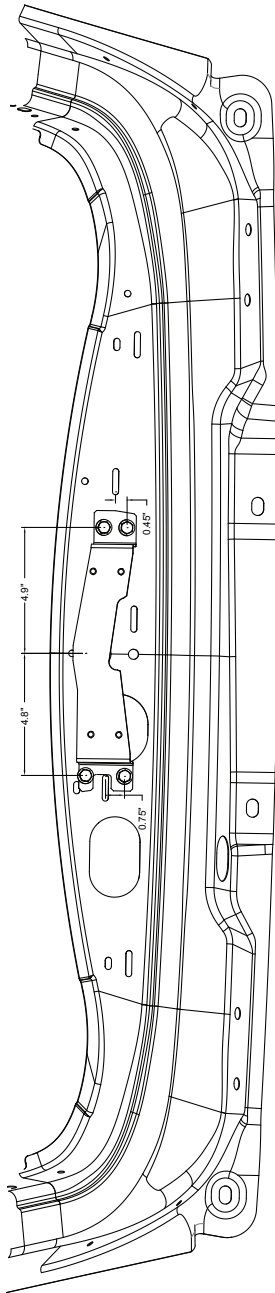
## ***Installation Instructions***

---

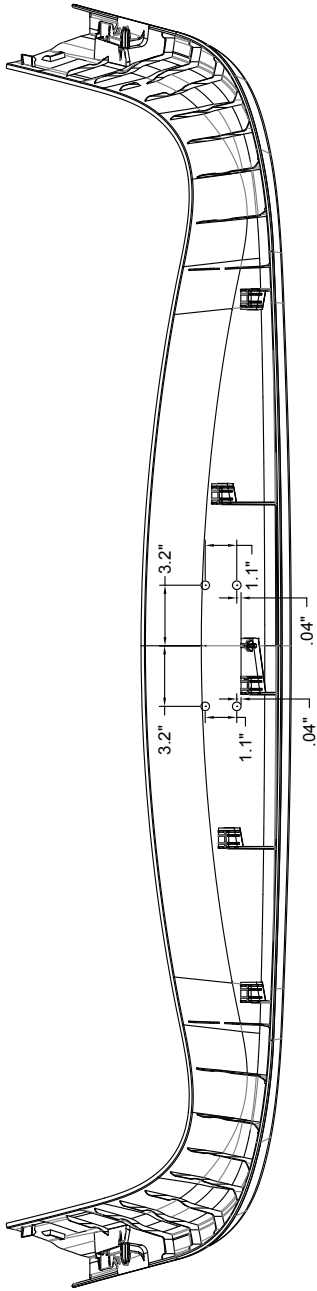
5. Install bracket into previously drilled holes in vehicle and tighten bolts until jack nuts are fully collapsed. Do not over-tighten bolts.
6. Drill (4) 3/8" holes in trim panel in the locations shown in Figure 2. Reinstall trim panel.
7. Install lower bracket to upper bracket using the supplied Keps nuts and flat washers.
8. Loosely install ILS unit to lower bracket using the supplied Keps nuts and flat washers. Slide housing forward until the edge of the housing contacts the glass. Tighten the Keps nuts. Do not over-tighten keps nuts. Install the (4) nylon plugs. See Figure 3.



Figure 1 Drill 4 holes in vehicle

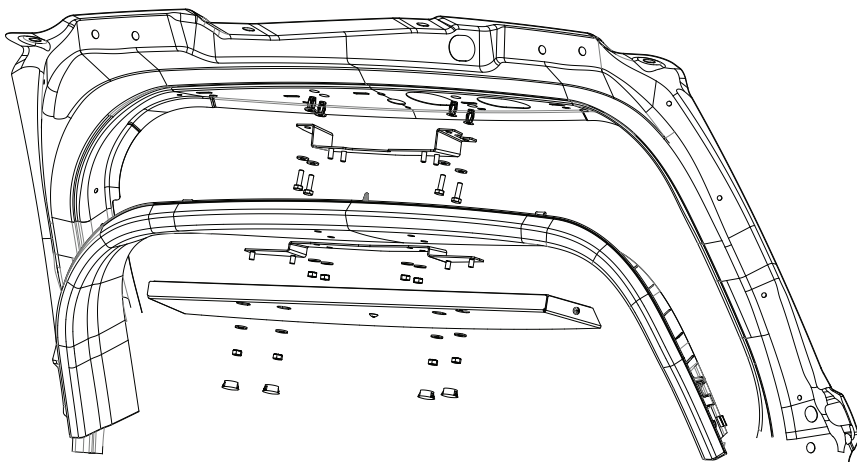


**Figure 2** Drill 4 holes in trim panel



---

**Figure 3** ILS system with mounting bracket



## Wiring the Installation

Refer to the Installation and Maintenance Instructions packed with speaker and lights.

## Testing the Warning System

### **⚠ WARNING**

**SOUND HAZARD:** *All effective sirens and horns produce loud sounds (120 dB) that may cause permanent hearing loss. Always minimize your exposure to the sound of the siren or horn, and wear hearing protection. Do not sound the siren or horn indoors or in enclosed areas where you and others will be exposed to the sound.*

**LIGHT HAZARD:** *To be an effective warning device, an emergency warning system produces bright light that can be hazardous to your eyesight when viewed at a close range. Do not stare directly into this lighting product at a close range or permanent damage to your eyesight may occur.*

After testing the flasher, test the emergency warning system to ensure that it is operating properly. Also test all vehicle functions, including horn operation, vehicle safety functions, and vehicle lighting systems to ensure proper operation. Ensure that the installation has not affected the vehicle operation or changed any vehicle safety functions or circuits.

## ***Installation Instructions***

---

After testing is complete, provide a copy of these instructions to the instructional staff and all operating personnel.

Do not test the sound and light system of the vehicle while driving. Operating the vehicle warning systems may pose a hazard to the operator and other drivers if the systems do not function as expected. Test the vehicle only in a controlled environment.

### **Getting Technical Support and Service**

For technical support and service, please contact:

Service Department  
Federal Signal Corporation  
Phone: 1-800-433-9132  
Fax: 1-800-343-9706  
Email: [empserviceinfo@fedsig.com](mailto:empserviceinfo@fedsig.com)  
[www.fedsig.com](http://www.fedsig.com)

### **Getting Repair Service**

The Federal Signal factory provides technical assistance with any problems that cannot be handled locally.

Any units returned to Federal Signal for service, inspection, or repair must be accompanied by a Return Material Authorization (RMA). Obtain a RMA from a local Distributor or Manufacturer's Representative.

Provide a brief explanation of the service requested, or the nature of the malfunction.

Address all communications and shipments to the following:

Federal Signal Corporation  
Service Department  
2645 Federal Signal Drive  
University Park, IL 60484-3167

### **Ordering Replacement Parts**

To order replacement parts, call Customer Support at 1-800-264-3578, 7 a.m. to 5 p.m., Monday through Friday (CT) or contact your nearest distributor.