



FEDERAL SIGNAL

Safety and Security Systems / **Industrial**

MODEL 24XST Series
INSTALLATION AND SERVICE INSTRUCTIONS
FOR FEDERAL SIGNAL
MODELS 24XSTHI and 24XSTHI-CN
VISUAL SIGNAL APPLIANCES FOR
USE IN HAZARDOUS LOCATIONS

Limited Warranty

This product is subject to and covered by a limited warranty, a copy of which can be found at www.fedsig.com/SSG-Warranty. A copy of this limited warranty can also be obtained by written request to Federal Signal Corporation, 2645 Federal Signal Drive, University Park, IL 60484, email to info@fedsig.com or call +1 708-534-3400.

This limited warranty is in lieu of all other warranties, express or implied, contractual or statutory, including, but not limited to the warranty of merchantability, warranty of fitness for a particular purpose and any warranty against failure of its essential purpose.



2645 Federal Signal Drive
University Park, Illinois 60484-3167

www.fedsig.com

Customer Support 800-344-4634 • +1 708 534-3400

Technical Support 800-524-3021 • +1 708 534-3400

**INSTALLATION AND SERVICE INSTRUCTIONS FOR FEDERAL
MODEL 24XST SERIES VISUAL SIGNAL APPLIANCES
FOR USE IN HAZARDOUS LOCATIONS**

 SAFETY MESSAGE TO INSTALLERS, USERS AND MAINTENANCE PERSONNEL

It is important to follow all instructions shipped with this product. This device is to be installed by a trained electrician who is thoroughly familiar with the National Electrical and Fire Codes and will follow all local codes.

This device should be considered a part of the warning system and not the entire warning system.

The selection of the mounting location for the device, its controls and the routing of the wiring are to be accomplished under the direction of the facilities engineer and the safety engineer. In addition, listed below are some other important safety instructions and precautions you should follow:

- Read and understand all instructions before installing or operating this equipment.
- Never alter the unit in any manner. Safety in hazardous locations may be endangered if additional openings or other alterations are made in units specifically designed for use in these locations.
- Do not connect this light to the system when power is on.
- After installation, ensure that all threaded joints are properly tightened.
- Keep the unit tightly closed when in operation.
- After installation, test the light system to ensure that it is operating properly.
- After testing is complete, provide a copy of this instruction sheet to all personnel.
- Establish a procedure to routinely check the light system for proper activation and operation.
- Do not change the factory-applied finish.

Failure to follow all safety precautions and instructions may result in property damage, serious injury, or death.

I. GENERAL

The Model 24XSTHI strobe light is a Visual Signaling Device for Hearing Impaired for use in Hazardous Locations and provides about 63 high-intensity flashes per minute. The unit is UL Listed for indoor use on a wall or pendant in a nonsleeping area and complies with TYPE 4X (watertight and corrosion resistant) enclosure requirements and Marine Visual Signal Device (saltwater).

The Model 24XSTHI-CN strobe light is a Visual Signaling Appliance, Fire Alarm for Use in Hazardous Locations and provides about 63 high-intensity flashes per minute. The unit is ULC Listed for indoor/outdoor use on a wall or pendant in a nonsleeping area and complies with TYPE 4X (watertight and corrosion resistant) enclosure requirements.

For the Electrical Ratings, see Table 1. See Figure 1 on page 7 for the light dispersion of the 24XSTHI. See Figure 1A on page 8 for the light dispersion of the Model 24XSTHI-CN.

Table 1 Electrical Ratings

Operational Voltage Range*	16–33 Vdc
On-Axis Candelas	30
Flashes/minute	63 ± 2
Frequency, Hz	DC
Max. DC Operating Current, A	1.02

*Underwriters Laboratories only evaluated this product to the stated operational voltage range. It was not evaluated to 80% to 110% of the voltage range.

Table 2 Environmental Ratings

AMBIENT TEMPERATURE RANGE: -40°C to +66°C		
LOCATION	T-CODE @ 40°C MAX.	T-CODE @ 66°C MAX.
CLASS I, DIV. 1 AND 2, GRPS C AND D	85°C/T6	85°C/T6
CLASS I, DIV. 2, GRPS A AND B	135°C/T4	160°C/T3C
CLASS II, DIV. 1, GRPS E, F, AND G	85°C/T6	120°C/T4A
CLASS III	85°C/T6	120°C/T4A

This equipment is suitable for Class I, Division 1, Groups C and D; Class I, Division 2, Groups A, B, C and D, Class II, Division 1, Groups E, F and G; Class III and non-hazardous locations.

This device is intended for permanent installation and operation in accordance with Title 46, Code of Regulations, Parts 110-113, or Title 33, Code of Federal Regulations Part 183, Sub-part I, Section 183.410, and the applicable requirements of the American Boat and Yacht Council, Inc. and/or ANSI/NFPA 302, “Fire Protection Standard for Pleasure and Commercial Motor Craft.”

▲WARNING

EXPLOSION HAZARD—This light fixture is not backward compatible with older products. Do not use this light fixture with the Series A versions of model CMXC, CMXC-R, PMXC, PMXC-R, WMXC, or WMXC-R mounting accessories. Failure to follow this warning may result in personal injury or death.

II. INSTALLATION

A. Unpacking the Product

▲WARNING

EXPLOSION HAZARD — Damaged glass domes can lead to explosions, which could result in serious injury or death. Replace damaged domes.

After unpacking the unit, examine it for damage that may have occurred in transit. If the equipment has been damaged, do not attempt to install or operate the unit. File a claim immediately with the carrier, stating the extent of damage. Carefully check all envelopes, shipping labels and tags before removing or destroying them.

B. *Mounting*

The Model 24XSTHI strobes are designed for hearing impaired applications and should be installed per the NFPA 70 and 72, STATE and LOCAL CODES. Alternate installation locations and/or orientations should only be performed with the approval of the authority having jurisdiction. See Figure 1 on page 7 for the light dispersion of the 24XSTHI.

The Model 24XSTHI-CN strobes are designed for fire alarm and signaling systems per CSA CC22.1, Canadian Electrical code. Figure 1A on page 8 for the light dispersion of the 24XSTHI-CN

See Figure 3 on page 10. Install the ceiling mount on the support surface using the four external mounting slots.

Remove the terminal block from the ceiling mount by loosening the two mounting screws.

C. *Electrical Connections*



SHOCK HAZARD — To avoid electrical shock hazards, do not connect wires when power is applied.

The DC Model's Operating Voltage Range Limits: 16 Vdc to 33 Vdc.



TESTED LIMITS — This product was only tested to its rated operating voltage range. It was not tested to 80% and 110% of these limits.

CAUTION

REVERSE POLARITY/MISWIRING — The DC units are polarity sensitive, and MAY BE DAMAGED by incorrect electrical hookup. When connecting the DC strobe unit to the voltage supply lines, POLARITY MUST BE OBSERVED. In addition, damage will result if the voltage rating of the model is exceeded.

Model 24XST units are provided with incoming and outgoing power-connection terminals to allow electrical supervision. See Figure 4 on page 10.

1. Connect the incoming (+) positive side of the power source to the terminal marked "L+" and the outgoing (+) positive power source to the terminal marked "B."

2. Connect the incoming (-) negative side of the power source to the terminal marked "N-" and the outgoing (-) negative side of the power source to the terminal marked "A."

3. If required by local building codes, connect the earth ground wire to the green screw in the fixture mount.

4. Use 18 AWG wire or larger.

D. To prevent galling and ease future maintenance, ensure that the ceiling mount threads are clean and lubricated. Thread the fixture clockwise into the ceiling mount and tighten it securely.

III. MAINTENANCE



RISK OF ELECTRIC SHOCK — High voltages are present inside the light assembly after disconnecting power. To prevent receiving an electrical shock, disconnect the fixture from the supply circuit and wait at least 5 minutes before opening.



EXPLOSION HAZARD — Do not disconnect the equipment while the circuit is live or unless the area is known to be free of ignitable concentrations.

EXPLOSION — Ne pas débrancher l'équipement tout en le circuit est sous tension ou si la zone est connue pour être libre de concentrations inflammables.



EXPLOSION HAZARD — Substitution of any component may impair suitability for Class I, Division 2. Keep the unit tightly closed when in operation.



EXPLOSION HAZARD — Do not remove or replace any component inside the enclosure unless power has been disconnected or the area is free of ignitable concentrations.

RISQUE D'EXPLOSION — Ne pas retirer ou de remplacer tout composant à l'intérieur de l'enceinte, à moins que l'alimentation a été débranché ou que la zone est libre de concentrations inflammables.

SAFETY MESSAGE TO MAINTENANCE PERSONNEL

Listed below are some important safety instructions and precautions you should follow:

- Read and understand all instructions before operating this system.
- Any maintenance to the light system must be done with the power turned off.
- Any maintenance to the light system must be performed by a trained electrician in accordance with all applicable national and local codes in the country of use.
- Never alter the unit in any manner. The safety of the unit may be compromised if additional openings or other alterations are made.

- The nameplate should not be obscured, it contains cautionary and/or other information of importance to maintenance personnel. Ensure the nameplate remains readable if the housing's exterior is painted.
- If the glass dome is damaged in any way, it **MUST** be replaced.
- After performing any maintenance, test the light system to ensure that it is operating properly.

Failure to follow all safety precautions and instructions may result in property damage, serious injury, or death to you or others.

A. *Flash Tube Replacement*

As strobe lights are used, the flash tubes begin to darken, causing the light output to decrease. This darkening is characteristic of flash tubes. The darkening will begin near the base of the tube and progress upward. In addition, as flash tubes age, they may have a tendency to misfire (not fire periodically).

After extended operation, occasionally check for flash tube degradation. Should the flash tube misfire, have a noticeable decrease in light output, glow continuously or darken to a point beyond that shown in Figure 5 on page 11, it should be replaced.



SHOCK HAZARD — Strobe and HID light systems generate high voltages. Disconnect power and wait 5 minutes before opening the unit. Failure to follow this warning could result in serious injury or death.



HANDLE STROBE LAMPS CAREFULLY — Strobe lamps get hot enough to burn you. Always allow these lamps to cool before handling them. Strobe lamps are also pressurized and, if broken, can result in flying glass. Failure to follow this warning may result in personal injury.



DO NOT TOUCH LAMP WITH BARE HANDS — Oil deposits on the glass portion of the strobe lamp can cause the glass to fracture during use. If you are unsure if the glass has been handled without gloves, clean the glass using a soft cloth and isopropyl alcohol before installing the lamp.



HANDLE STROBE AND HALOGEN LAMPS CAREFULLY — Strobe and halogen lamps get hot enough to burn you. Always allow these devices to cool before handling them. Halogen and strobe lamps are also pressurized and if broken can result in flying glass. Always wear gloves and eye protection when handling these devices. Failure to follow this caution may result in personal injury.

To change the flash tube:

1. Disconnect power.
2. Remove the glass dome assembly from the main casting by rotating the dome assembly counterclockwise.

▲WARNING

EXPLOSION HAZARD — The effectiveness of the explosion-proof enclosure must be maintained. Do not damage the dome or threads while disassembling or reassembling the unit. Lubricated joints exposed for long periods of time may attract small particles of dirt or other foreign materials. Body and cover joints should be reassembled immediately.

3. Gently pull the flash tube from its socket. A rocking motion is most helpful when installing or removing the tube.
4. Replace the flash tube with the appropriated replacement part listed in part listed in paragraph III. E. Replacement Parts on page 7.
5. Replace the dome assembly and tighten it securely.

B. *Cleaning the Enclosure*

NOTE

Maintenance procedures sometime require fixtures to be hosed down for good housekeeping. The circuit must be turned OFF and fixture dome MUST be allowed to cool to ambient room temperature before cleaning.

The fixture should be cleaned periodically to maintain maximum light output. Only mild, non-abrasive cleaning agents should be used. The glass dome should be regularly inspected for scratches and chips, and if damaged, must be replaced.

C. *Lubrication*

The threaded joints should be kept well lubricated with a corrosion-inhibiting grease such as petrolatum or soap-thickened mineral oils. If corrosive products have accumulated on the explosion-proof joints and cannot readily be removed with solvents, the parts should be discarded and replaced.

▲WARNING

EXPLOSION HAZARD — Never use an abrasive material or file to remove corrosive products from threaded surfaces. In extremely corrosive locations, equipment should be periodically inspected to guard against unusual deterioration and possible porosity, since this may weaken the enclosure structurally.

D. *Service*

Federal Signal will service your equipment and provide technical assistance with any problems that cannot be handled locally by Federal Signal's Distributor or Manufacturer Representative.

Any unit returned to Federal Signal for service, inspection, or repair must be accompanied by a Return Material Authorization number with a brief explanation of the service being requested and/or the nature of the malfunction. This R.M.A. can be obtained from the local Federal Signal Distributor or Manufacturer's Representative.

<https://www.fedsig.com/service-centers>

E. *Replacement Parts*

Description

Flash Tube
 Assembly, Glass Dome
 PCBA Low-Inrush
 Mechanism, 24 Vdc

Part Number

K8107159
 K8436147
 K2001918
 K8436107-06

F. *Optional Accessories*

Description

Pendant Mount, Red
 Wall Mount, 4-Wire, Red
 Dome Guard

Model

PMXC-R-SB
 WMXC-4R-SB
 DGXC-SB

1

Model 24XSTHI Visible Signaling Device for the Hearing
 Impaired Light Dispersion Pattern per UL1971

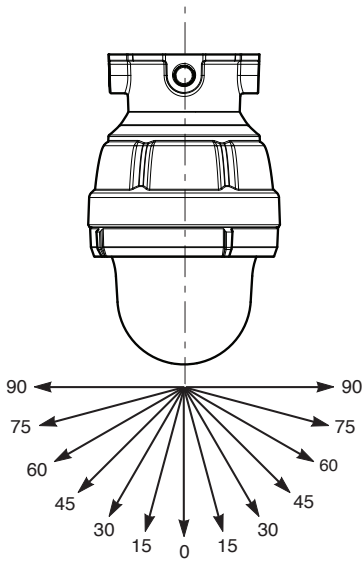

Horizontal Light Dispersion Pattern	
Degrees (°)	Minimum Output (cd)
0	30.0
5-25	27.0
30-35	22.5
50	16.5
55	13.5
60	12.0
65	10.5
70	10.5
75	9.0
80	9.0
85	7.5
90	7.5

1A

Model 24XSTHI-CN Visible Signaling Device Light Dispersion
 Pattern per UL1971

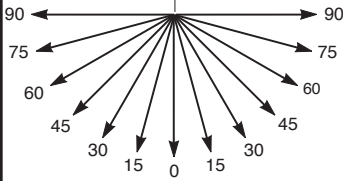
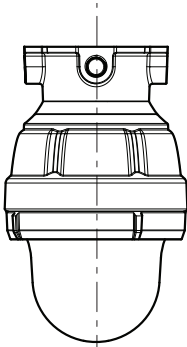

Degrees (°)	Minimum) ULC Requirement	Measured Output (Representative of both X and Y Planes) % of Candela Rating
±0	100	281
±5	90	303
±10	90	307
±15	90	319
±20	90	315
±25	90	304
±30	75	377
±35	75	331
±40	75	257
±45	75	268
±50	55	429
±55	45	579
±60	40	682
±65	35	750
±70	35	602
±75	30	796
±80	30	844
±85	25	1040
±90	25	696
Com- pound ±45	24	1117

2

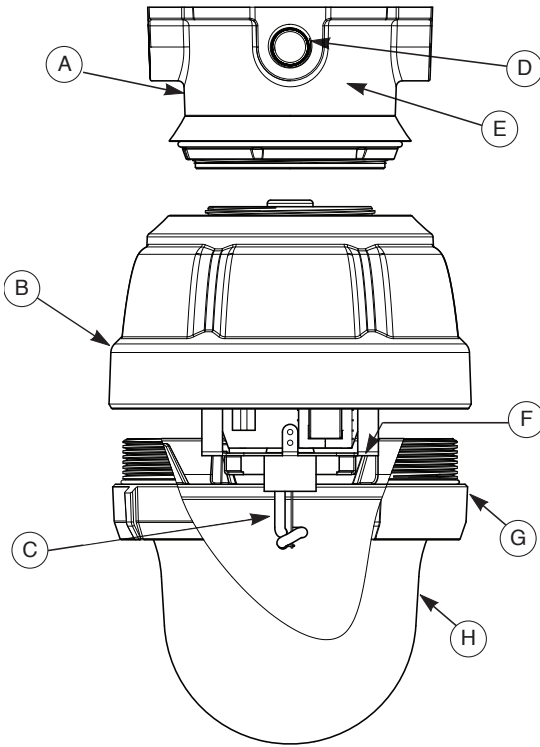

A. Ceiling Mount
B. Main Housing
C. Strobe Flash Tube
D. 3/4" NPT Conduit
E. Terminal Block
F. Mechanism Assembly
G. Glass Dome Assembly
H. Glass Dome

3

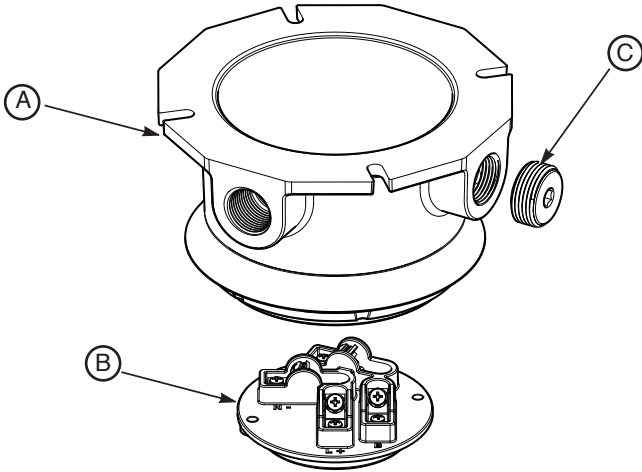

- A. Not suitable for use with through branch circuit conductors.
- B. Terminal block
- C. NPT closure plug

4

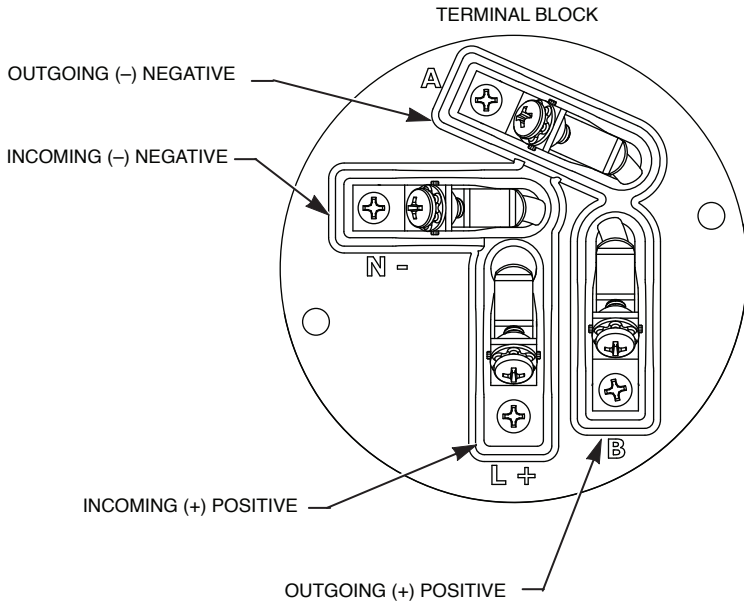

5

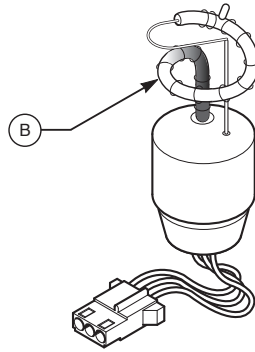
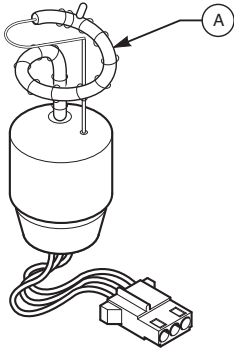

A. New flash tube.

B. Used flash tube tends to discolor in areas shown and should be replaced.

