



"BP" SERIES SPEAKERS



BP100



BP200

Available in 100 or 200-watt versions, the BP series of speakers is the versatile choice for audible warning.

Constructed of a sturdy, cast aluminum housing, the BP series of speakers are designed to perform in all weather conditions and are also compatible with most Federal Signal sirens.

Revolutionary Design

The dual diverging manifold design of the BP100 and BP200 projects sound more uniformly than conventional speakers. This means more sound projection to both sides, as well as to the front of the vehicle.

BP100

The patented design of the BP100 allows sound to project forward and effectively reduced compartment noise. The BP100 also complies with Class A specifications when used with a Federal Signal siren.

BP200

The BP200 speaker incorporates two 100-watt neodymium drivers to produce a full 200-watts of output. Designed to attractively flush mount through the bumper of a vehicle, the BP200 is available with a choice of two grilles. The BP200-EF includes a polished, stainless steel "Electric F" grille. The BP200-Q includes a backplate and the classic chrome plated "Q" grille, which is a staple in the fire industry.

Installation

The BP series of compact speakers is available with a variety of mounting options to perfectly fit specific applications. Choose from a selection of BP100 mount kits or select a BP200 model, which includes an integral mounting bracket and hardware.

> Features

- Convenient installation options.
- Unique design projects sound to the front as well as to the sides of the vehicle.

> Approval

- 100-watt speaker meets Class A standards when used with any Federal Signal siren.

> How to Order

Specify Model

- BP100** 100-watt, compact speaker, black
- BP200-EF** 200-watt speaker, mount with "Electric F" grille
- BP200-Q** 200-watt speaker, mount with classic "Q" grille and backplate

When ordering BP100 order a mounting kit.

- BPGR** Standard behind-the-grille mount kit
- BPMT** Standard bumper mount kit

	BP100	BP200-EF	BP200-Q
Specifications			
Power	100W	200W	200W
Physical Specifications			
Height	5.5 in (14.0 cm)	5.5 in (14.0 cm)	5.5 in (14.0 cm)
Width	5.5 in (14.0 cm)	7.7 in (19.6 cm)	7.7 in (19.6 cm)
Depth	5.5 in (14.0 cm)	7.8 in (19.8 cm)	7.8 in (19.8 cm)
Shipping Weight			
	14 lbs (6.4 kg)	21 lbs (9.5 kg)	24 lbs (10.9 kg)

DIMENSIONAL DRAWINGS

BP200-Q Grille and Backplate

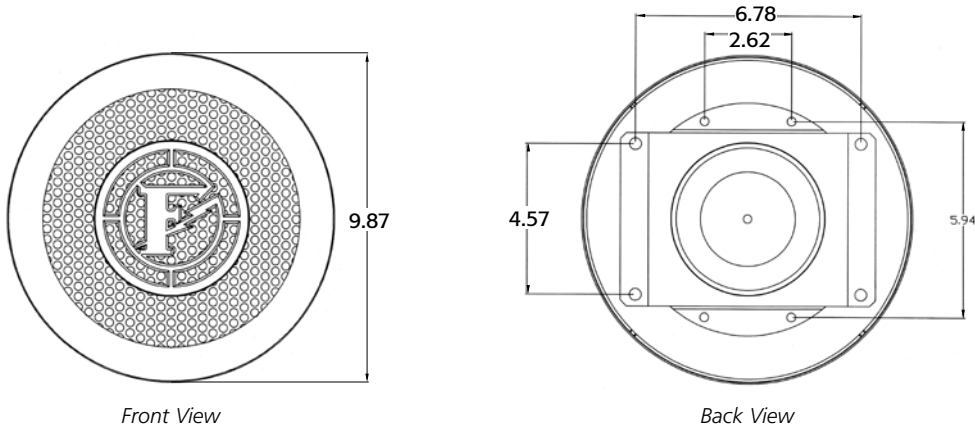

BP200-EF Grille

