

## INSTALLATION, OPERATING, AND MAINTENANCE INSTRUCTIONS FOR Q-SIREN MODELS Q2B-012P, Q2B-012NN, AND Q-MT

### SAFETY MESSAGE TO INSTALLERS

#### **WARNING**

The lives of people depend on your proper installation and servicing of Federal products. It is important to read and follow all instructions shipped with the products. In addition, listed below are some other important safety instructions and precautions you should follow:

#### *Before Installation*

##### *Qualifications*

- To properly install an electronic siren: you must have a good understanding of automotive electrical procedures and systems, along with proficiency in the installation and service of safety warning equipment. Always refer to the vehicle's service manuals when performing equipment installations on a vehicle.

##### *Sound Hazards*

- Your hearing and the hearing of others, in or close to your emergency vehicle, could be damaged by loud sounds. This can occur from short exposures to very loud sounds, or from longer exposures to moderately loud sounds. For hearing conservation guidance, refer to federal, state, or local recommendations. OSHA Standard 1910.95 offers guidance on "Permissible Noise Exposure."
- All effective sirens and horns produce loud sounds (120 dB) that may cause permanent hearing loss. Always minimize your exposure to siren sound and wear hearing protection. Do not sound the siren indoors or in enclosed areas where you and others will be exposed to the sound.
- Federal Signal siren amplifiers and speakers are designed to work together as a system. Combining a siren and speaker from different manufacturers may reduce the warning effectiveness of the siren system and may damage the components. You should verify or test your combination to make sure the system works together properly and meets federal, state and local standards or guidelines.

#### *During Installation*

- DO NOT get metal shavings inside the product. Metal shavings in the product can cause the system to fail. If drilling must be done near the unit, place an ESD approved cover over the unit to prevent metal shavings from entering the unit. Inspect the unit after mounting to be sure there are no shavings present in or near the unit.
- DO NOT connect this system to the vehicle battery until ALL other electrical connections are made, mounting of all components is complete, and you have verified that no shorts exist. If wiring is shorted to vehicle frame, high current conductors can cause hazardous sparks resulting in electrical fires or flying molten metal.
- Be sure the siren amplifier and speaker(s) in your installation have compatible wattage ratings.
- In order for the electronic siren to function properly, the ground connection must be made to the NEGATIVE battery terminal.

- Sound output will be severely reduced if any objects are in front of the speaker. If maximum sound output is required for your application, you should ensure that the front of the speaker is clear of any obstructions.
- Install the speaker(s) as far forward on the vehicle as possible, in a location which provides maximum signaling effectiveness and minimizes the sound reaching the vehicle's occupants. Refer to the National Institute of Justice guide 500-00 for further information.
- Mounting the speakers behind the grille will reduce the sound output and warning effectiveness of the siren system. Before mounting speakers behind the grille, make sure the vehicle operators are trained and understand that this type of installation is less effective for warning others.
- Sound propagation and warning effectiveness will be severely reduced if the speaker is not facing forward. Carefully follow the installation instructions and always install the speaker with the projector facing forward.
- DO NOT install the speaker(s) or route the speaker wires where they may interfere with the operation of air bag sensors.
- Installation of two speakers requires wiring speakers in phase.
- Never attempt to install aftermarket equipment, which connects to the vehicle wiring, without reviewing a vehicle wiring diagram - available from the vehicle manufacturer. Insure that your installation will not affect vehicle operation and safety functions or circuits. Always check vehicle for proper operation after installation.
- DO NOT install equipment or route wiring or cord in the deployment path of an air bag.
- Locate the control head so the vehicle, controls, and microphone can be operated safely.
- When drilling into a vehicle structure, be sure that both sides of the surface are clear of anything that could be damaged.

#### *After Installation*

- After installation, test the siren system and light system to ensure that it is operating properly.
- Test all vehicle functions, including horn operation, vehicle safety functions and vehicle light systems, to ensure proper operation. Ensure that installation has not affected vehicle operation or changed any vehicle safety function or circuit.
- After testing is complete, provide a copy of these instructions to the instructional staff and all operating personnel.
- File these instructions in a safe place and refer to them when maintaining and/or reinstalling the product.

Failure to follow all safety precautions and instructions may result in property damage, serious injury, or death to you or others.

**A. GENERAL.**

This instruction sheet provides directions for installation, operation, and maintenance of the Models Q2B-012P, Q2B-012NN, and Q-MT.

The Federal Q-Siren is a streamlined, chrome plated siren designed to provide reliable and long-life operation. The distinctive sound of the Q2B® electro-mechanical siren is a registered trademark owned by Federal Signal Corporation. A heavy duty coaster clutch and an electric brake are standard on all models.

**B. UNPACKING.**

After unpacking the siren, inspect it for damage that may have occurred in transit. If the unit has been damaged, do not attempt to install or operate it. File a claim immediately with the carrier, stating the extent of damage. Carefully check all envelopes, shipping labels and tags before removing or destroying them.

Before attempting to install the siren, ensure that the parts shown in the KIT CONTENTS LIST have been included.

**C. KIT CONTENTS LIST.**

Qty	Description	Part Number
1	Lug, 90A	224302
1	Grommet	8108A002
1	Grommet	8108A005
1	Terminal	506A001
1	Terminal	224A202A-07
3	Washer, Flat, 11/32, SS	7072A031
3	Bolt, 5/16-18, Hex Hd., SS	7002A005-24
3	Nut, 5/16-18, SS	7057A027
3	Lockwasher, 5/16, SS	7074A020

**D. INSTALLATION.**

**⚠ WARNING**

Electronically controlled transmissions may malfunction during operation of this siren. Consult the vehicle manufacturer BEFORE installing this siren in vehicles equipped with electronically controlled transmissions.

**⚠ WARNING**

Any attachment to the Q-Siren or other alteration of the product may reduce its ability to warn and may interfere with the Q-Siren's ability to meet applicable industry standards. Federal Signal does not recommend or approve the use of any sound focusing device or other attachments to the Q-Siren. The unauthorized use of a sound focusing device or other attachment could result in serious injury or death.

*1. Pedestal Mounting.*

Model Q2B-012P is designed to be installed on a flat surface. To install, proceed as follows:

a. Select a suitable mounting location which provides sufficient clearance on the under-side of mounting surface. Also, ensure that under-side of mounting surface is clear of any wires or brackets.

b. Using the supplied pedestal mounting hole template, scribe five drill position marks on the mounting surface (3 mounting holes and two holes for the grommets).

**⚠ WARNING**

Avoid damage to brake lines, fuel lines, electrical wiring, and other vital parts. When drilling or cutting on ANY part of the vehicle, ensure that both sides of the surface are clear of parts that could be damaged.

c. Drill three 11/32" holes at the mounting hole position marks. Drill two 17/32" holes at the position marks scribed for the grommet holes.

d. Install the grommets in the 17/32" holes drilled in step c. above. The grommet with the large hole is installed in the front hole and the grommet with the small hole is installed in the rear hole.

e. To ensure a good vehicle ground, scrape off the paint around the mounting holes on both sides of the mounting surface.

f. Route the power (4 AWG) and brake (12 AWG) leads through the grommets and the holes in the mounting surface.

**CAUTION**

The siren is heavy. Have someone assist you when lifting and positioning the unit.

g. Position the siren base over the mounting holes. Insert three 5/16-18 bolts through the holes in siren pedestal mounting bosses and mounting surface. Secure with flat washer, lockwasher and nut as shown in figure 1. Torque mounting bolts to 110-130 in./lbs.

*2. Flush Mounting.*

Model Q2B-012NN is designed to be flush mounted at the front of emergency vehicles. This mounting should only be attempted by emergency vehicle manufacturers; it is not recommended for local emergency vehicle service departments. Installation in the emergency vehicle should be in accordance with each vehicle manufacturers' specifications.

*3. Bumper Mounting.*

The Model Q2B-012NN can also be mounted in a bumper using a Model Q-MT bumper mounting kit. This mounting method should only be attempted by emergency vehicle manufacturers; it is not recommended for local emergency vehicle service departments. Installation in the emergency vehicle should be in accordance with each vehicle manufacturers' specifications.

**Q-MT KIT CONTENTS LIST**

Qty	Description	Part Number
2	Bolt, 5/16-18 Hex Hd.	7002A004-14
2	Lockwasher, 5/16	7074A019
2	Washer, Flat	7072A032
1	Bracket, Mounting	8280081

a. Using figures 2 and 3 as a guide, determine the mounting location in the bumper. Also, ensure that there is adequate clearance behind the bumper.

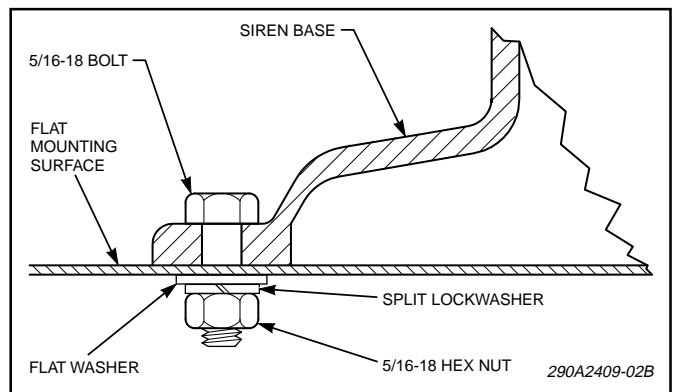

Figure 1.

**WARNING**

Avoid damage to brake lines, fuel lines, electrical wiring, and other vital parts. When drilling or cutting on ANY part of the vehicle, ensure that both sides of the surface are clear of parts that could be damaged.

- b. Cut the hole pattern in the bumper as shown in figure 2.
- c. Secure the mounting bracket to the bumper with user-supplied hardware as shown in figure 4.
- d. See figure 3. Slide the siren in the bumper from the front. Apply Loctite 471, or equivalent, to the supplied bolts. Secure the siren to the bracket using the supplied bolts, washers, and lockwashers.

4. *Brake Switch Installation.*

**CAUTION**

The brake is designed for use with a momentary type switch only. Use of any other type of switch will result in premature failure of the brake solenoid.

Install the user-supplied *momentary* switch in a location which will allow both the vehicle and the controls to be operated safely in all driving conditions.

5. *Foot Switch Installation.*

**WARNING**

When installing equipment inside air bag equipped vehicles, the installer **MUST** ensure that the equipment is installed **ONLY** in areas recommended by the vehicle manufacturer.

Failure to observe this warning will reduce the effectiveness of the air bag, damage the air bag, or potentially damage or dislodge the equipment, causing serious injury or death to you or others.

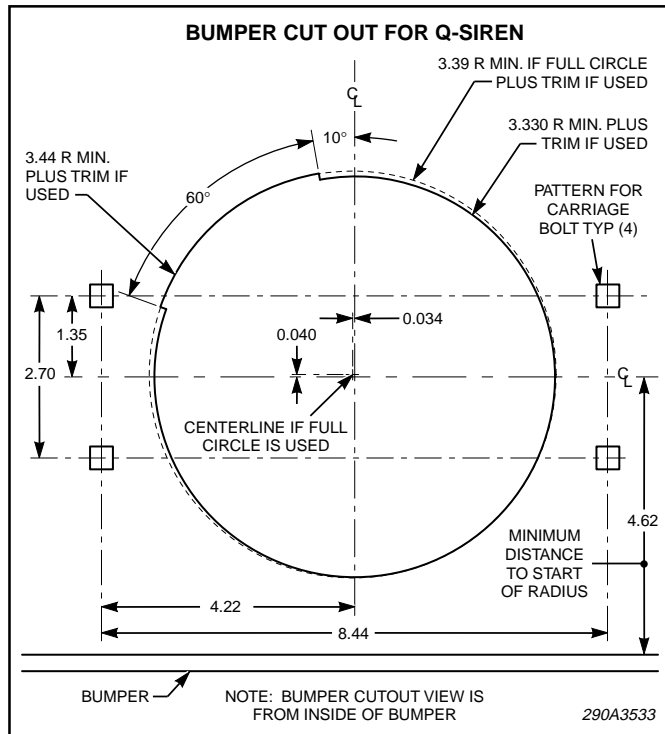

Figure 2.

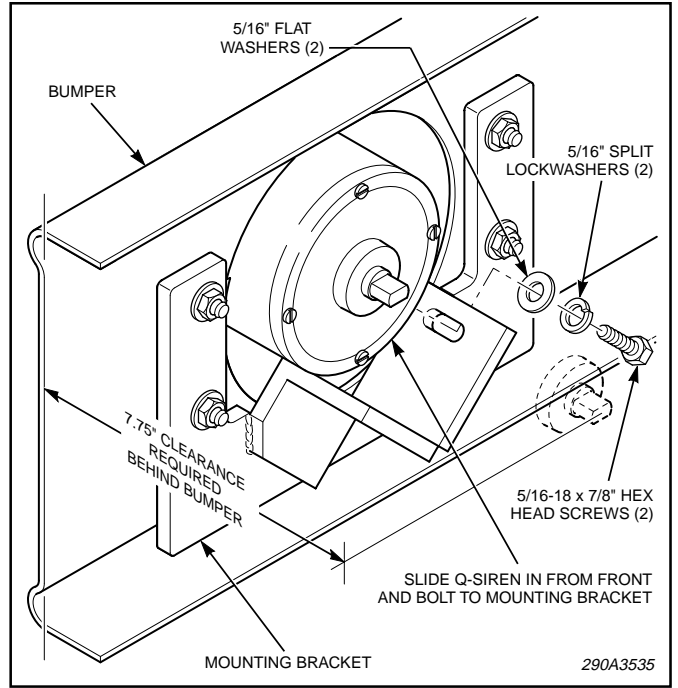

Figure 3.

Install the user-supplied foot switch (siren starting switch) on the vehicle's floor in an area which will allow both the vehicle and the controls to be operated safely in all driving conditions.

**NOTE**

The Federal Model Q2FSK, brake and foot switch kit, can be purchased separately.

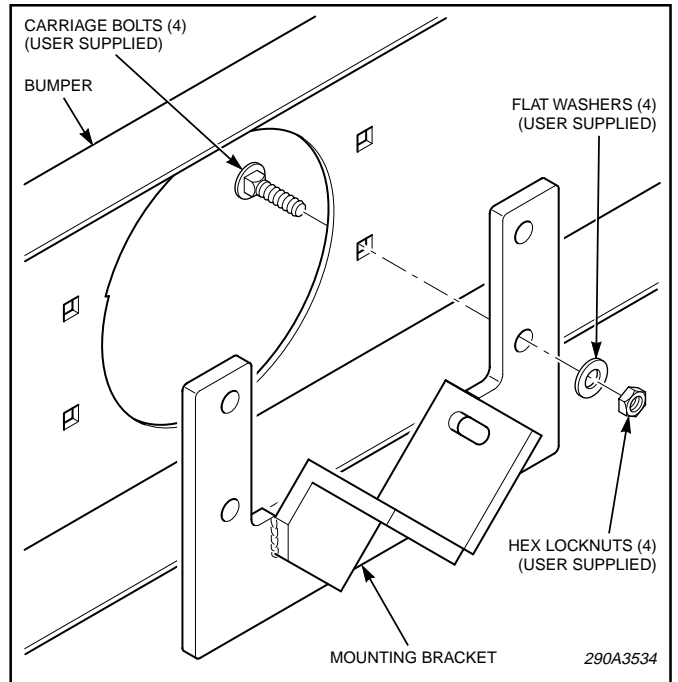

Figure 4.

## E. ELECTRICAL CONNECTIONS.

### CAUTION

The siren will not function properly without a good vehicle ground. Ensure that the paint around the mounting holes on both sides of the mounting surface has been removed and that the mounting surface provides an effective ground path.

### WARNING

If wires are shorted to the vehicle frame or each other, high current conductors can cause hazardous sparks resulting in electrical fires and molten metal.

Verify that no short circuits exist before connecting to the Positive (+) battery terminal.

DO NOT connect this system to the vehicle battery until ALL other electrical connections are made and mounting of all components is complete.

Failure to observe this WARNING will result in fire, burns and blindness.

Electrical connections should be made as shown in figure 5. Install user-supplied fuseholders and fuses (current ratings shown in figure 5) as close as practical to the battery. Insulate all exposed connections with electrical tape.

## F. TESTING.

### WARNING

All effective sirens and horns produce loud sounds (120 dB) that may cause permanent hearing loss. Always minimize your exposure to siren sound and wear hearing protection. Do not sound the siren indoors or in enclosed areas where you and others will be exposed to the sound.

Test the siren system to ensure that it is functioning properly.

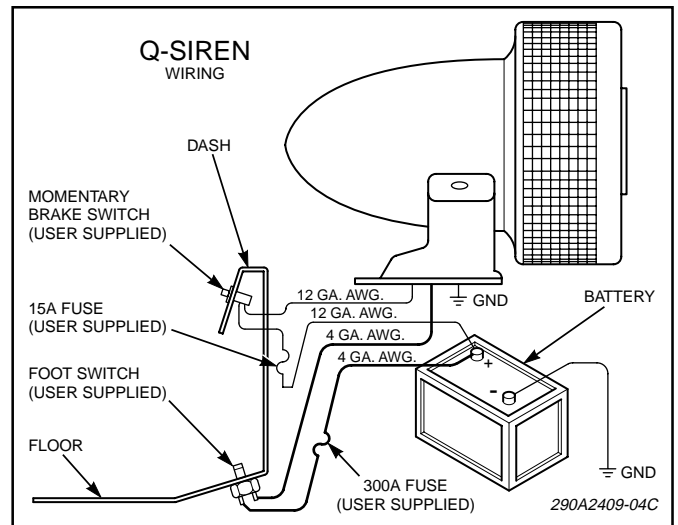

Figure 5.

## G. OPERATION.

### SAFETY MESSAGE TO OPERATORS



The lives of people depend on your safe operation of Federal products. It is important to read and follow all instructions shipped with the products. In addition, listed below are some other important safety instructions and precautions you should follow:

#### *Qualifications*

- To properly use an electronic siren and speaker(s): you must have a good understanding of general vehicle operation, a high proficiency in the use of safety warning equipment, and thorough knowledge of state and federal UNIFORM TRAFFIC CODES.

#### *Sound Hazards*

- Your hearing and the hearing of others, in or close to your emergency vehicle, could be damaged by loud sounds. This can occur from short exposures to very loud sounds, or from longer exposures to moderately loud sounds. For hearing conservation guidance, refer to federal, state, or local recommendations. OSHA Standard 1910.95 offers guidance on “Permissible Noise Exposure.”
- All effective sirens and horns produce loud sounds (120 dB) that may cause permanent hearing loss. Always minimize your exposure to siren sound, roll up your windows and wear hearing protection. Do not sound the siren indoors or in enclosed areas where you and others will be exposed to the sound. Only use the siren for emergency response situations.

#### *Sound Limitations*

- Before using the vehicle, check to see if the siren speakers are concealed from view. If the siren speaker is not in clear view on the front of the vehicle, use extra caution when operating the vehicle. A concealed siren speaker installation is less effective at warning others.
- Maximum sound output will be severely reduced if any objects are in front of the speaker. If your installation has obstructions in front of the speaker, drive even more cautiously.
- Frequently inspect the speaker to ensure that it is clear of any obstruction, such as mud or snow, which will reduce maximum sound output.

#### *Signaling Limitations*

- Be aware that the use of your visual and audible signaling devices does not give you the right to force your way through traffic. Your emergency lights, siren, and actions are REQUESTING the right-of-way.

- Although your warning system is operating properly, it may not alert everyone. People may not hear, see, or heed your warning signal. You must recognize this fact and continue driving cautiously.
- Situations may occur which obstruct your warning signal when natural or man-made objects are between your vehicle and others. This can also occur when you raise your hood or trunk lid. If these situations occur, be especially careful.

#### *Driving Limitations*

- At the start of your shift, you should ensure that the light/sound system is securely attached to the vehicle and operating properly.
- If the unique combination of emergency vehicle equipment installed in your vehicle has resulted in the siren controls being installed in a position that does not allow you to operate them by touch only, OPERATE CONTROLS ONLY WHILE YOUR VEHICLE IS STOPPED.
- If driving conditions require your full attention, you should avoid operating the siren controls while the vehicle is in motion.

#### *Continuing Education*

- File these instructions in a safe place and refer to them periodically. Give a copy of these instructions to new recruits and trainees.

Failure to follow these safety precautions may result in property damage, serious injury, or death to you, to passengers, or to others.

### CAUTION

Premature failure of brake will result if the foot switch and brake switch are depressed at the same time.

The siren is activated by depressing the foot switch. When the siren's sound has peaked, release the foot switch and allow it to coast down. Before the siren stops, depress the foot switch again. This produces a “wailing” sound which provides maximum signalling effectiveness and optimum siren life.

### CAUTION

Actuation of the brake switch for more than 30 seconds can damage the brake solenoid.

If it becomes necessary to stop the siren rapidly, depress the brake switch.

## G. SERVICE.

### SAFETY MESSAGE TO PERSONNEL SERVICING FEDERAL SIGNAL SIRENS

#### WARNING

The lives of people depend on your proper servicing of Federal products. It is important to read and follow all instructions shipped with the products. In addition, listed below are some other safety instructions and precautions you should follow:

- Read and understand all instructions in this manual before servicing the electronic siren or speaker.
- To properly service an electronic siren or speaker: you must have a good understanding of automotive electrical procedures and systems, along with proficiency in the installation and service of safety warning equipment. Always refer to the vehicle's service manuals when performing service on a vehicle.
- Electronic circuit and speaker repairs must be performed by a qualified and competent electronic technician.
- Your hearing and the hearing of others, in or close to your emergency vehicle, could be damaged by loud sounds. This can occur from short exposures to very loud sounds, or from longer exposures to moderately loud sounds. For hearing conservation guidance, refer to federal, state, or local recommendations. OSHA Standard 1910.95 offers guidance on "Permissible Noise Exposure."
- All effective sirens and horns produce loud sounds (120 dB) that may cause permanent hearing loss. Always minimize your exposure to siren sound and wear hearing protection. Do not sound the siren indoors or in enclosed areas where you and others will be exposed to the sound.
- DO NOT connect this system to the positive terminal of the battery until servicing is complete, and you have verified that there are no short circuits to ground.
- In order for the electronic siren to function properly, the ground connection must be made to the NEGATIVE battery terminal.
- After repair, test the electronic siren and speaker system to ensure that it is operating properly.
- Federal Signal siren amplifiers and speakers are designed to work together as a system. Combining a siren and speaker from different manufacturers may reduce the warning effectiveness of the siren system and may damage the components. You should verify or test your combination to make sure the system works together properly and meets both federal, state and local standards or guidelines.

Failure to follow all safety precautions and instructions may result in property damage, serious injury, or death to you or others.

For warranty service, contact your local Distributor.

The factory can and will service your equipment or assist you with technical problems that cannot be handled satisfactorily and promptly locally.

Communications and shipments should be addressed to:

Service Department  
Federal Signal Corporation  
2645 Federal Signal Drive  
University Park, IL 60466

1-800-433-9132

## H. MAINTENANCE.

#### WARNING

To prevent accidental activation of siren, disconnect the battery terminals before any maintenance operation is performed.

#### CAUTION

The use of cleaning agents such as strong detergents, solvents, petroleum products, etc. can damage the chrome plated surfaces.

Ordinary cleaning of the chrome plated parts can be accomplished by using a mild soap and water solution and a soft rag. Should fine scratches or a haze appear on the chrome parts, they can ordinarily be removed with a non-abrasive, high quality, one-step, automotive paste cleaner/wax and a soft cloth.

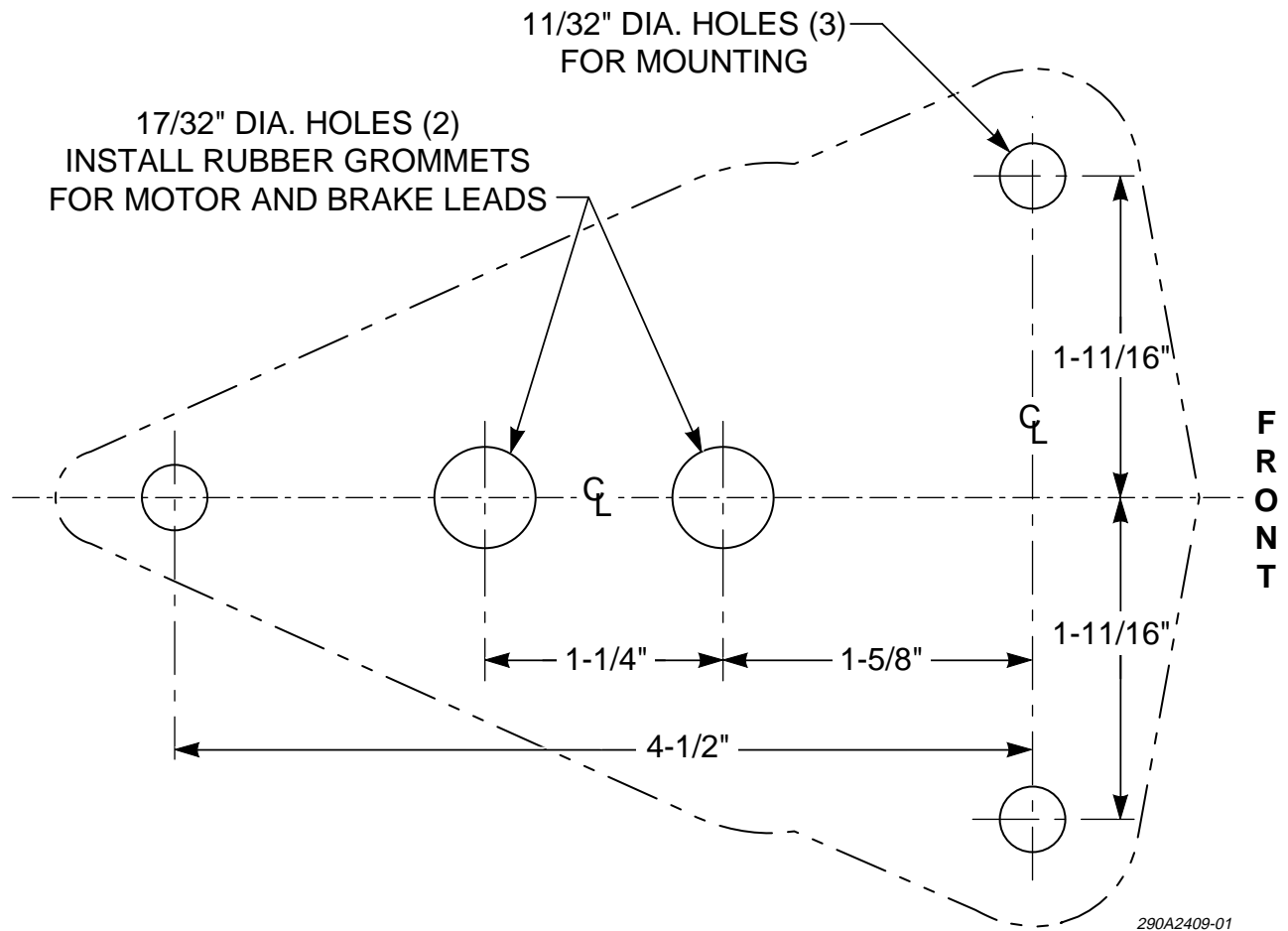

Pedestal Mounting Hole Template.

