



FEDERAL SIGNAL
Safety and Security Systems

Valor[®] Light Bar



Installation, Maintenance, and Service Manual

Limited Warranty

This product is subject to and covered by a limited warranty, a copy of which can be found at www.fedsig.com/SSG-Warranty. A copy of this limited warranty can also be obtained by written request to Federal Signal Corporation, 2645 Federal Signal Drive, University Park, IL 60484, email to info@fedsig.com or call +1 708-534-3400.

This limited warranty is in lieu of all other warranties, express or implied, contractual or statutory, including, but not limited to the warranty of merchantability, warranty of fitness for a particular purpose and any warranty against failure of its essential purpose.



FEDERAL SIGNAL Safety and Security Systems

2645 Federal Signal Drive
University Park, Illinois 60484-3167

www.fedsig.com

Customer Support

Police/Fire-EMS: 800-264-3578 • +1 708 534-3400

Work Truck: 800-824-0254 • +1 708 534-3400

Technical Support 800-433-9132 • +1 708 534-3400

All product names or trademarks are properties of their respective owners.

Contents

Safety Messages.....	5
Safety Message to Installers and Service Personnel of Warning Lights.....	5
Safety Message to Operators of Warning Light Equipment.....	8
An Overview of the Valor Light Bar	10
LED Lights, Colors, and Flash Patterns	10
Modular Connector System	10
Controller Options	10
Preparing the Valor for Installation.....	12
Unpacking the Light Bar	12
Connecting the Valor for Programming	12
Selecting External SignalMaster Control.....	14
Selecting Internal SignalMaster Control (Factory Default).....	14
Entering Program Mode.....	15
Exiting Program Mode	19
Wiring the Valor in the Vehicle	20
Planning the Electrical Installation.....	20
Connecting Power to the Light Bar	21
Installing the Serial Interface Module.....	22
Wiring the Serial Interface Module.....	24
Maintaining and Servicing the Valor.....	35
Cleaning the Light Bar Lens.....	35
Removing and Reinstalling the Light Bar Lens.....	36
Replacing a PCB.....	37
Disconnecting/Connecting Power and CAT5 at the Light Bar	38
Troubleshooting the Light Bar	41
Quick Testing the Valor with the Light Bar Test.....	42
Testing the Steady Burn LEDs (HotFoot Only)	43
Getting Technical Support and Service.....	43
Getting Repair Service.....	43
Replacement Parts.....	44

Tables

Table 1 Dimensions	11
Table 2 Light Specifications	11
Table 3 Electrical and Temperature.....	11
Table 4 SW2 DIP switch settings in the Serial Interface Module.....	15
Table 5 Control wires from the Serial Interface Module	16
Table 6 Switch settings for Intersection operation	19
Table 7 SignalMaster control wires and warning patterns	27
Table 8 Troubleshooting tips	41

Figures

Figure 1 Serial Interface Module connections for programming	13
Figure 2 Connectors and switches on the Serial Interface Module	17
Figure 3 Relay-isolating devices with large filter capacitors	23
Figure 4 Wiring block diagram	24
Figure 5 SignalMaster flash sequences.....	27
Figure 6 SignalMaster control functions wired to 12 Vdc for internal SIM control.....	28
Figure 7 SignalMaster control functions wired to ground for external SIM control.....	29
Figure 8 Typical connections with a SignalMaster controller (external control).....	30
Figure 9 Typical connections with a SW400SS Switch Module (internal control)	31
Figure 10 Typical connections with a SmartSiren Model SS2000SM controller	32
Figure 11 Typical connections with a non-SignalMaster controller.....	33
Figure 12 Typical connections with a PA640 controller	34
Figure 13 Locations of barrel nuts in light bar cover.....	36
Figure 14 Location of controller.....	37
Figure 15 Locations of watertight connectors	38
Figure 16 Secondary lock mechanism in the plug and receptacle	39

Safety Messages

For your safety, read and understand this manual thoroughly before installing, operating, and servicing the Valor light bar. The safety messages presented in this chapter and throughout the manual are reminders to exercise extreme care at all times. To download copies of the manual, go to www.fedsig.com or call the Federal Signal Service Department at 1-800-433-9132, 7 a.m. to 5 p.m., Monday through Friday (CT).

Safety Message to Installers and Service Personnel of Warning Lights

⚠ WARNING

People's lives depend on your proper installation and servicing of Federal Signal products. It is important to read and follow all instructions shipped with this product. Listed below are some other important safety instructions and precautions you should follow:

Before Installation or Service

Qualifications

- To properly install or service this equipment, you must have a good understanding of automotive mechanical and electrical procedures and systems along with proficiency in the installation and service of safety warning equipment. Always refer to the vehicle service manuals when performing equipment installations on a vehicle.

Light Hazards

- To be an effective warning device, this product produces bright light that can be hazardous to your eyesight when viewed at a close range. Do not stare directly into this lighting product at a close range or permanent damage to your eyesight may occur.
- Do not install the light system in an area that would block, impair, or blind the driver's vision. Ensure that the light system is mounted in a position that is outside of the driver's field of vision, so the driver can safely operate the vehicle.
- Federal Signal power supplies and lightheads are designed to work together as a system. Combining lightheads and a power supply from different manufacturers may reduce the warning effectiveness of the lighting system and may damage the components. You should verify or test your combination to ensure the system works together and meets federal, state, and local standards or guidelines.

Electrical Hazards

- Strobe systems present a shock hazard because they use high voltage to operate. Do not handle strobe cables, the power supply, or bulbs or remove the lens while the equipment is connected. Strobe systems can also hold their charge even after they have been turned off. After disconnecting power to the unit, wait five minutes before handling any parts of the strobe system.

- A light system is a high current system. In order for the system to function properly, a separate negative (–) connection and positive (+) connection must be made. All negative connections should be connected to the negative battery terminal and a suitable fuse should be installed on the positive battery terminal connection as close to the battery as possible. Ensure that all wires and fuses are rated correctly to handle the device and system amperage requirements.
- Never attempt to install aftermarket equipment that connects to the vehicle wiring without reviewing a vehicle wiring diagram available from the vehicle manufacturer. Ensure that your installation will not affect vehicle operation or mandated safety functions or circuits. Always check the vehicle for proper operation after installation.
- The lighting system components, especially light bulbs, strobe tubes, LEDs, and the outer housing, get hot during operation. Be sure to disconnect power to the system and allow the system to cool down before handling any components of the system.
- Halogen light bulbs and strobe tubes are pressurized and if broken, can burst and result in flying glass. Always wear gloves and eye protection when handling these components.
- Do not mount a radio antenna within 18 inches (45.7 cm) of the lighting system. Placing the antenna too close to the lighting system could cause the lighting system to malfunction or be damaged by strong radio fields. Mounting the antenna too close to the lighting system may also cause the radio noise emitted from the lighting system to interfere with the reception of the radio transmitter and reduce radio reception.
- Do not attempt to wash any unsealed electrical device while it is connected to its power source.

During Installation and Service

- DO NOT get metal shavings inside the product. Metal shavings in the product can cause the system to fail. If drilling must be done near the unit, place an ESD-approved cover over the unit. Inspect the unit after mounting to be sure there are no shavings present in or near the unit.
- To avoid a battery explosion, always disconnect the negative battery cable first and reconnect it last. Avoid causing a spark when connecting near or to the battery. The gases produced by a battery can cause a battery explosion that could result in vehicle damage and serious injury.
- DO NOT connect this system to the vehicle battery until ALL other electrical connections are made, mounting of all components is complete, and you have verified that no shorts exist. If the wiring is shorted to the vehicle body or frame, high current conductors can cause hazardous sparks resulting in electrical fires or flying molten metal.

- DO NOT install equipment or route wiring (or the plug in cord) in the deployment path of an airbag.
- If a vehicle seat is temporarily removed, verify with the vehicle manufacturer if the seat needs to be recalibrated for proper airbag deployment.
- Before mounting any components, check the manual to be sure that the component you are installing is suitable for use in that area of the vehicle. Many components are not suitable for use in the engine compartment or other extreme environmental exposure areas.
- The service life of light bulbs and strobes tubes will be shortened if the glass portion is touched during installation. Use gloves when handling these components. If the glass portion has been touched, clean the glass carefully with isopropyl alcohol.
- When drilling into a vehicle structure, be sure that both sides of the surface are clear of anything that could be damaged. Remove all burrs from drilled holes. To prevent electrical shorts, grommet all drilled holes through which wiring passes. Also, ensure that the mounting screws do not cause electrical or mechanical damage to the vehicle.
- Refer to the manual packed with the lighting system for proper electrical connections, additional precautions, and information.
- Because vehicle roof construction and driving conditions vary, do not drive a vehicle with a magnetically mounted warning light installed. The light could fly off the vehicle causing injury or damage. Repair of damage incurred because of ignoring this warning shall be the sole responsibility of the user.
- To avoid denting the roof of the vehicle, place the light bar mounting feet as close to the outer edge of the roof as possible.
- Roof damage can occur if the hook adjustment bolts are over-tightened. On Arjent and Vista light bars tighten the hook-adjustment bolts 10 ft-lb to 11 ft-lb. On all other light bars tighten the adjustment bolts 6 ft-lb to 7 ft-lb. Install keeper plates.
- Locate the light system controls so the VEHICLE and CONTROLS can be operated safely under all driving conditions.

After Installation or Service

- After installation, test the light system to ensure that it is operating properly.
- To ensure proper operation, test all vehicle functions, including horn operation, vehicle safety functions, and vehicle light systems. Ensure that the installation has not affected the vehicle operation or changed any vehicle safety function or circuit.

- Scratched or dull reflectors, mirrors, or lenses will reduce the effectiveness of the lighting system. Avoid heavy pressure and use of caustic or petroleum based products when cleaning the lighting system. Replace any optical components that may have been scratched or crazed during system installation.
- Do not attempt to activate or de-activate the light system control while driving in a hazardous situation.
- Frequently inspect the light system to ensure that it is operating properly and that it is securely attached to the vehicle.
- After installation and testing are complete, provide a copy of these instructions to instructional staff and all operating personnel.
- File these instructions in a safe place and refer to them when maintaining and/or re-installing the product.

Failure to follow these precautions may result in property damage, serious injury, or death.

Safety Message to Operators of Warning Light Equipment

⚠ WARNING

People's lives depend on your safe use of our products. Listed below are some important safety instructions and precautions you should follow:

- Do not attempt to activate or de-activate the light system control while driving in a hazardous situation.
- Although your warning system is operating properly, it may not be completely effective. People may not see or heed your warning signal. You must recognize this fact and continue driving cautiously.
- Situations may occur which obstruct your warning signal when natural and man-made objects are between your vehicle and others, such as raising your hood or trunk lid. If these situations occur, be especially careful.
- The effectiveness of an interior mounted warning light depends on the clarity, the tinting, and the angle of the glass it is being placed behind. Tinting, dirt, defects, and steeply angled glass reduce the light output of the warning light. This may reduce the effectiveness of the light as a warning signal. If your vehicle has dirty, tinted, or steeply angled glass, use extra caution when driving your vehicle or blocking the right of way with your vehicle.
- All effective sirens and horns produce loud sounds that may cause, in certain situations, permanent hearing loss. You and your passengers should consider taking appropriate safety precautions, such as wearing hearing protection.
- In order to be an effective warning device, this product produces bright light that can be hazardous to your eyesight when viewed at a close range. Do not stare directly into this lighting product at a close range or permanent damage to your eyesight may occur.

- It is important that you fully understand how to safely operate this warning system before use.
- Only operate your vehicle and its light/sound system per your department's Standard Operating Procedures.
- If a selected function does not perform properly or if any of the lamps remain illuminated when the control is off, disconnect the power connector from the control unit and contact the nearest service center.
- At the start of your shift, you should ensure that the entire warning light system and the siren system is securely attached and operating properly.
- Suction cup mounting is for temporary applications only. The unit should be removed from the window and stored securely when not in use. Temperature changes and sunlight can cause suction cups to lose holding power. Periodically check the unit to be sure the suction cups have a firm grip on the mounting surface. An improperly secured light could fall off of the vehicle causing injury and damage.
- Holding power of magnetic mounting systems is dependent upon surface finish, surface flatness, and thickness of the steel mounting surface. Therefore, to promote proper magnetic mounting:
 - Mounting surface and magnets must be kept clean, dry, and free of foreign particles that prevent good surface contact.
 - Ensure that mounting surface is flat.
 - A magnet mounting system should not be used on vehicles with vinyl tops.
 - To prevent sliding of light assembly on mounting surface, quick acceleration and hard stops should be avoided.

Failure to follow these precautions may result in property damage, serious injury, or death.

An Overview of the Valor Light Bar

The Valor Light Bar is a single-level LED light bar with ROC™ (Reliable On-Board Circuitry) and Solaris® LED technologies. ROC™ eliminates approximately 85 percent of potential failure points by incorporating a printed circuit board (PCB) in one assembly to substantially reduce the number of electrical connections. Solaris S2 LED modules use offset, complex reflector surfaces for accurate beam-shaping and the highest optical efficiency. The reflectors' overlapping, 360-degree lighting eliminates weak spots and provides off-axis warning around the light bar. The light bar is shaped to provide maximum intersection warning, the most dangerous situation in moving traffic.

LED Lights, Colors, and Flash Patterns

The light bar's internal microprocessor supplies three priority operational modes and a library of 27 flash patterns. To increase the safety of officers, pedestrians, and motorists, the light bar has standard front and rear cutoff, dimming, and intersection warning. Bright white LED takedown and alley lights that are horizontally adjustable are also available with the HotFoot™ configured option.

Multi-color heads are available with up to three different colored LEDs, eliminating the loss of primary warning colors in takedown, alley, and directional warning positions. Individual Valor lightheads can flash between red, blue, amber, or white.

Modular Connector System

The Valor Light Bar has a waterproof (IP67) external connector system for power and communication to allow removal of the light bar from the vehicle without opening the light bar or the vehicle hood. The Valor is protected against reversed polarity damage. The Valor Light Bar may be installed in any vehicle with a 12-volt negative ground electrical system.

Controller Options

Flash patterns are controlled through the light bar's CAT5 communication cable. The cable connects to the Serial Interface Module (Part Number 8583446), the Federal Signal Six-Button Serial Controller (Part Number 8623133), the Three-Button Serial Controller (Part Number 8623141), or the SmartSiren Series Platinum System or the System control head only.

With the Serial Interface Module, the Valor Light Bar can be activated by Federal Signal light bar controllers, SignalMaster directional-light controllers, or by individual low-current switch boxes.

Other advanced features of the Valor Light Bar include:

- A high degree of reliability through the use of advanced microprocessors and other integrated circuits.
- One piece seamless construction that eliminates leaking bulkhead gaskets.
- High output, long-life LEDs with no bulbs to change.

Table 1 Dimensions

Model	Length	Height	Width	Weight*
VALR44	43.7 in (111.0 cm)	1.96 in (5.0 cm)	19.8 in (50.4 cm)	39.3 lb (17.8 kg)
VALR51	51.3 in (130.3 cm)	1.96 in (5.0 cm)	19.8 in (50.4 cm)	43.2 lb (19.6 kg)

*With standard mounting feet

Table 2 Light Specifications

Lighting Option	Current Draw*	Lamp Technology	Reflector Style
LED (all heads)	1.0 A	High brightness LED	Offset, compound curve, polished reflector

*Amperage in Steady Burn Mode

Table 3 Electrical and Temperature

Model	Electrical Potential	Current Draw*	Operating Temperature
VALR44	12.8 Vdc	12.0 A 14.0 A with HotFoot	-40°F to 149°F (-40°C to 65°C)
VALR51	12.8 Vdc	14.0 A 16.0 A with HotFoot	-40°F to 149°F (-40°C to 65°C)

*Amperage for a typically loaded light bar with all lights flashing at 50 percent duty cycle

Preparing the Valor for Installation

Taking the preparatory steps in this chapter before mounting and wiring the light bar to a vehicle will help ensure that your installation is fast, easy, and error free. In addition to instructions for quick testing the light bar, this chapter has instructions for changing default settings and flash patterns with the Serial Interface Module. The number of available flash patterns vary between the Serial Interface Module and the SmartSiren Platinum System. If you are using the SmartSiren Platinum System, refer to the “Smart Siren Platinum Installation, Maintenance, and Service Manual” (Doc. No. 2562502) and to the “Smart Siren Platinum Control Pad Configuration Software Manual” (Doc. No. 2562418) programming instructions.

Unpacking the Light Bar

Carefully unpack the light bar assembly and any other products included in the shipment. Inspect them for damage that may have occurred during shipping. If a product has been damaged, do not install or operate it. Immediately file a claim with the carrier describing the damage. Carefully check all envelopes, shipping labels, and tags before removing or destroying them. If you are missing any parts, contact Customer Support at 1-800-264-3578, 7 a.m. to 5 p.m., Monday through Friday (CT).

Connecting the Valor for Programming

⚠ WARNING

HEAVY OBJECT: Use lifting aids and proper lifting techniques when removing or replacing this product. Failure to follow this warning may cause personal injury.

NOTICE

REVERSE POLARITY/MISWIRING: Reverse polarity may damage the siren amplifier. To avoid damage to the siren/amplifier, ensure that the battery voltage is the same voltage as the rating of the light and that the correct polarity is observed.

The Valor does not require any internal wiring. Two 10 AWG power conductors (red and black) and a CAT5 cable exit the light bar. The light bar’s basic light functions are communicated through the CAT5 cable, which connects to the Serial Interface Module, SmartSiren Platinum, or other Federal Signal controllers.

The electrical connections in this section enable you to perform a quick test of the light bar with the Serial Interface Module. The Serial Interface Module communicates between an installer-supplied light bar/siren controller, a SignalMaster controller, or a switch box and the light bar. To minimize the number of discrete wires to the light bar, control head functions are wired to the Module through a 3-foot-long, 24-conductor cable harness. The information is converted to a digital format and communicated through the CAT5 serial communication cable.

The numbers in the steps below refer to the wires in Figure 1. To connect the Valor to the battery and Serial Interface Module:

1. To supply power to the light bar, use a fully-charged 12-volt automotive battery with terminal lugs.
2. Place the light bar on a sturdy, flat surface.
3. Plug the CAT5 communication cable (1) from the light bar into the Serial Interface Module (J1).
4. Plug the 24-pin harness (2) into the Serial Interface Module.
5. Attach the light bar's black ground-power line (3) to the negative battery (-GND) lug.
6. Attach the light bar's red power line (4) through a 40 A Maxi™ fuse to the positive battery (+BAT) lug.
7. Attach the white wire (5) from the 24-pin harness through a 1 A fuse to the positive battery (+BAT) lug.
8. Attach the black wire and the black/white wire (6) from the 24-pin harness to the negative battery (-GND) lug.

Figure 1 Serial Interface Module connections for programming

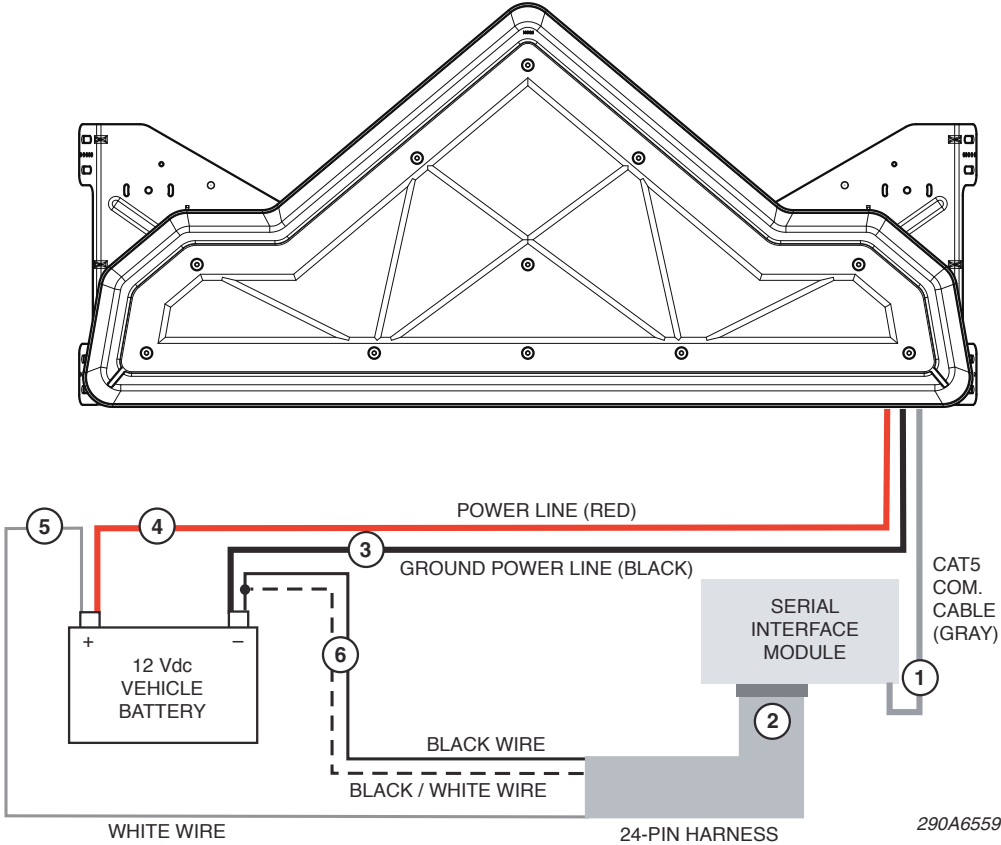

Selecting External SignalMaster Control

The Interface Module comes factory-set for the INTERNAL SignalMaster option. See “Selecting Internal SignalMaster Control (Factory Default)” on page 14. With EXTERNAL control the Interface Module drives each SignalMaster head independently via an external Federal Signal SignalMaster controller or the SS2000SM Series Siren. Either device provides an independent ground signal to illuminate each head.

To select External SignalMaster control:

1. Unplug the 24-pin harness from the Serial Interface Module.
2. Move Switch 4 on SW2 to the up (OFF) position (Table 4).
3. Plug the 24-pin harness into the Serial Interface Module.

Selecting Internal SignalMaster Control (Factory Default)

The Interface Module SignalMaster control leads are defined in Table 5 on page 16. The SignalMaster can be configured for internal operation. Power (+BAT) applied to the specified control lead activates the light bar’s internal SignalMaster controller. The Internal SignalMaster setting controls the flash pattern, rather than driving each SignalMaster head.

To select Internal SignalMaster control:

1. Unplug the 24-pin harness from the Serial Interface Module.
2. Move Switch 4 on SW2 to the down (ON) position.
3. Plug the 24-pin harness into the Serial Interface Module.

Table 4 SW2 DIP switch settings in the Serial Interface Module

SW2 Switch Number	Switch Setting		Function
	Up (OFF)	Down (ON)	
1	X		Front/Rear LEDs cut off (turn off) when 12 Vdc is applied their control wires (Table 5 on page 16)
1		X	Front/Rear LEDs enable (turn on) when 12 Vdc is applied to their control wires
2	X		Keep in OFF position.
3	X		Intersection when 12 Vdc is applied to blue/black wire. Light Bar Test when 12 Vdc is applied to black/white/red wire.
		X	Left Scene Light turns on when 12 Vdc is applied to blue/black wire. Right Scene Light turns on when 12 Vdc is applied to black/white/red wire. Intersection and Light Bar Test are unavailable. This function applies only to light bars with SpectraLux technology (Valor and Vision SLR).
4		X	SignalMaster, Internal controller
4	X		SignalMaster, External controller
5	X		Cycle forward through the selection of flash patterns
5		X	Cycle backward through the selection of flash patterns
6	X		Operation Mode
6		X	Program Mode
7	Switch for Intersection operational settings (Table 6 on page 19).		
8	Switch for Intersection operational settings (Table 6)		

Entering Program Mode

To switch the module from Operation Mode to Program Mode:

1. Unplug the 24-pin harness from the Serial Interface Module.
2. On the Serial Interface Module, move Switch 6 on SW2 to the down (ON) position.
3. Plug the 24-pin harness into the Serial Interface Module.

Table 5 Control wires from the Serial Interface Module

Light Bar Controls	Wire Color	Description
Mode 1	Blue	Lowest priority
Mode 2	Blue/White	Overrides Mode 1.
Mode 3	Black/Red	Overrides Modes 1 and 2.
Steady Burn (HotFoot only)	Red/White	One or more LEDs steadily burn when 12 Vdc is applied to the control wire for a Mode and the control wire for Steady Burn.
Front Cutoff	Green/White	Turns off the front of the light bar.
Front Enable		Turns on the front of the light bar.
Rear Cutoff	Orange/Black	Turns off the rear of the light bar.
Rear Enable		Turns on the rear of the light bar.
Low Power	White/Black/Red	Dims the lights approximately 50 percent to prevent blinding approaching drivers. Low Power is only available in Modes 1 and 2 and is disabled when switched to another flash pattern, including Mode 3 and Intersection.
Flash Takedown/Alley	Red/Black	Flashes the alley and takedown lights in Modes 1, 2, or 3.
Left Alley	Green/Black	Turns on left alley lights. Overrides the Flash Takedown/Alley lights.
Right Alley	Orange/Red	Turns on right alley lights. Overrides the Flash Takedown/Alley lights.
Takedown	White/Black	Provides white light to the front. Overrides Flash Takedown/Alley lights and front cutoff.
Intersection (SW2 Switch 3 in the up position)	Blue/Black	Typically a high activity pattern. Overrides all three priority modes. Scene Light, Left is unavailable.
Scene Light, Left (SW2 Switch 3 in the down position)		Applying 12 Vdc to the Scene Light, Left wire turns on the left half of the light bar (only for Valor and Valor). Intersection is unavailable.
Light Bar Test Pattern (SW2 Switch 3 in the up position)	Black/White/Red	Flashes the LEDs sequentially and then flashes the takedown and alley lights. Scene Light, Right is unavailable.
Scene Light, Right (SW2 Switch 3 in the down position)		Applying 12 Vdc to the Scene Light, Right wire turns on right half of the light bar. Light Bar Test Pattern is unavailable.

SW2 DIP Switch Settings in the Serial Interface Module

For the location of SW2, see Figure 2. Table 4 on page 15 lists the DIP switch settings in the Serial Interface Module for programming flash patterns.

Figure 2 Connectors and switches on the Serial Interface Module

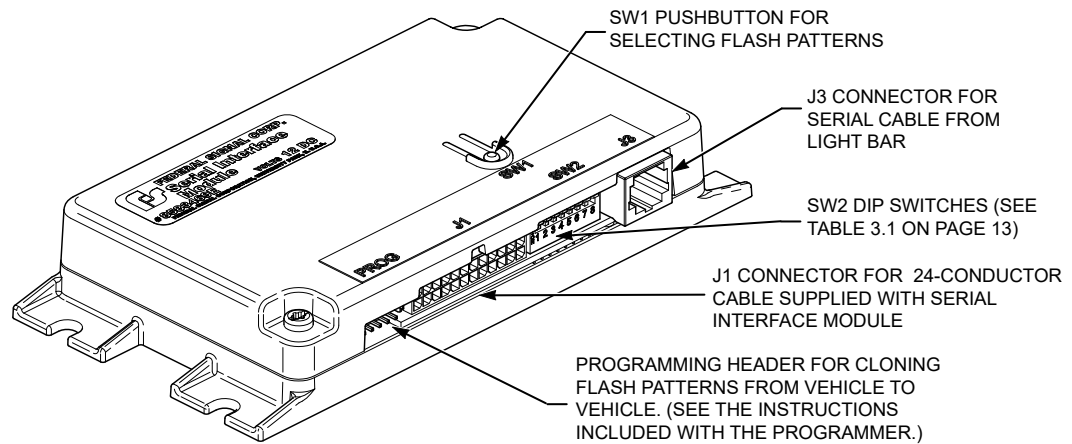

290A7702

Selecting a Flash Pattern for Modes 3, 2, 1, and Intersection

The three modes operate with Mode 3 having the highest priority: Mode 3 overrides Mode 2, and Mode 2 overrides Mode 1. When the light bar operates in one of these modes, the SignalMaster modules keep sequence with the flash pattern.

You can change default Mode flash patterns by programming each mode with one of patterns in the light bar's library. A typical setup would be:

- **Mode 1:** Rear LEDs
- **Mode 2:** Front/Rear LEDs
- **Mode 3:** Siren (SmartSiren® or Federal Signal compatible), Front/Rear LEDs, and Flash Takedown/Alley LEDs on the main bar
- **Modes 1 and 2:** Front/Rear Cutoff

NOTE: If the light bar needs to be programmed after you connect a progressive slide switch, the programming sequence must be Mode 3, Mode 2, Mode 1, Intersection.

When you press and release the SW-1 pushbutton on the Serial Interface Module to select a pattern, the light bar briefly turns off and then displays the next pattern. To cycle backwards to a previous pattern, move Switch 5 to ON (up position) on SW2.

Mode 3

1. Apply 12 Vdc (+BAT) to the Mode 3 control wire (black/red) from the Serial Interface Module to display the assigned pattern.
2. On the Serial Interface Module, press and release the SW-1 pushbutton until the pattern you want appears on the light bar.

3. Remove 12 Vdc from the Mode 3 control wire.

Mode 2

1. Apply 12 Vdc (+BAT) to the Mode 2 control wire (blue/white) from the Serial Interface Module to display the assigned pattern.
2. On the Serial Interface Module, press and release the SW-1 pushbutton until the pattern you want appears on the light bar.
3. Remove 12 Vdc from the Mode 2 control wire.

Mode 1

1. Apply 12 Vdc (+BAT) to the Mode 1 control wire (blue) from the Serial Interface Module to display the assigned pattern.
2. On the Serial Interface Module, press and release the SW-1 pushbutton until the pattern you want appears on the light bar.
3. Remove 12 Vdc from the Mode 1 control wire.

Intersection

This procedure only programs the Intersection pattern. It does not assign the pattern to a Mode. The Intersection flash pattern overrides all three priority modes when activated. To select a new pattern, you must apply 12 Vdc to the control wire for either Mode 1, 2, or 3 (Table 5 on page 16) and the blue/black control wire for Intersection. SW2 Switch 3 in the Serial Interface Module must be in the up position for this function.

NOTE: With the flexibility of the SmartSiren Platinum System, both the Intersection and the Scene Light, Left option are available in Valor and Vision SLR light bars without the need to choose one or the other.

1. Apply 12 Vdc (+BAT) to a control wire for either Mode 1, 2, or 3, and the control wire for Intersection from the Serial Interface Module.
2. On the Serial Interface Module, press and release the SW-1 pushbutton until the pattern you want appears on the light bar.
3. Remove 12 Vdc from the Mode and Intersection control wires.

Intersection Operational Settings

Select one of three options to turn on the Intersection pattern:

- HIGH with +BAT power maintained (default): the light bar displays the Intersection pattern until power is removed.
- TAP II (push-on/push-off): The Intersection flash pattern is turned on and off by pressing a momentary contact switch, such as a horn button. Momentary 12 Vdc turns on the pattern, a second momentary 12 Vdc signal turns it off.
- 8-SECOND TIMEOUT activated by +BAT: momentary 12 Vdc turns on the Intersection flash pattern for eight seconds.

To change from HIGH to TAP II or 8-SECOND TIMEOUT.

1. Unplug the 24-pin harness from the Serial Interface Module.
2. See Table 6. On the Serial Interface Module, set Switch 7 and Switch 8 on SW2 to select a method of operation. Each setting is independent of the other.
3. Plug the 24-pin harness into the Serial Interface Module.

Table 6 Switch settings for Intersection operation

Operational Settings	SW2	
	SW7	SW8
High (+BAT maintained)	OFF (up)	OFF (up)
Tap II (+BAT, push on/push off)	ON (down)	OFF (up)
8-Second Timeout (activated by +BAT)	OFF (up)	ON (down)

Front/Rear Cutoff or Enable

The operational setting for Front/Rear Cutoff or Enable must be programmed after Mode and Intersection. The default setting is for Cutoff in which the Front or Rear LEDs turn off when 12 Vdc (+BAT) is applied to their control wires. In contrast, Enable turns on these LED modules when +BAT is applied to their control wires. Both the front and rear LEDs share the same operational setting and are not independent.

To program this feature:

1. Unplug the 24-pin harness from the Serial Interface Module.
2. On the Serial Interface Module, move Switch 1 on SW2 to:
 - the down (on) position for Front/Rear Enable.
 - the up (off) position for Front/Rear Cutoff.
3. Plug the 24-pin harness into the Serial Interface Module.

NOTE: When set to Enable, 12 Vdc must be applied to a Mode control wire and the Front and/or Rear Enable control wire for the light bar to operate.

In a typical installation, if you want only the Rear LED modules to flash in Mode 1, set the operation for Enable. Connect the green/white and blue/white control wires to the Mode 2 connection and the orange/black and blue control wires to the Mode 1 connection.

Exiting Program Mode

When you are finished programming patterns, switch the Serial Interface Module from Operation Mode to Program Mode.

1. Unplug the 24-pin harness from the Serial Interface Module.
2. On the Serial Interface Module, move SW2 Switch 6 to the up (OFF) position.
3. Plug the 24-pin harness into the Serial Interface Module.

Wiring the Valor in the Vehicle

Before proceeding, ensure that the light bar has been installed on the vehicle roof in accordance with the instructions included with the mounting kit. Depending on the type of vehicle and mounting system feature, there are two options available for installing the light bar to the roof of the vehicle: hook-on mounting or permanent mounting.

⚠ WARNING

INSTALLATION PRECAUTIONS: *The warning system and/or two-way radio system may operate improperly if a two-way radio antenna is installed on or within 18 inches of the light bar. Before permanently installing the light bar or a two-way radio antenna, test the warning system and two-way radio system. Some installations may require the relocation of the two-way radio antenna to the trunk or fender. DO NOT drill holes in the light bar or install auxiliary devices on the light bar, or the warning system may fail.*

Planning the Electrical Installation

The light bar is completely wired at the factory and does not require any additional internal wiring. All the conductors necessary for control of any and all basic and optional functions are contained in the CAT5 cable. The basic light functions of the Valor must be controlled by a installer-supplied control head.

To prevent damage to the light bar and vehicle and ensure that all equipment operates properly, carefully plan where to mount and wire the light bar and controlling equipment:

1. Verify that the light bar and mounting hardware fit the vehicle.
2. Determine where to mount the light bar on the vehicle.

⚠ WARNING

LOCATING OPERATOR CONTROLS: *The controls for the light system must be located so that the VEHICLE and CONTROLS can be operated safely under all driving conditions.*

⚠ WARNING

UNIT REQUIRES SHELTER FROM WEATHER—*The Serial Interface Module is NOT waterproof. It must be mounted in a location that is sheltered from rain, snow, standing water, etc.*

3. Determine where to mount the controlling equipment:
 - Trunk or remote location
 - Console

⚠ WARNING

AIRBAG DEPLOYMENT: Do not install equipment or route wiring in the deployment path of an airbag. Failure to observe this warning will reduce the effectiveness of the airbag or potentially dislodge the equipment, causing serious injury or death.

4. Decide where to route wiring around airbag areas.

⚠ WARNING

EXPLOSION HAZARD: To avoid a battery explosion, always disconnect the negative battery cable first and reconnect it last. Avoid causing a spark when connecting near or to the battery. The gases produced by a battery can cause a battery explosion that could result in vehicle damage and serious injury.

5. Decide where to route the light bar's power and ground wires.

⚠ WARNING

SEAT REMOVAL PRECAUTION: If a vehicle seat is temporarily removed, verify with the vehicle manufacturer if the seat needs to be recalibrated for proper airbag deployment.

6. To make wiring easier, remove the seats, spare tire, and pull down the headliner where needed.
7. Separate all electronic equipment wiring from two-way radio equipment wiring.
8. To avoid interference, keep two-way radio antennas a minimum of 18 in (45.7 cm) away from warning equipment.
9. Whenever possible, run full wire lengths. DO NOT splice the wires.
10. Do not coil excess wire. Leave a drain loop for servicing.
11. After drilling holes for wires, deburr them, smooth sharp edges, and insert grommets to protect the wires from chafing.
12. When you frame-ground the equipment, use the manufacturer-supplied ground locations in the vehicle.

IMPORTANT: After the installation, frequently inspect the light bar and mounting feet to ensure that all fasteners and brackets are tight.

Connecting Power to the Light Bar

NOTE: Plan the location of the wire-routing hole in the vehicle roof so that the power and communication cables do not have tight bends and have some slack to allow disconnection on removal.

⚠ WARNING

EXPLOSION HAZARD: To avoid a battery explosion, always disconnect the negative battery cable first and reconnect it last. Avoid causing a spark when connecting near or to the battery. The gases produced by a battery can cause a battery explosion that could result in vehicle damage and serious injury.

⚠ WARNING

REVERSE POLARITY / MISWIRING: Reverse polarity or incorrect voltage may damage the light. To avoid damage to the light, ensure that the battery voltage is the same as the voltage rating of the light and that the correct polarity is observed. If you are connecting to a cigarette lighter plug or 12 V outlet, connect the positive wire to the center terminal and connect the negative wire to the outer terminal.

1. Ensure that the lines are adequately fused as shown in the wiring schematics in Chapter 5.
2. From the light bar, route the CAT5 control cable into the vehicle cab or trunk near the eventual location of the Serial Interface Module. An input cable is also provided with the Interface Module.
3. Route and connect the black lead from the light bar to the vehicle battery's ground (-GND) terminal.
4. Route and connect the red lead from the light bar through a 40 A Maxi™ fuse at the source, which is the positive battery terminal (+BAT).

Installing the Serial Interface Module

⚠ WARNING

UNIT REQUIRES VENTILATION: The Serial Interface Module needs to radiate heat. Do not install it in an area where it cannot dissipate heat into the air. Do not mount it near a heater duct.

⚠ WARNING

UNIT REQUIRES SHELTER FROM WEATHER: The Serial Interface Module is NOT waterproof. It must be mounted in a location that is sheltered from rain, snow, standing water, etc.

IMPORTANT: The Serial Interface Module must be installed within 36 in (91 cm) of the light bar controller.

To mount the Serial Interface Module and make the power connections:

1. Use the Serial Interface Module as a template and scribe four drill-position marks at the selected mounting location. Mounting centers are 2.00 in x 5.95 in (5.08 cm x 15.11 cm).

⚠ WARNING

DO NOT DRILL INTO SERIAL INTERFACE MODULE: DO NOT drill holes into ANY part of the Serial Interface Module. Damage to the unit, serious injury, or death may result.

⚠ WARNING

DRILLING PRECAUTIONS: When drilling holes, check the area you are drilling into to ensure that you do not damage vehicle components while drilling. All drilled holes should be deburred, and all sharp edges should be smoothed. All wire routings going through drilled holes should be protected by a grommet or convolute/split loom tubing.

2. Drill four mounting holes at the drill-position marks, sized for the recommended user-supplied #8 mounting hardware.
3. Secure the Serial Interface Module to the mounting surface with installer-supplied #8 hardware.
4. Install the CAT5 serial cable from the light bar to the J3 output jack of the Serial Interface Module.
5. Install the three-foot-long, 24-conductor cable from the light bar to the J1 input connector of the Serial Interface Module.

NOTE: Powering multiple devices with a common control wire may cause one or more devices to briefly remain functional after signal power is removed. For example, due to the high input filter capacitance, a strobe supply can briefly supply the current required to signal a light bar function to remain on. If necessary, use a relay to isolate devices with large filter capacitors (Figure 3). All components/wires are user-supplied.

⚠ WARNING

SHOCK HAZARD: Strobe and HID light systems generate high voltages. Disconnect power from the system and wait at least 5 minutes before opening the unit. Do not apply power to the unit while the unit is open. Failure to follow this warning could result in serious injury or death.

Figure 3 Relay-isolating devices with large filter capacitors

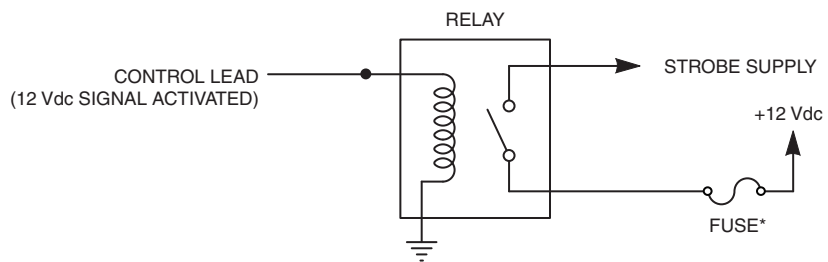

290A6562

*FUSE AMPERAGE DEPENDS ON AMPERAGE OF DEVICES

Wiring the Serial Interface Module

NOTICE

FUSE ELECTRICAL SOURCES: Always fuse current/voltage sources with a fuse connected near the power source. Ensure that the fuse is properly rated to protect the electrical load, the wiring, and the connectors used in the circuit. Failure to follow this notice could result in vehicle or equipment damage.

This section is an overview of default settings that are activated when connecting LED and Mode control wires to 12 Vdc (+BAT). The basic light functions of the light bar must be controlled by an installer-supplied control head. Programming is covered in “Selecting a Flash Pattern for Modes 3, 2, 1, and Intersection” on page 17.

For a description of the control wires from the Serial Interface Module, see Table 5 on page 16. For typical installations with common controllers and switch boxes, see the wiring schematics starting on page 28.

To wire the controller’s functions to the Serial Interface Module’s 24-pin cable harness, see Table 7 on page 27. If additional wire is necessary for the harness (except ground), 22 AWG wire is adequate. The ground wires must be extended with 16 AWG or thicker wire

Figure 4 Wiring block diagram

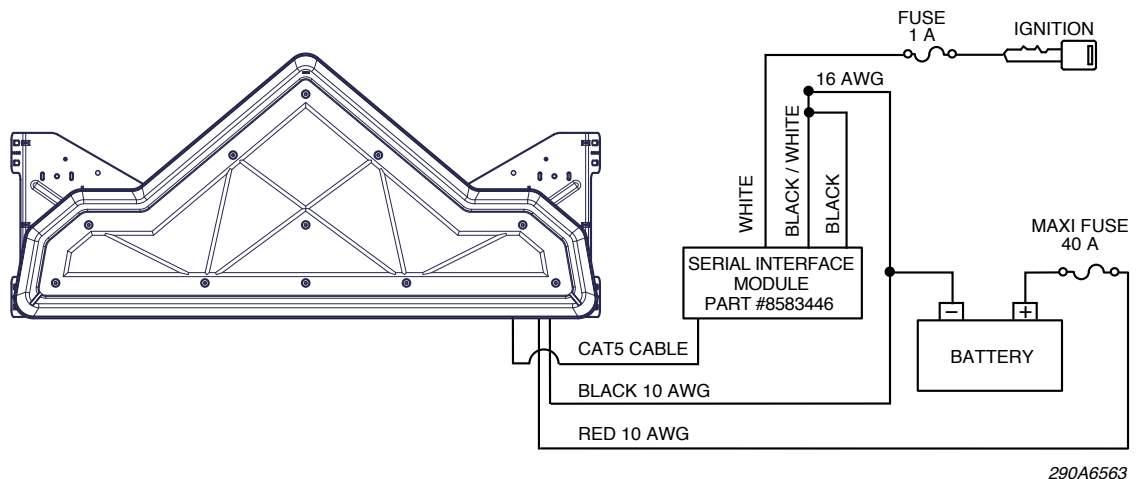

290A6563

Priority Modes 1, 2, and 3

To activate a priority mode, apply 12 Vdc (+BAT) to a mode control wire. Mode 3 (black/red) overrides Mode 2 (blue/white), and Mode 2 overrides Mode 1 (blue). You can program one of the flash patterns in the light bar to each Mode input.

Steady Burn

When the light bar is equipped with one or more Steady Burn LED modules, applying 12 Vdc (+BAT) to the control wire (red/white) for Steady Burn turns on the LEDs when any Mode input is selected.

Front Cutoff

When 12 Vdc (+BAT) is applied to the Front Cutoff control wire (green/white), the selected Mode operation is deactivated to the front of the light bar. Only the rear LEDs function. Additionally, with Flash Takedown/Alley (red/black) active, only the alley lights turn on.

Rear Cut-Off

When 12 Vdc (+BAT) is applied to the Rear Cutoff control wire (orange/black), the selected Mode operation is deactivated to the rear of the light bar. Only the front LEDs flash.

NOTE: The operational settings for Front Cutoff and Rear Cutoff are not independent. The default setting is for 12 Vdc (+BAT) to be applied for the light bar's front and rear lighthoods to turn them off (Cutoff). To change the default setting to turn on these LEDs when 12 Vdc is applied (Enable), see "Front/Rear Cutoff or Enable" on page 19.

Intersection

When 12 Vdc (+BAT) is applied to the Intersection control wire (blue/black) and a Mode control wire, it turns on the Intersection pattern. When 12 Vdc is removed, the light bar returns to its previous state. SW2 Switch 3 must be in the up (ON) position in the Serial Interface Module.

NOTE: With the flexibility of the SmartSiren Platinum System, both the Intersection and the Scene Light, Left option are available in Valor and Valor light bars without the need to choose one or the other. (See Scene Light, Left, Right below.)

Flash Takedown/Alley

When 12 Vdc (+BAT) is applied to the Flash Takedown/Alley control wire (red/black) and a MODE control wire, the takedown and alley lights flash.

Left and Right Alley Lights

When 12 Vdc (+BAT) is applied to the Left (green/black) or Right Alley control wire (orange/red), the appropriate alley LEDs turn on. The left and right alley lights override the flash/takedown alley lights.

Takedown Lights

When 12 Vdc (+BAT) is applied to the Takedown control wire (white/black), the takedown LEDs turn on. Takedown overrides Flash Takedown/Alley and Front Cutoff.

Scene Light, Left and Scene Light, Right

This function applies only to light bars with Spectralux Technology (Valor and Vision SLR). To use this function with the Serial Interface Module, place SW2 Switch 3 in the Module in the down position (ON). When 12 Vdc is applied to the Scene Light, Left control wire (blue/black), the left half of the light bar lights up. When 12 Vdc is applied to the Scene Light, Right wire (black/white/red), the right half of the light bar lights up. Intersection and Light Bar Test are unavailable with these options.

Low Power

NOTE: Low power mode is disabled when the light bar is in MODE 3 or displaying the Intersection flash pattern.

⚠ WARNING

USE THE DIMMING/LOW POWER FUNCTION PROPERLY: Enabling the Low Power function in the light bar may cause the light output to fall below certain light output standards and guidelines for emergency warning lights. Use extreme caution when using this function. Ensure that the ambient light conditions are low enough that you are seen and that the reduction of glare from the light bar is safer than full light output in the situation. Failure to heed this warning may result in serious injury or death to you or others in your vicinity.

When 12 Vdc (+BAT) is applied to the Low Power control wire, the LEDs are dimmed to approximately 50 percent of their full brightness. Low Power is only functional in MODE 1 or MODE 2. Low Power is disabled when switching to another flash pattern, including Intersection. (SW2 Switch 3 in the Serial Interface Module must be in the up position for this function.) To use Low Power again, disconnect 12 Vdc from the Low Power control wire and reapply 12 Vdc to the Low Power control wire after a change in flash pattern occurs.

Ignition

Connect the white wire from the supplied J1 cable harness on the Interface Module to a 1A fuse. Connect the fuse end as close as possible to switched ignition power. Power should also be present in the cranking position.

Connect the black and black/white wire from the 24-pin cable harness on J1 from the Serial Interface Module to battery ground (–GND). Use 16 AWG wire to extend the cable length.

Internal SignalMaster (Factory Default)

NOTE: If the SignalMaster is not activated by a control head or an external controller, the SignalMaster LED heads flash with the selected priority mode (Mode 1, 2, or 3) of operation.

The Serial Interface Module factory-set for the Internal SignalMaster option. Internal operation uses the light bar's built-in SignalMaster controller to generate directional warning patterns. With internal operation, an external SignalMaster controller is not needed. A standard low-current switch box can activate the light bar's internal SignalMaster controller.

External SignalMaster

External operation uses the Serial Interface Module to drive each SignalMaster directional warning head independently through an external Federal Signal SignalMaster controller or SS2000SM series siren. Either device provides an

independent ground signal to turn on each head (Figure 7).

For the switch setting in the Serial Interface Module, see “Selecting External SignalMaster Control” on page 14. To activate the light bar’s internal SignalMaster controller, apply 12 Vdc (+BAT) to the SignalMaster control wires (Table 7 and Figure 5).

Table 7 SignalMaster control wires and warning patterns

Warning Pattern	Control Wires	Description
LEFT	Red	Rear LEDs flash from right to left
CENTER	Green	Rear LEDs flash from center out to both sides
RIGHT	Green/Black/White	Rear LEDs flash from left to right
WARN 1	Orange/Green	Outer LEDs alternate
WARN 2	Orange	Two outer LEDs alternate
WARN 3	Blue/Red	Outer LEDs and two inner LEDs alternate
WARN 4	Red/Green	Outer LEDs and two inner LEDs flash, then the LEDs between the inner and outer LEDs
FAST	White/Red	Operates the selected pattern 50 percent faster

Figure 5 SignalMaster flash sequences

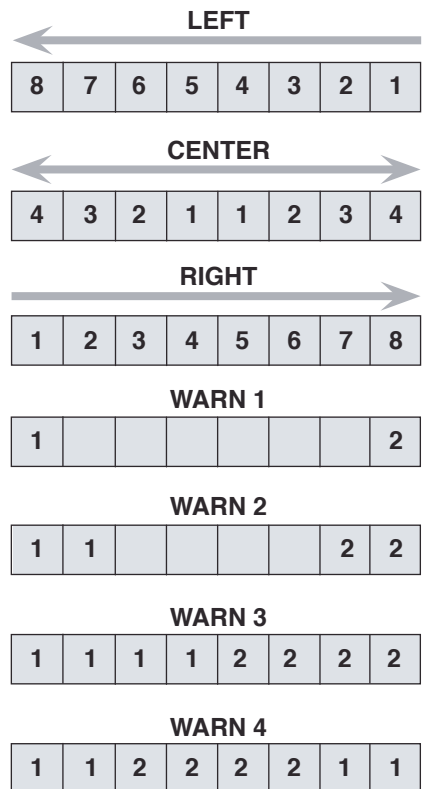

290A6578D

Figure 6 SignalMaster control functions wired to 12 Vdc for internal Serial Interface Module control

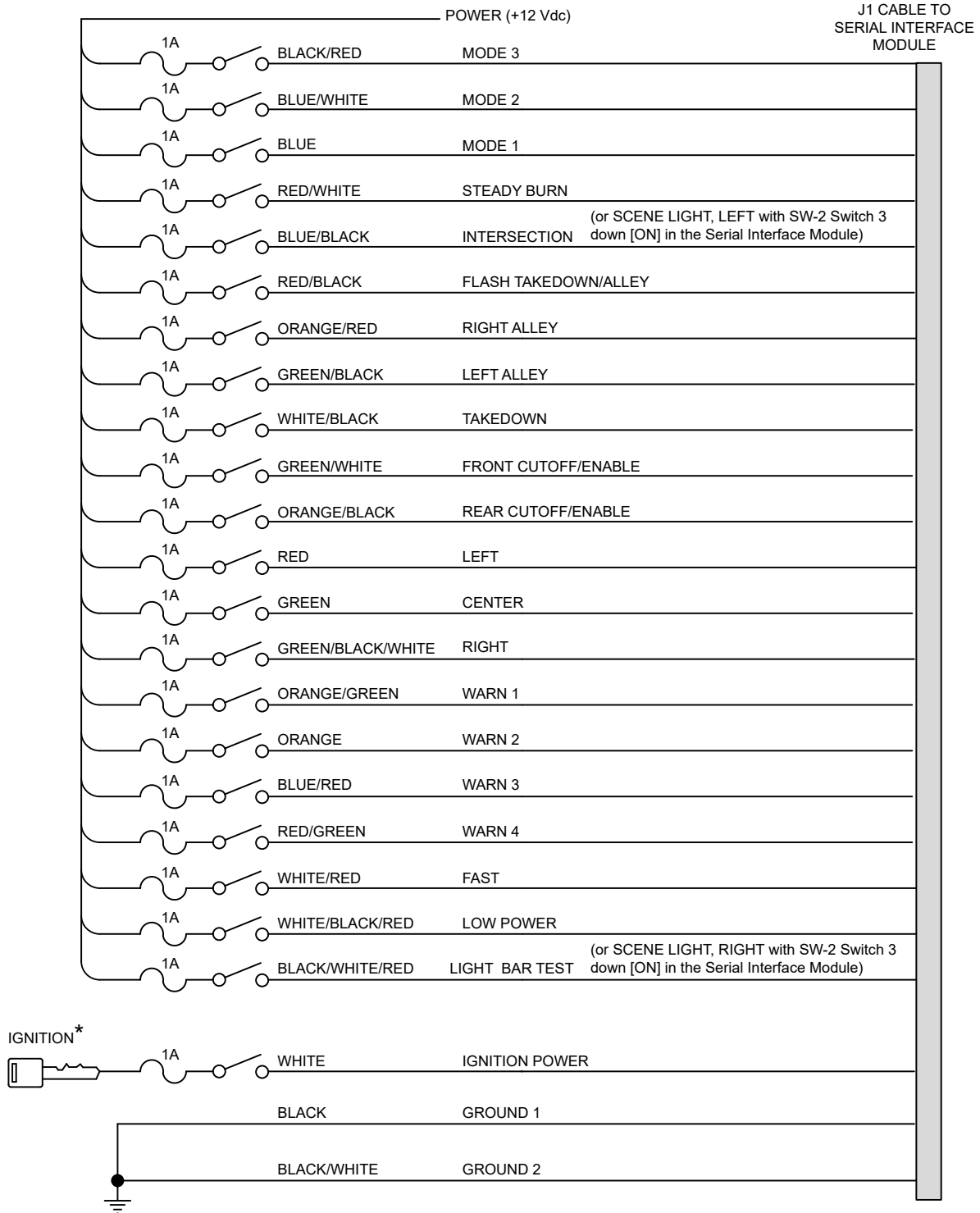

* IGNITION POWER INCLUDES POWER IN THE CRANKING POSITION

290A5981D

Figure 7 SignalMaster control functions wired to ground for external Serial Interface Module control

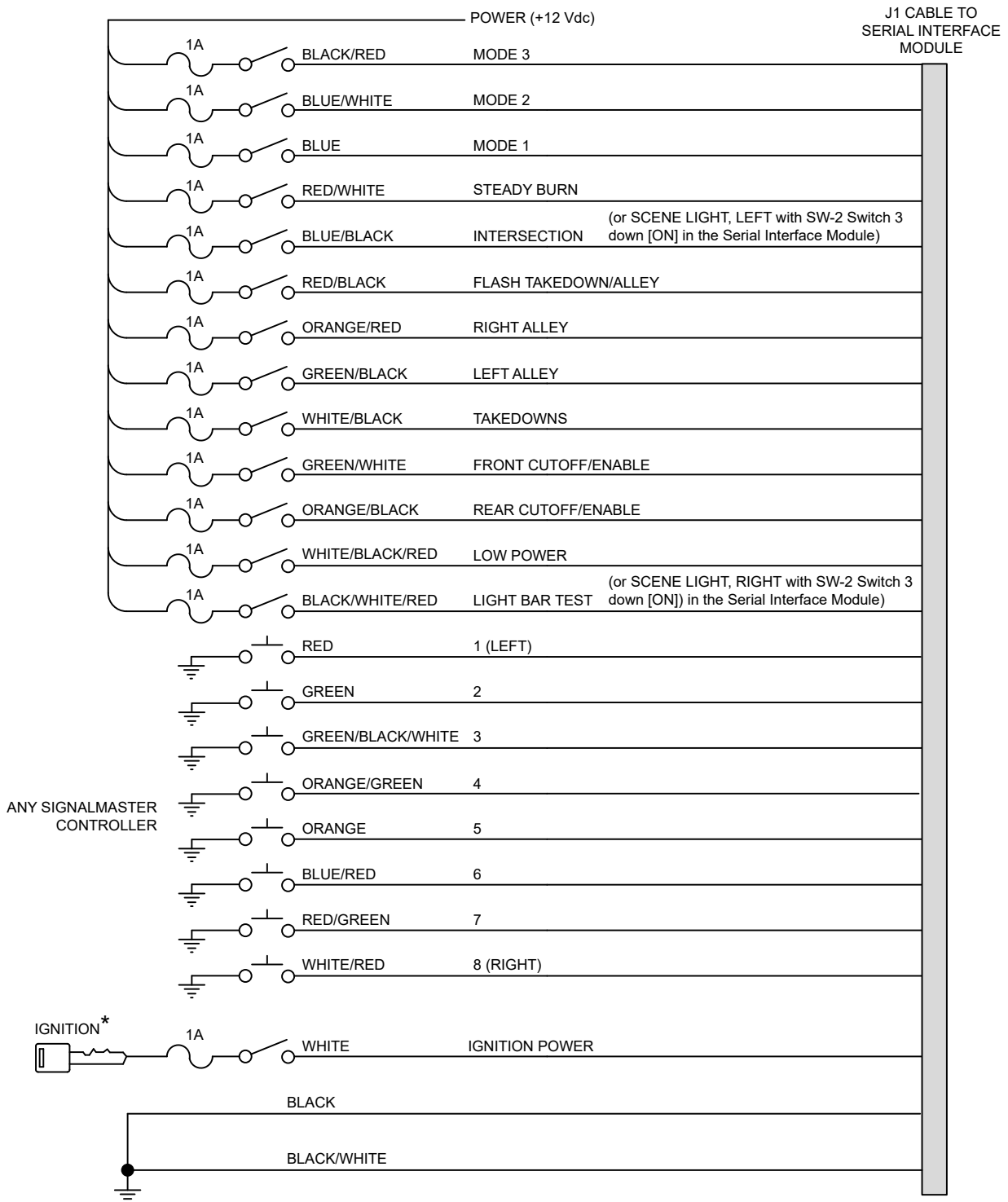

* IGNITION POWER INCLUDES POWER IN THE CRANKING POSITION

290A5980D

Figure 8 Typical connections with a SignalMaster controller (external control)

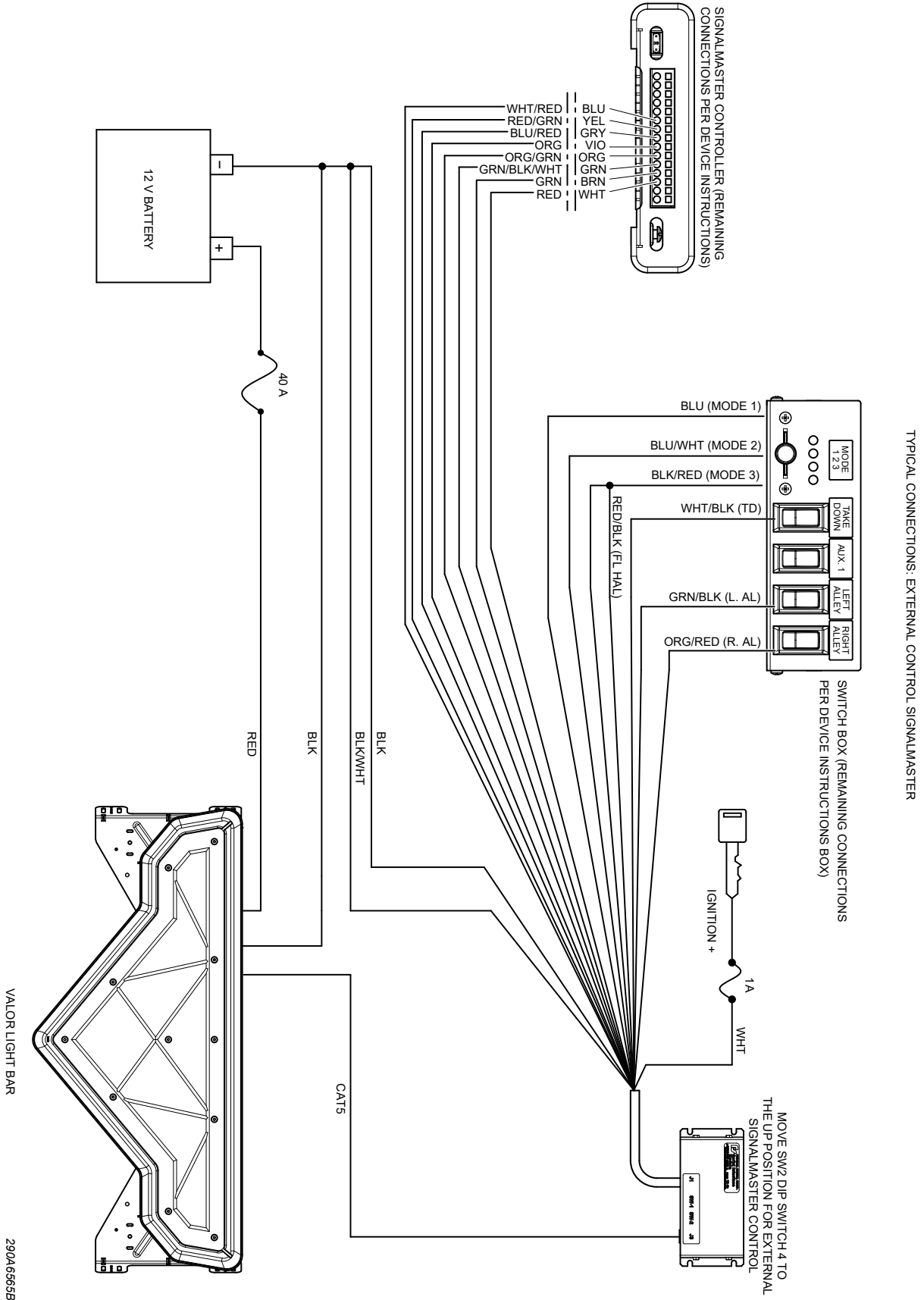

290A6565B

Figure 9 Typical connections with a SW400SS Switch Module (internal control)

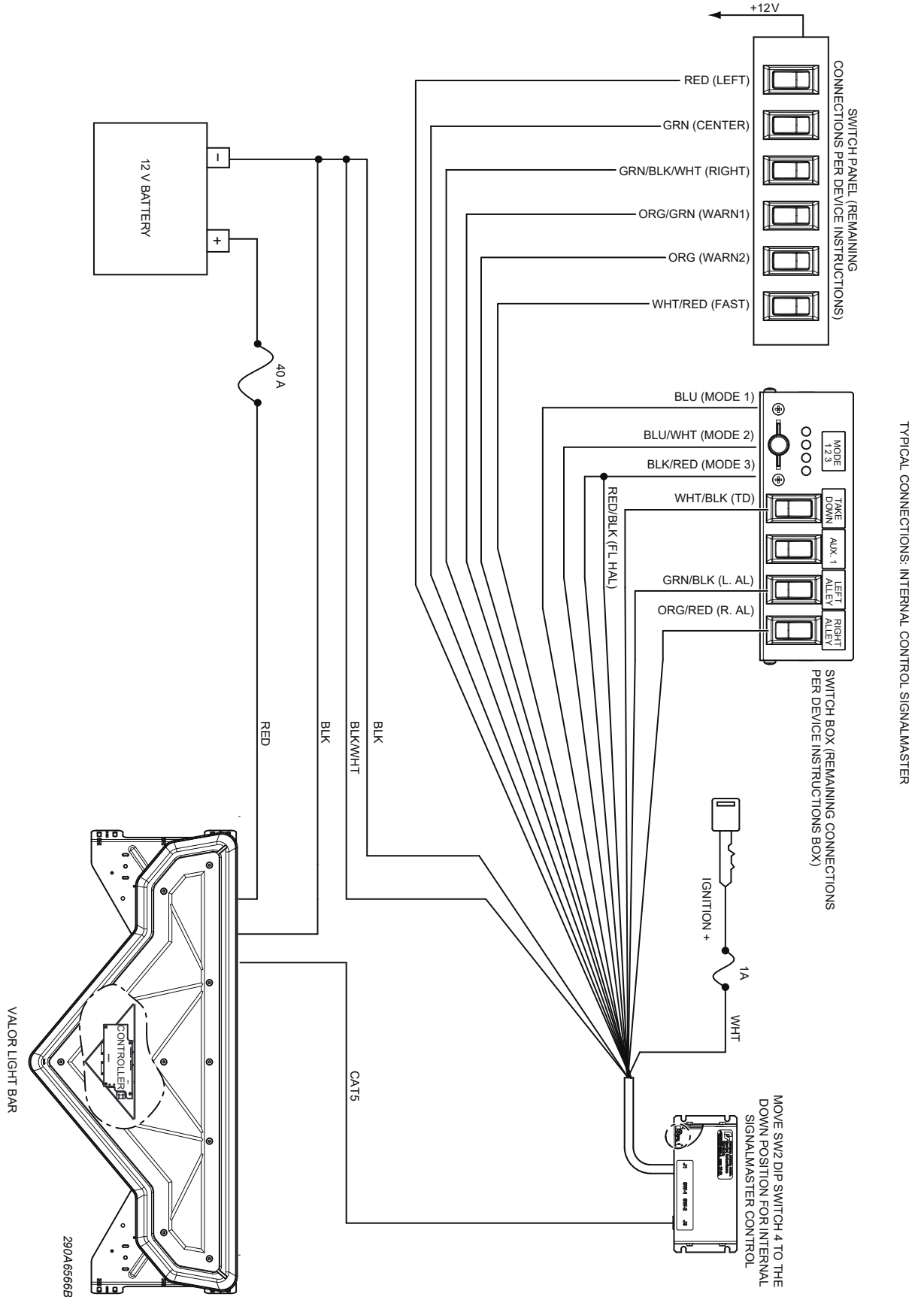
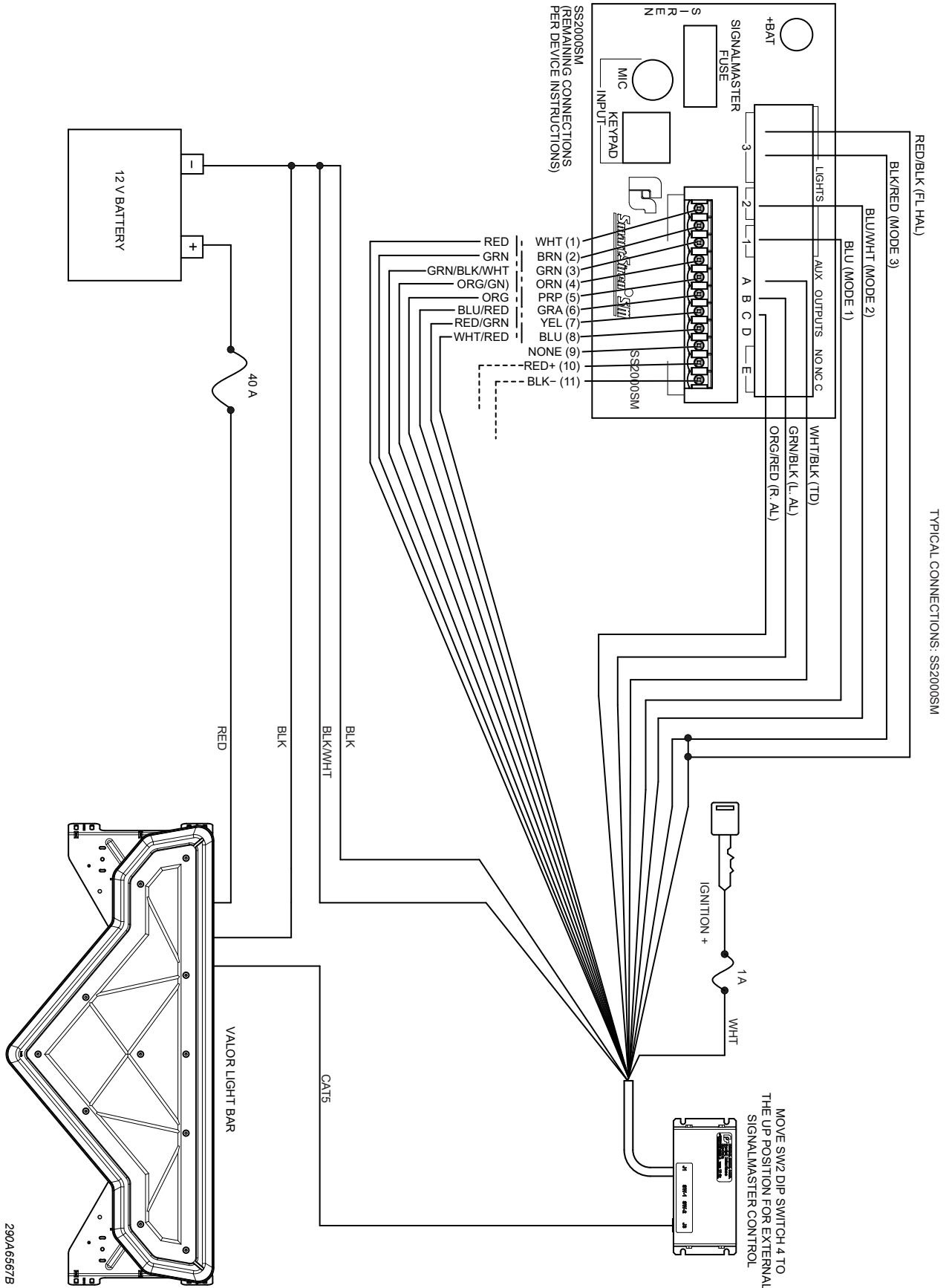

Figure 10 Typical connections with a SmartSiren Model SS2000SM controller



290A6567B

Figure 11 Typical connections with a non-SignalMaster controller

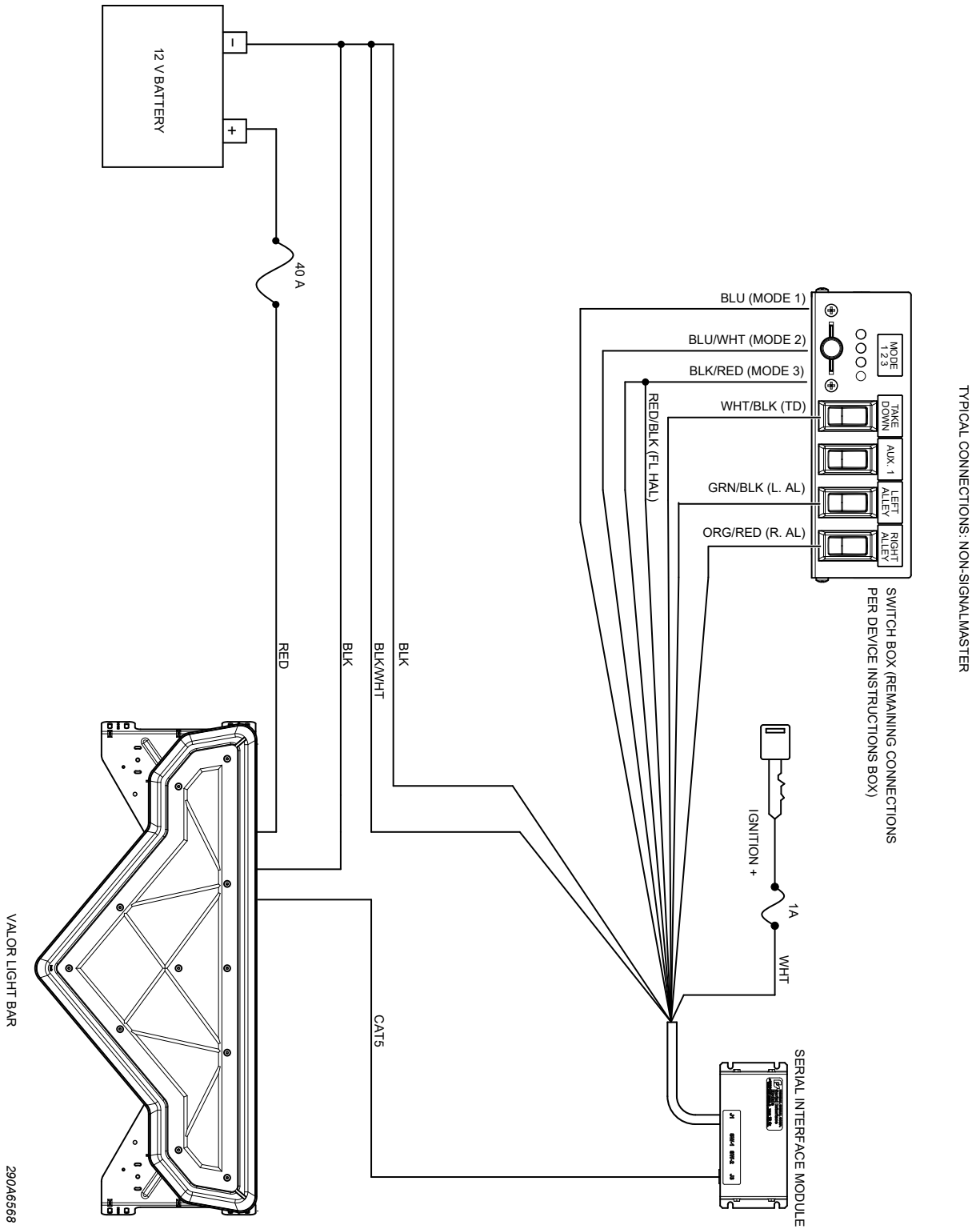
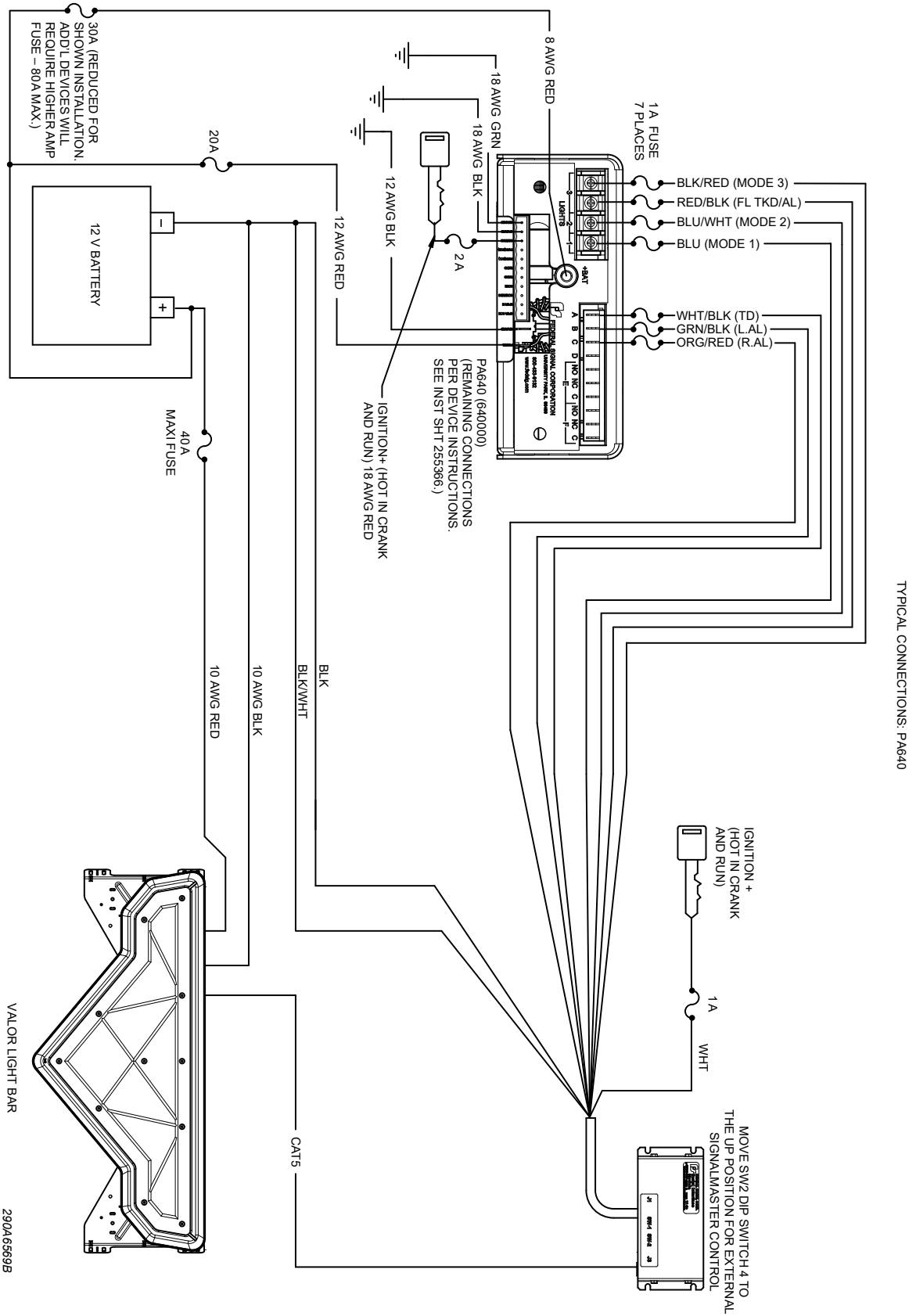

Figure 12 Figure 4.10 Typical connections with a PA640 controller



Maintaining and Servicing the Valor

This chapter describe how to maintain and service the Valor light bar. Establishing a regular maintenance and inspection schedule extends the life of the light bar and ensures safety. For service, support, or replacement parts, contact the Federal Signal Service Department at 1-800-433-9132, 7 a.m. to 5 p.m., Monday through Friday (CT). See Table 9 on page 44 for replacement parts and part numbers.

⚠ WARNING

SHOCK HAZARD: *Disconnect ALL power to the light bar before any maintenance is performed. Failure to do so may result in property damage, serious injury, or death.*

⚠ CAUTION

BURN HAZARD: *After prolonged operation, the unit gets hot and can cause burns. Do not touch the unit while or shortly after it has been operating.*

Cleaning the Light Bar Lens

⚠ WARNING

CRAZING HAZARD: *Crazed, cracked, or faded domes or reflectors reduce the light output and the effectiveness of the lighting system. Tops or reflectors showing this type of aging must be replaced. Failure to follow this warning may result in bodily injury or death to you or others.*

⚠ WARNING

CLEANING SOLUTION WARNING: *The use of cleaning solutions, such as strong detergents, solvents, and petroleum products, can cause crazing (cracking) of the domes and reflectors. Failure to follow this warning can damage the domes and reflectors and may result in bodily injury or death to you or others.*

To clean the light bar lens:

1. Rinse the lens with lukewarm water to loosen dirt and debris.
2. Use a mild detergent, lukewarm water, and a soft cloth to gently clean the lens. To avoid damaging the finish, do not use heavy pressure or caustic, abrasive, or petroleum-based cleaners.
3. Rinse and dry the lens with a soft cloth to prevent water spotting.
4. To remove fine scratches and haze, use a soft cloth and a high quality automotive paste cleaner/wax that is non-abrasive.

Removing and Reinstalling the Light Bar Lens

The light bar lens, which is the top half of the Valor housing, covers the ROC (Reliable Onboard Circuitry) PCBs and controller PCB.

Tool required:

T27 Torx driver

Removing the Lens

To remove the lens:

1. Disconnect all power to the light bar either at the battery or at the light bar. See “Disconnecting/Connecting Power and CAT5 at the Light Bar” on page 38.
2. Use a T27 Torx driver to remove the 1/4-20 Torx-head barrel nuts securing the lens (Figure 13). Carefully remove the lens and gasket as a unit. Avoid damaging the lip seal.
3. Verify that an O-ring is under the head of each barrel nut and not stuck to the lens. Use a wooden or plastic pick to carefully remove the O-rings from the lens to prevent damaging them.
4. Inspect the O-rings and the lip seal for deformation, brittleness, cuts, or tears. To maintain watertightness, replace a questionable O-ring or seal.
5. Inspect the lens for cracks, crazing (hairline cracks) and other defects.

Figure 13 Locations of barrel nuts in light bar cover

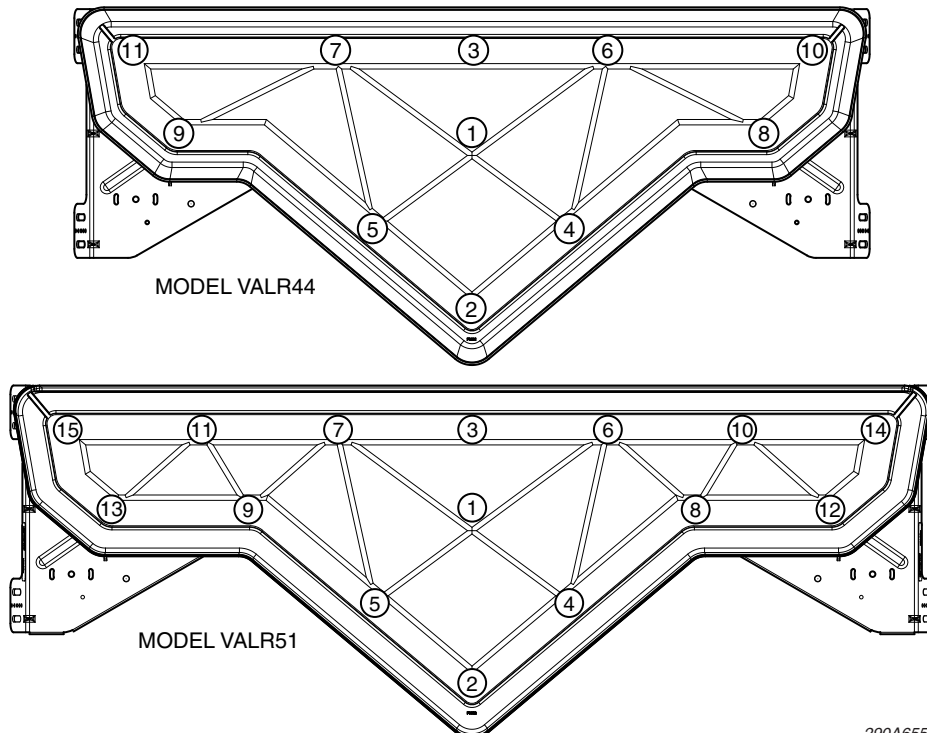

290A6556

Reinstalling the Lens

To reinstall the lens:

1. Reinstall the gasket and lens. To prevent cross-threading the barrel nuts, back them counterclockwise until you hear the click of the threads engaging.
2. Tighten the barrel nuts to 16-24 in-lb in the sequence shown in Figure 13 on page 36.

Replacing a PCB

The Valor light bar has two front, two rear, and two end ROC PCBs as well as a controller PCB (Figure 14). They are configured at the factory per the customer order.

NOTICE

STATIC-SENSITIVE DEVICE: The light bar circuitry can be damaged by electrostatic discharge (ESD). Follow anti-static procedures while installing the light bar.

Tool required:

T27 Torx driver

Removing a PCB

To remove a PCB:

1. Disconnect all power to the light bar at the battery or at the light bar. See “Disconnecting/Connecting Power and CAT5 at the Light Bar” on page 38.
2. Use a T27 Torx driver to remove the 1/4-20 Torx-head barrel nuts securing the lens (Figure 13 on page 36). Carefully remove the lens and gasket as a unit. Avoid damaging the lip seal.
3. Verify that an O-ring is under the head of each barrel nut and not stuck to the lens. Use a wooden or plastic pick to carefully remove the O-rings from the lens to prevent damaging them.

Figure 14 Location of controller

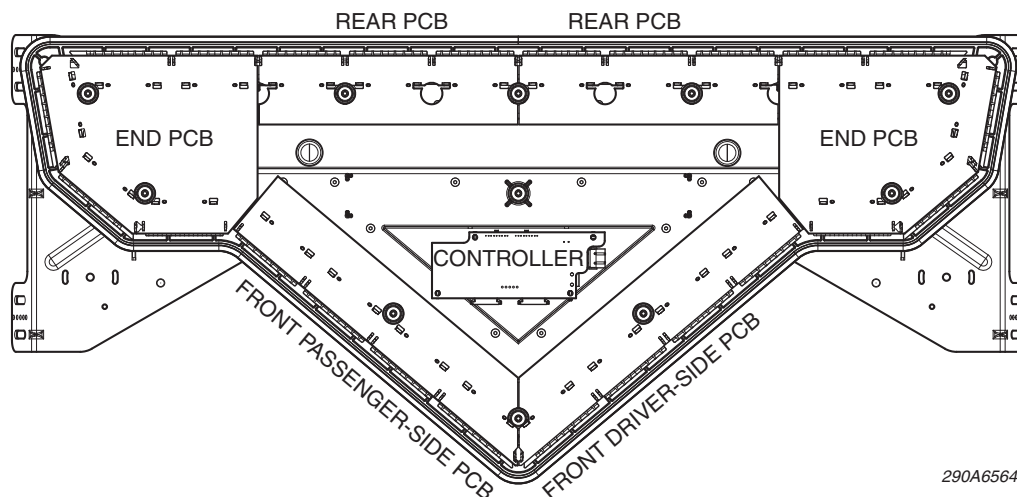

290A6564

4. Inspect the O-rings and the lip seal for deformation, brittleness, cuts, or tears. To maintain watertightness, replace a questionable O-ring or seal.
5. Note and record the connection to the PCB (Figure 14 on page 37), then lift it and disconnect the harnesses.
6. Remove the PCB from the light bar.

Reinstalling a ROC PCB

To reinstall a PCB:

1. Place the new PCB in the same position as the old PCB and reconnect the harnesses.
2. Reinstall the gasket and lens. To prevent cross-threading the barrel nuts, back them counterclockwise until you hear the click of the threads engaging, then tighten them to 16-24 in-lb in the sequence shown in Figure 13 on page 36.
3. Reconnect power to the light bar.

Disconnecting/Connecting Power and CAT5 at the Light Bar

A detachable weather-proof connector at the bottom of the light bar on the passenger side enables you to quickly disconnect both power and ground together without removing the light bar power cables from the battery. The smaller waterproof connector is for the CAT5 communication cable. The connectors, each joining internal two-foot cables leading to the light bar controller, are secured with a secondary lock that prevents disconnection unless the lock is fully disengaged. For instructions on mating and unmating the connectors, see the following pages.

Figure 15 Locations of watertight connectors

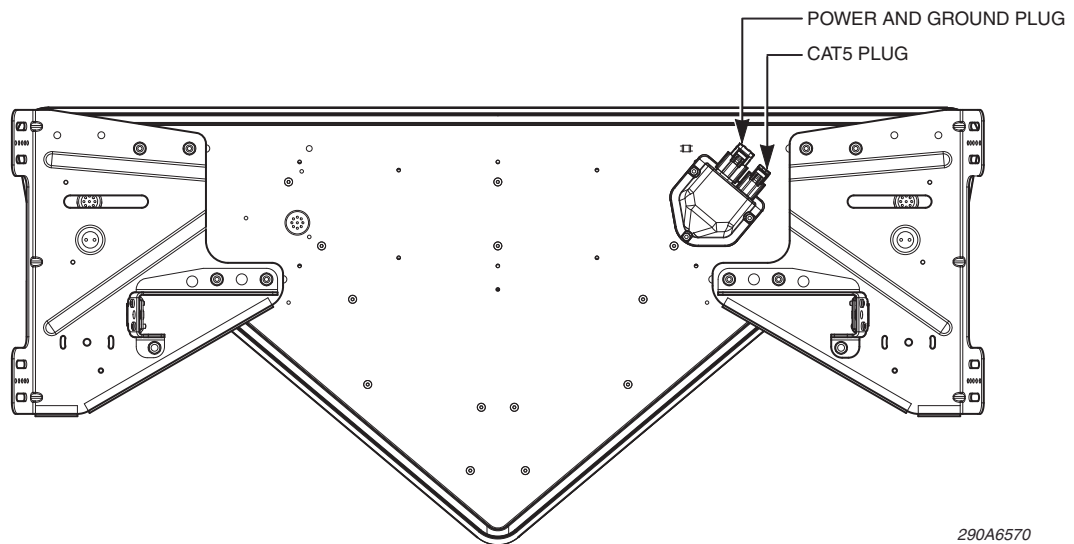
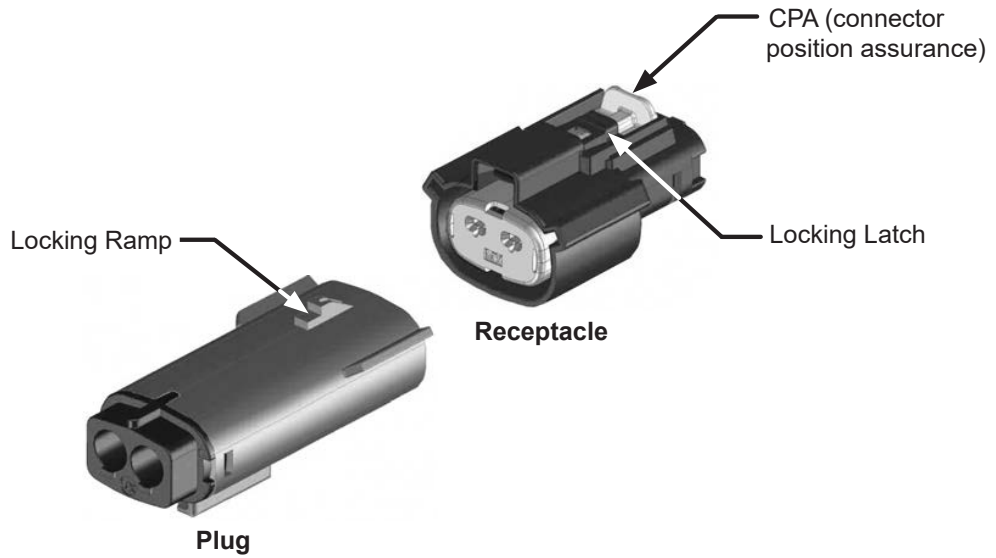

Figure 16 Secondary lock mechanism in the plug and receptacle



Disconnecting a Cable at the Light Bar

To disconnect the power or CAT5 cable:

1. Pull back the CPA on the receptacle.

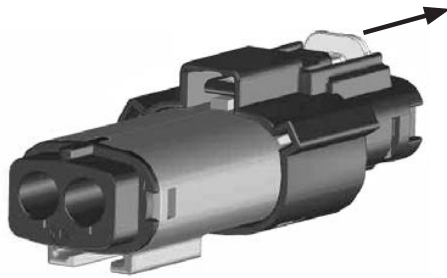

2. Fully press the locking latch. To allow the connectors to be separated, the locking latch must be fully depressed to release the locking ramp on the plug.

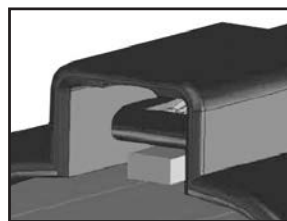
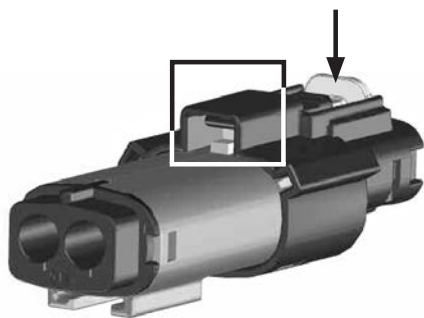

Locking latch in down position: connectors cannot be unmated.

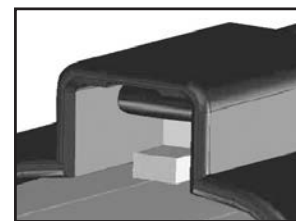

Locking latch is fully depressed: latch releases locking ramp.

3. Pull the connectors apart.

Reconnecting a Cable at the Light Bar

To reconnect the power or CAT5 cable:

1. Firmly push the connectors together until you feel them snap together and you hear a click. This tactile and audible confirmation ensures that the connectors are properly and fully mated.

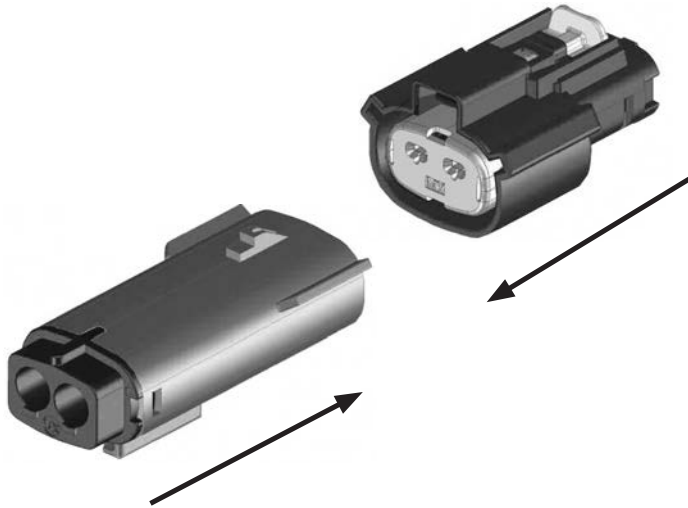

2. Press the CPA towards the plug to engage the secondary lock.

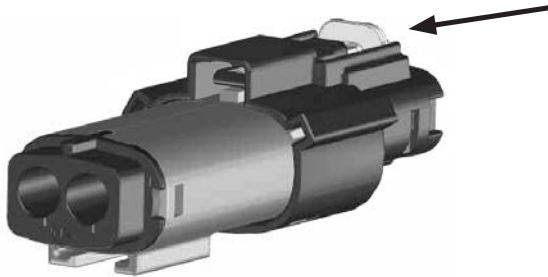

Troubleshooting the Light Bar

This section provides troubleshooting assistance for common problems. If you have any questions left unanswered, call the Federal Signal Service Department at 1-800-433-9132, 7 a.m. to 5 p.m., Monday through Friday (CT).

Table 8 Troubleshooting tips

Problem	Corrective Action
The light bar does not light	<ul style="list-style-type: none"> • Check that the light bar's red power line (+BAT) and the black ground-power line (-GND) are properly connected to a good, fully charged 12-volt battery. Check the 40 A fuse. • Ensure that the ground connection from the light bar controller to the aluminum extrusion is good. • Check that the CAT5 cable is connected to the Serial Interface Module (J1) and there are no damaged pins in the sockets. • Try a new CAT5 cable. • Check the connections on the Serial Interface Module: <ul style="list-style-type: none"> • the black wire and the black/white wire are connected to ground (-GND) • the white wire is connected to 12 Vdc. Check the 1 A fuse. • a MODE wire has 12 Vdc • Check the position of Switch 1 on SW2 in the Serial Interface Module. If Switch 1 is down (ON), ensure that the ENABLE control wires (green/white and orange/black) have 12 Vdc applied. • Check the positions of the DIP switches in the Serial Interface Module. • Check the fuses on the main bar controller.
An LED module does not light	<ul style="list-style-type: none"> • Swap the LED board with good board to see if the board is bad. • Check the connections of the cable that goes from the light bar controller to the LED ROC board. • Ensure that Steady Burn switches on the light bar controller (SW3 PSR for the passenger side and SW3 DSR on the driver side) are set correctly. • If it is a rear module, check the SignalMaster connections.
Half of an LED module does not light	<ul style="list-style-type: none"> • Replace the ROC board that the LED is on.
The light bar turns off when the Flash Takedown/Alley lights turn on	<ul style="list-style-type: none"> • Ensure that the vehicle battery is fully charged. • Check that the light bar's red power line (+BAT) and black ground-power line (-GND) are properly connected to a good, fully charged 12-volt battery. • Check the red power line (+BAT) and the black ground-power line (-GND) connections in the light bar and vehicle.

Problem	Corrective Action
The light bar has a delayed response to being shut off	<ul style="list-style-type: none"> • Ensure that the connections on the Serial Interface Module are kept separate from strobe supplies. • Check all the ground connections, especially on the Serial Interface Module.
A Flash Takedown/Alley light stays on with ignition power applied	<ul style="list-style-type: none"> • Ensure there is no voltage on the corresponding control wire. • To see if the ROC board is bad, swap it with a similar board. • Swap the cables on the light bar controller outputs with a known good output. If the problem moves to another halogen light, send the light bar controller to Federal Signal for repair.
Takedown/alley lights work, but Flash Takedown/Alley lights do not work	<ul style="list-style-type: none"> • Ensure that 12 Vdc is applied to the takedown and alley (red/black) control wire. • Check the 12 Vdc power and negative ground connections to the light bar to ensure there is enough current.
Only one takedown light turns on	<ul style="list-style-type: none"> • Check the connections from the light bar controller to the ROC boards and ensure they are in the proper locations.
SignalMaster LEDs do not light	<ul style="list-style-type: none"> • Check the switch settings on the Serial Interface Module. Ensure they are both set for the correct operation. • Ensure that Switch 4 on SW2 is in the correct position for the selected operation on the Serial Interface Module and ignition power was removed and reapplied. • Check the connections at the SignalMaster controller. If the controller is a model SS2000SM, ensure that the connector has power and the ground is connected to pins 10 and 11 on the SignalMaster plug.

Quick Testing the Valor with the Light Bar Test

⚠ WARNING

LIGHT HAZARDS: *To be an effective warning device, this product produces bright light that can be hazardous to your eyesight when viewed at a close range. Do not stare directly into this lighting product at a close range or permanent damage to your eyesight may occur.*

IMPORTANT: Ensure that SW2 Switch 3 in the Serial Interface Module is in the up position for the Light Bar Test. The down position is ON for the Scene Light, Right option in light bars with Spectralux Technology (Valor and Valor). For the scene light control wires see Figure 6 on page 28 or Figure 7 on page 29.

NOTE: The Light Bar Test does not test the optional Steady Burn LEDs. To test and configure these LEDs, see “Testing the Steady Burn LEDs (HotFoot Only)” on page 43.

After servicing the light bar, perform the Light Bar Test to ensure that all LEDs light properly by following these steps:

1. Apply 12 Vdc (+BAT) to the Light Bar Test control wire (black/white/red) from the Interface Module.
2. After all LEDs flash in sequence, the Takedown and Alley lights flash.
3. Remove 12 Vdc from the Light Bar Test control wire.

Testing the Steady Burn LEDs (HotFoot Only)

The Steady Burn LEDs are factory configured per the customer order for one of these options:

- No Steady Burn (the LEDs flash with the pattern)
 - Driver-side Steady Burn
 - Driver- and passenger-side Steady Burn
1. Apply 12 Vdc (+BAT) to the red/white control wire for the Steady Burn LEDs and a control wire for Mode 1, 2, or 3 (Table 5 on page 16). The LEDs light and stay on (default setting).
 2. Remove 12 Vdc from the Mode and Steady Burn control wires.

Getting Technical Support and Service

For technical support and service, please contact:

Service Department
Federal Signal Corporation
Phone: 1-800-433-9132
Email: empserviceinfo@fedsig.com
www.fedsig.com

Getting Repair Service

The Federal Signal factory provides technical assistance with any problems that cannot be handled locally.

Any units returned to Federal Signal for service, inspection, or repair must be accompanied by a Return Material Authorization (RMA). Obtain a RMA from a local Distributor or Manufacturer's Representative.

Provide a brief explanation of the service requested, or the nature of the malfunction.

Address all communications and shipments to the following:

Federal Signal Corporation
Service Department
2645 Federal Signal Drive
University Park, IL 60484-3167

Replacement Parts

This section contains a partial list of replacement parts. To order replacement parts, call the Federal Signal Service Department at 1-800-433-9132 or 1-708-534-3400, 7 A.M. to 5 P.M., Monday through Friday (Central Time) or contact your nearest distributor.

Table 9 Replacement parts

Description	Part Number
PCB Assembly End (Configured)	Contact Factory
PCB Assembly, Front (Configured)	Contact Factory
PCB Assembly, Rear (Configured)	Contact Factory
PCB Assembly, Controller (Configured)	Contact Factory
Nut, 1/4-20, Barrel	7065071
Seal, Lip, Lens	8651116
O-Ring, Lens Nut	7067016
Gasket, Lens	8651125
Lens, Clear, 44"	8651101
Lens, Clear, 51"	8651103



FEDERAL SIGNAL Safety and Security Systems

2645 Federal Signal Drive
University Park, Illinois 60484-3167

www.fedsig.com

Customer Support

Police/Fire-EMS: 800-264-3578 • +1 708 534-3400

Work Truck: 800-824-0254 • +1 708 534-3400

Technical Support 800-433-9132 • +1 708 534-3400