



FEDERAL SIGNAL
Safety and Security Systems

FCTBD Models

Two-Way Control System and Status Monitoring

Description, Specifications, Installation, Operation, and Service Manual

Limited Warranty

This product is subject to and covered by a limited warranty, a copy of which can be found at www.fedsig.com/SSG-Warranty. A copy of this limited warranty can also be obtained by written request to Federal Signal Corporation, 2645 Federal Signal Drive, University Park, IL 60484, email to info@fedsig.com or call +1 708-534-3400.

This limited warranty is in lieu of all other warranties, express or implied, contractual or statutory, including, but not limited to the warranty of merchantability, warranty of fitness for a particular purpose and any warranty against failure of its essential purpose.



FEDERAL SIGNAL
Safety and Security Systems

2645 Federal Signal Drive
University Park, Illinois 60484-3617

www.fedsig.com

Customer Support 800-548-7229 • +1 708 534-3400
Technical Support 800-524-3021 • +1 708 534-3400

All product names or trademarks are properties of their respective owners.

Contents

Safety Messages	8
General Description	11
Introduction	11
Overview	11
FCTBD Controller	11
Features.....	13
Two-Way Radio Control	13
Ordering Products.....	13
Specifications	14
Specifications	15
Controllers Specifications	15
Signaling Format Specifications.....	16
Inputs and Outputs.....	17
Battery.....	17
Transceiver Specifications	17
Technical Description	17
Control Board Theory of Operation.....	17
Power Supply.....	17
Chopper Motor Current Sensor.....	21
Overview	21
Circuit Description.....	21
Rotator Motor Current Sensor.....	22
Overview	22
Electrical Specifications for Rotator Motor Current Sensor	22
Connections for Rotator Motor Current Sensor	23
Circuit Description.....	23
Installation	25
Locating the Control Cabinet	25
Installing the Control Cabinet.....	27
Electrical Connections	27
Connecting FCTBD to AC Power.....	28

Connecting the Motor Starter (AC Contactor).....	28
Installing the Sensor	29
Sensor Models.....	29
Installing the Motor Current Sensor	29
Adjusting the AC Motor Current Sensor.....	30
AC Voltage Sensors.....	30
Installing the Antenna.....	32
Pre-operational System Configuration and Testing.....	32
Configuring the FCTBD	32
Testing the Sensors	32
Testing the Motor Current Sensor.....	32
Testing the AC Voltage Sensor	32
Verifying Intrusion Sensor	33
Measuring the Battery Voltage.....	33
Measuring the 12 V Battery Charger	34
Manual Siren Activation	34
Landline Siren Activation (optional).....	34
Transceiver Interface, Alignment, and Siren Activation.....	34
Transmit Level Adjustments.....	35
Adjusting the Receive Level.....	35
Testing Controller Decode Sensitivity	35
Confirming Controller Auto-Reporting	35
Confirming Controller Responds to a Report Request.....	36
Operations.....	36
System Operating Description	36
Siren Activation	36
Site Status Monitoring.....	36
Automatic Reports	37
Growl Test.....	37
FCTBD Controller Board Indicators	37
Options for JP11	39
Transceiver Interface	45
Transmit Audio	45
Receive Audio.....	46

PTT	46
+12 Vdc.....	46
Carrier Detect.....	46
Sensors and Sensor Inputs.....	46
AC Sensor.....	46
Low Battery Sensor.....	46
Digital Inputs for Rotation Sensor	47
Digital Input for Current Sensor	47
Digital Input for Intrusion Sensor.....	47
Digital Input for Pressure Sensor (not used with 2001-130 sirens).....	47
Relay Outputs	47
Speaker Output.....	47
Monitor Received Audio	47
Remote Public Address.....	48
Audio Function Generator Option	48
Landline and Local Button Activation	48
Control Board Power Input.....	48
FCTBD Decoding and Encoding Formats.....	48
Decoding Formats.....	48
DTMF Encoding Format.....	48
Programming Software	49
FSPWARE	49
Commander Software (SFCDWARE)	49
Service and Maintenance.....	49
Preventative Maintenance	49
Monthly Testing	49
Annual Inspection	49
Options	50
Model –240B.....	50
FS-SINAD Option.....	50
Model FCTBD-IP.....	50
Ethernet Board Specifications.....	51
Connections	51
Network Information.....	52

Power Supply and 13.8 V Battery Charger	53
Testing the Power Supply and Charger	54
Replacement Parts	55
Getting Service	56
Appendix A Wiring Diagrams	57

Figures

Figure 1 FCTBD Control Cabinet	11
Figure 2 Control Cabinet Dimensions (Aluminum)	14
Figure 3 Schematic Rotation Current Sensor Board 2005221C.....	24
Figure 4 Typical FCTBD Installation Example	26
Figure 5 Setting the Switch Number Example.....	44
Figure 6 Transceiver Interface Connector P1	45
Figure 7 Serial to Ethernet Board	52
Figure 8 Single Motor Wiring.....	57
Figure 9 T-Bolt Wiring	58
Figure 10 FCTB Wiring Diagram	59
Figure 11 FCTBD-IP Wiring Diagram	60

Tables

Table 1 FCTBD Models.....	13
Table 2 Optional Accessories.....	14
Table 3 Electrical/Environmental	15
Table 4 Dimensions	15
Table 5 Decode Sensitivity	16
Table 6 Signaling Formats	16
Table 7 Inputs and Outputs	17
Table 8 Two A/H Sealed Lead Acid.....	17
Table 9 Electrical Specifications for Rotator Motor Current Sensor	22

Table 10 Environmental and Physical for Rotator Motor Current Sensor.....	22
Table 11 Connectors for Rotator Motor Current Sensor.....	23
Table 12 Sensor kits options	29
Table 13 Thresholds	37
Table 14 FCTBD Controller Board Indicators	37
Table 15 2001 DC Solar mode.....	39
Table 16 2001 DC Non-Solar mode	39
Table 17 FCD Repeater Solar mode	39
Table 18 FCD Repeater Non-Solar mode.....	40
Table 19 Ethernet Board Specifications	51
Table 20 Connectors	51
Table 21 Indicators	52
Table 22 Controls.....	52
Table 23 Specifications	53
Table 24 Connectors	53
Table 25 Test Points	54
Table 26 Indicators	54
Table 27 Replacement Part Numbers	55

Safety Messages

⚠ WARNING

It is important to follow all instructions shipped with this product. This device is to be installed by trained personnel who are thoroughly familiar with the country's electric codes and will follow these guidelines as well as local codes and ordinances, including any state or local noise-control ordinances.

Listed below are important safety instructions and precautions you should follow:

Important Notice

Federal Signal reserves the right to make changes to devices and specifications detailed in the manual at any time in order to improve reliability, function, or design. The information in this manual has been carefully checked and is believed to be accurate; however, no responsibility is assumed for any inaccuracies.

Publications

Federal Signal recommends the following publications from the Federal Emergency Management Agency for assistance with planning an outdoor warning system:

- The "Outdoor Warning Guide" (CPG 1-17)
- "Civil Preparedness, Principles of Warning" (CPG 1-14)
- FEMA-REP-1, Appendix 3 (Nuclear Plant Guideline)
- FEMA-REP-10 (Nuclear Plant Guideline).

Planning

- If suitable warning equipment is not selected, the installation site for the siren is not selected properly, or the siren is not installed properly, it may not produce the intended optimum audible warning. Follow Federal Emergency Management Agency (FEMA) recommendations.
- If sirens are not activated in a timely manner when an emergency condition exists, they cannot provide the intended audible warning. It is imperative that knowledgeable people, who are provided with the necessary information, be available at all times to authorize the activation of the sirens.
- When sirens are used out of doors, people indoors may not be able to hear the warning signals. Separate warning devices or procedures may be needed to effectively warn people indoors.
- The sound output of sirens can cause permanent hearing damage. To prevent excessive exposure, carefully plan siren placement, post warnings, and restrict access to areas near sirens. Review and comply with any local or state noise control ordinances as well as OSHA noise exposure standards, regulations, and guidelines.
- Activating the sirens may not result in people taking the desired actions if those to be warned are not properly trained about the meaning of siren sounds. Siren users should follow FEMA recommendations and instruct those to be warned of the correct actions to be taken.

- After installation, service, or maintenance, test the siren system to confirm that it is operating properly. Test the system regularly to confirm that it will be operational in an emergency.
- If future service and operating personnel do not have these instructions to refer to, the siren system may not provide the intended audible warning, and service personnel may be exposed to death, permanent hearing loss, other bodily injuries. File these instructions in a safe place and refer to them periodically. Give a copy of these instructions to new recruits and trainees. Also give a copy to anyone who is going to service or repair the siren.

Installation and Service

- Electrocution or severe personal injury can occur when performing various installation and service functions such as making electrical connections, drilling holes, or lifting equipment. Therefore, only experienced and qualified electricians should install this product in compliance with national, state, and any other applicable codes, ordinances, and regulations. Perform all work under the direction of the installation or service crew safety foreman.
- The sound output of sirens is capable of causing permanent hearing damage. To prevent excessive exposure, carefully plan siren placement, post warnings, and restrict access to areas near the sirens. Sirens may be operated from remote control points. Whenever possible, disconnect all siren power, including batteries, before working near the siren. Review and comply with any local or state noise control ordinances as well as OSHA noise exposure regulations and guidelines.
- After installation or service, test the siren system to confirm that it is operating properly. Test the system regularly to confirm that it will be operational in an emergency.
- If future service and operating personnel do not have these instructions to refer to and are not properly trained, the system may not provide the intended audible warning, and service personnel may be exposed to hazards that could result in death, permanent hearing loss, or other bodily injuries. File these instructions in a safe place and refer to them periodically. Give a copy of these instructions to recruits and trainees. Also give a copy to anyone who is going to service or repair the siren.

Operation

Failure to understand the capabilities and limitations of your siren could result in permanent hearing loss, other serious injuries, or death to persons too close to the sirens when you activate them or to those you need to warn. Carefully read and thoroughly understand all safety notices in this manual and all operations-related items in all instruction manuals shipped with the equipment. Thoroughly discuss all contingency plans with those responsible for warning people in your community, company, or jurisdiction. A well-written contingency plan document is recommended.

Hazard Classification

Federal Signal uses signal words to identify the following:

DANGER

DANGER indicates a hazardous situation which, if not avoided, will result in death or serious injury.

WARNING

WARNING indicates a hazardous situation which, if not avoided, could result in death or serious injury.

CAUTION

CAUTION indicates a hazardous situation which, if not avoided, could result in minor or moderate injury.

NOTICE

NOTICE is used to address practices not related to physical injury.

Read and understand the information contained in this manual before attempting to deploy or service the siren.

Pay careful attention to notices located on the equipment.

General Description

Introduction

This manual describes the features, specifications, technical description, installation, operation, maintenance, and options of the Federal Signal two-way controller (model FCTBD). The FCTBD controller can control and monitor any electro-mechanical siren and may be used in conjunction with the SS2000+ or Federal Signal Commander® System located at a central command point.

Figure 1 FCTBD Control Cabinet

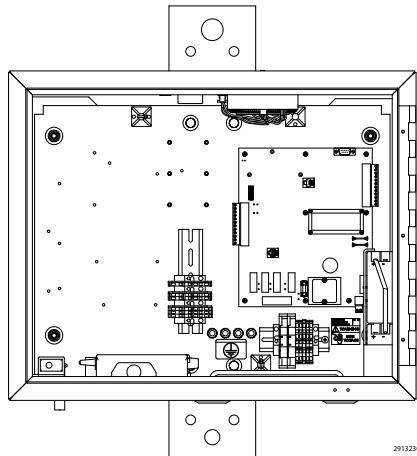

Overview

The Control Cabinet consists of a NEMA 4 cabinet. The cabinet houses an aluminum backplane on which the following are mounted:

- FCTBD Controller Board
- Power supply
- Battery
- Radio

If required, the antenna system is not included with the radio controller models. The appropriate directional or omni-directional antenna system must be ordered separately.

FCTBD Controller

The FCTBD is a two-way control and status monitoring controller. The unit interfaces to a two-way radio transceiver and communicates to a base control unit through either DTMF or FSK signaling depending on the model purchased.

The controller decodes any combination of Single-Tone, Two-Tone Sequential, DTMF, EAS, POCSAG, or FSK for activation. This makes the two-way controller compatible with virtually any existing siren control system.

The digital FCTBD provides the capability of digital encoding and decoding with added security. Throughout this manual, all references to digital encoding, digital decoding, and FSK features and functions pertain only to the FCTBD models. You can upgrade the DTMF version of the FCTB to the digital version of FCTBD with a software update.

General Description

All FCTBD models come equipped with four relay outputs that you can program independently to activate with various codes. Relay #3 is wired as a normally closed contact and is used to force the system into battery mode during a growl test (if applicable). Relay #4 is reserved as a low-voltage disconnect.

There are also four inputs and four local buttons, which you can use to activate and cancel the unit remotely. A fifth button is reserved as a Reset button.

The function codes, relay timing, and optional warning sounds are programmed into the unit through a standard RS232 serial port with FSPWARE or SFCDWARE programming software.

The FCTBD contains six user-programmable functions in addition to the five preset functions: ARM, DISARM, REPORT, QUIET TEST/GROWL TEST, and MASTER RESET.

The FCTBD comes equipped with the necessary sensors and wiring to provide information on the following areas of operation:

- AC Power Status
- Controller Status
- FCTBD Battery Voltage Indication
- Intrusion into FCTBD Control Cabinet
- Siren Motor Current
- Charger Status
- Rotation Motor Current*
- Blower Motor Current*

* when applicable

The above information is returned in a Pass/Fail format. For example, if the battery voltage is at a proper operating level, then it is returned as "Battery Voltage OK." This status information is made available for viewing at the Central Control Unit. This reporting feature greatly improves warning system reliability by quickly alerting operating personnel to problems that are encountered.

The Integral LCD displays Function Counters, Decoded Two-Tone, DTMF, POCSAG, MSK Digital functions decoded, and the current software revision. The display constantly scrolls through the display items.

Features

The FCTBD Controller has the following features.

- Two-way control, activation, and status monitoring
- Four individually programmable output relays
- Six built-in siren tone signals for PA/Intercom
- External inputs for sensors and activation
- Buttons for local activation
- Internal battery back-up
- 120 or 240 Vac power
- UL and cUL listed, and DNV certified
- Simultaneous two-tone sequential, DTMF, EAS, POCSAG, and digital AFSK decoding for security

Two-Way Radio Control

The FCTBD uses radio transceivers to provide two-way signaling capabilities. Refer to the radio instruction manual for details concerning operation, specifications, and maintenance. For specialized radio equipment needs, contact Federal Signal Customer Support.

Ordering Products

For special orders, contact Federal Signal. See “Getting Service” on page 56 for contact information.

Antenna and cable are not included with the radio activation control and must be ordered separately.

For information about recommended cables for the radio, refer to Recommended Cables for Radio sheet (SYS5060) on www.fedsig.com.

The following table lists the standard FCTBD part numbers.

Table 1 FCTBD Models

FCTBD Model	Description
FCTBD	Two-way Controller with FCMPPlus Control Board and radio
FCTBDH	Two-way Controller with FCMPPlus Control Board and radio, High Band 148-174 MHz radio
FCTBDU	Two-way Controller with FCMPPlus Control Board and radio, UHF Band 403-470 MHz radio
FCTBD-IP	Two-way IP-enabled Electro-mechanical Controller

Specifications

Table 2 Optional Accessories

Accessories	Description
FSPWARE	Windows® programming software (Non-digital applications)
SFCD10/25/255/512	Commander® Software System, *10, 25, 255, or 512 Site License
FS-PL1	Private line tone and digital coded squelch decoder
FS-PL2	Encoder and decoder (low)
SS2000+	Hardware Controller
TB-LL	Telco base, landline
SK-SM	Single motor AC current sensor
SK-3M	Three motor AC current sensor
SK1-120	Single phase, 120 Vac voltage sensor
SK1-240	Single phase, 240 Vac voltage sensor
SK3-240	3-phase, 240 Vac voltage sensor
SK3-480	3-phase, 480 Vac voltage sensor

Specifications

Figure 2 Control Cabinet Dimensions (Aluminum)

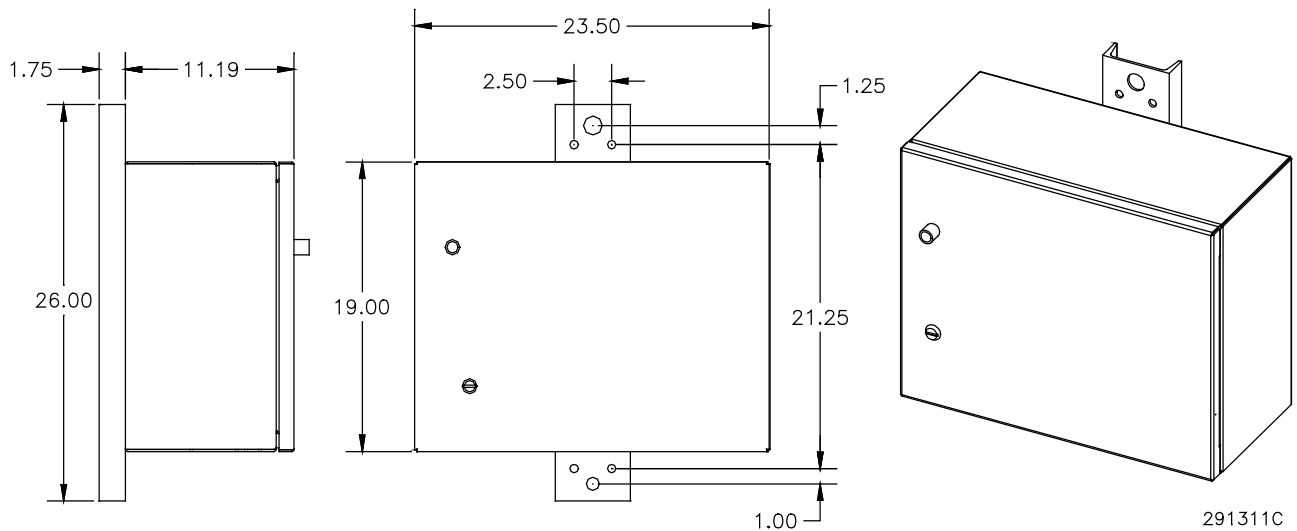

Specifications

Controllers Specifications

Table 3 Electrical/Environmental

Input Power Requirements	
AC Voltage With –240B option	120 Vac +/- 10%, 50-60 Hz or, 208-240 Vac, 50-60 Hz
Current draw	4.0 A at 120 Vac (maximum) 2.5 A at 240 Vac (maximum)
48 Vdc Input	15-75 Vdc, 400 mA max at 48 Vdc
12 Vdc Input	11-15 Vdc, 400 mA max at 12 Vdc
Back-up Battery	
DC Voltage input range	11.5-18.0 Vdc
Current draw with AC present without AC (back-up mode) with two-way radio	none 150 mA (without two-way radio) (Transceiver is 350 mA in Standby, 8 A transmit typical – refer to radio specifications for the actual radio model in use.)
Charger/Power Supply	
AC Input	102-132 Vac or 204-264 Vac, 50-60 Hz
Battery Charger Output	13.75 Vdc +/-2%, 1 A maximum
Power Supply Output	13.8 Vdc +/-5%, 10 A maximum
Current Limiting	Protected with automatic recovery
Serial Communications	
Serial Port Configuration	RS232C 1200, N, 8, 1
I ² C	
I ² C	Phillips I ² C Standard
Environmental	
Operating Temperature	-30°C to +65°C (-22°F to 149°F)
Humidity	0-98% non-condensing

Table 4 Dimensions

Control Cabinet (NEMA 4) (H x W x D)	19.00 x 23.50 x 11.19 inches (483 x 597 x 284 mm)
Total Weight	95 pounds (43.2 kg)
Shipping Weight	155 pounds (70.5 kg)
Finish	Aluminum (Stainless steel also available)

Signaling Format Specifications

Table 5 Decode Sensitivity

Duotone	$\leq 18\text{ dB SINAD}$ (except with CTCSS tones > 200 Hz and decode tones < 400 Hz)
DTMF	$\leq 21\text{db SINAD}$
EAS	$\leq 21\text{db SINAD}$
POCSAG	$\leq 21\text{db SINAD}$
FSK	$\leq 21\text{db SINAD}$

Table 6 Signaling Formats

Two-Tone Sequential Frequency range Tone timing Inter-tone Gap Tone Accuracy Tone Spacing	282-3000 Hz First tone: 0.5 seconds minimum Second tone: 0.25 seconds minimum 6.25 seconds maximum 400 ms (maximum) +/- 1.5% 5.0% preferred, 3% minimum
Single Tone Frequency range Tone timing Tone Accuracy Tone Spacing	282-3000 Hz 6.25 seconds maximum +/- 1.5% 5.0% preferred, 3% minimum
DTMF String length Mark/Space timing: Decoder Minimum Decoder Maximum Encoder Space between Stacked codes, minimum	All timings in milliseconds 3-12 standard DTMF characters 50 ms/50 ms (below 50/50 consult factory) 800 ms total mark/space timing per code 50 ms/50 ms mark/space timing 1.25 seconds
FSK Baud rate Modem type Mark frequency Space frequency Error checking	1200 bps MSK (minimal shift key) 1200 Hz 1800 Hz 16 bit CRC
EAS	Supports standard EAS codes and wildcards
POCSAG	Supports Binary frequency shift keying 512 Baud numeric messages

Inputs and Outputs

Table 7 Inputs and Outputs

Relay Outputs	
Four relay outputs	SPST (2 relays standard, 1 relay reserved for low voltage cutout)
Contact Rating	240 Vac, 5 A or 24 Vdc, 8 A
Audio Output (Optional)	
Output Voltage	> 2 V _{P-P}
Maximum Load	8 ohms
Total Harmonic Distortion	< 10% at 1 kHz Sine wave
Remote Activation Inputs	
Number of Remote Activation Inputs	4
Number of Remote Sensor Inputs	8
Input Type	6 each, dry Contact closure < 1 k ohm, 2 each, analog voltage inputs

Battery

Table 8 Two A/H Sealed Lead Acid

Battery Backup Capability	12 hours minimum
Terminals	Quick disconnect spade type POSITIVE = 0.250 in x 0.032 in

Transceiver Specifications

Refer to the radio owner's manual for product specifications.

Technical Description

Control Board Theory of Operation

Power Supply

MOVs V5, V6, and V7

The control unit can be powered by either 110 Vac or 220 Vac (on JP22). The control unit is protected by MOVs V9, V10, and V11, resistors R150 and R151 and by fuse F3. These absorb spikes and limit over-voltages. The power is stepped down by the transformer, rectified by D82, and filtered by C112. The voltage at this point is about 24 volts DC. Transorb D83 blows fuse F1 if the voltage exceeds 33 Vdc. This voltage is regulated to 12 Vdc by switching regulator U35. This voltage turns on Q11 through R133. The collector of Q11 sends a low to U34 pin 8, indicating the presence of AC Power.

DC Power Input and Low Voltage Cutout

U35 can also be powered by up to 75 Vdc through JP5 pin 9 from an external DC source. The 12 Vdc from U35 turns on Q10 through R130. This pulls the gate of switch Q9 low, allowing it to pass voltage from the 12-volt battery through Q9 to the rest of the board if needed due to a power failure. The passed battery voltage turns on Q12 through R137 and Zener diode D72. Q12 also pulls the gate of Q9 low, turning it on. If AC power fails, Q10 releases its low to Q9. Then if the battery voltage drops below about 9.6 Vdc, Q12

Technical Description

releases its low to Q9. This turns off the power to the board, which stays off until AC power is restored.

Regulated Supplies

U32 regulates the voltage further to 8 Vdc. U33 regulates the voltage further to 5 Vdc, and U30 regulates it to a further 3.3 Vdc. An LED (D26) is tied to the 5 volts supply and indicates power. The regulated 12 volts pass through 12-volt regulator U44, which acts to limit the maximum voltage supplied to U40 and U43. U43 is an isolated DC to DC converter, which converts the 12-volt supply to an isolated 5-volt supply. This is used for sensor and remote activation inputs. LED (D77) is also tied to this point and indicates isolated 5-volt power.

U40 is an isolated DC to DC converter, which converts the 12-volt supply to an isolated 12-volt supply. This is used for relay outputs. An LED (D79) is also tied to this point and indicates isolated 12-volt power. The Heartbeat signal from the processor passes through C107 and D80, keeping C110 charged and Q14 on. This keeps Q15 on, allowing power to pass to U43, which powers the relay outputs. If the processor stops running, R148 will discharge C110 and turn off Q14 and Q15. This removes power from the relays, so they cannot activate.

U41 monitors the voltage of the 5-volt power. If the power supply voltage falls below 3.3 volts, U14 resets the microprocessor.

Remote Activation, Sensor, and Battery Back-up Voltage Input

The remote activation inputs are available on connector JP10. Grounding any one of these pins activates the function associated with it. The inputs are protected by limiting diodes and are optically isolated. There is also a button on the board for each of these functions that activate the associated input.

The sensor inputs are available on connectors JP10 and JP5.

Rotation, Intrusion, Pressure, Current, and Spare sensor inputs #1 and #2 are all active low (shorting to isolated ground). When one of these inputs is shorted to isolated ground, the output of the associated optical-isolator pulls low. This is read by the processor. The 12-volt and 48-volt sensor inputs are analog voltages that are buffered by U15 and then passed on to the A to D convertors in the processor to be read. These are not optically isolated and are referenced to ground.

The TR Voltage sensor input is an analog voltage that is buffered by U38 and then passed on to the A to D convertors in the processor to be read. It is not optically isolated and is referenced to ground.

For an External Transceiver

The receive audio from P1 pin 2 (the two-way connector) is routed to the output, which is set to $1 V_{p-p}$ at TP6 using R27. The CTCSS decoder option, if installed, gates U11:C on and allows audio to pass. U1B forms a highpass filter. This strips out any audio frequencies below 300 Hz. This filtered audio is then fed to the various decoders.

For an Onboard One-Way Receiver

The receive audio enters through U9:C and R60 to Carrier Detect Gate U11A and then to U1A. The output is about $1 V_{p-p}$ at TP6. The CTCSS decoder option, if installed, gates U11:C on and allows audio to pass. U1B forms a highpass filter. This strips out any audio frequencies below 300 Hz. This filtered audio is then fed to the various decoders.

Receiver Priority

Jumper JP4 sets the priority if an external transceiver and an onboard receiver are both used. The receiver with priority can interrupt the other receiver, and its audio passes through to the rest of the circuits in the controller. The receiver with priority cannot be interrupted. If neither receiver is given priority, then whichever receiver asserts carrier detect first will pass through, and the other receiver will not be able to interrupt it.

If the “EXT” side is jumpered, then the external transceiver has priority. When it asserts carrier detect, the low passes through D9, setting the output of U10:B high and turning on audio gate U11:D. This allows the received audio to pass through U11:D to U1A; the output goes to the decoder circuits. The high from U10:3 also passes through R25 to U10:B, which forces audio gate U11:A off, thus preventing audio from the onboard receiver from coming through.

If the “INT” side is jumpered, then the onboard receiver has priority. When it asserts carrier detect, the low passes through D4, setting the output of U10:B high and turning on audio gate U11:A. This allows the received audio to pass through U11:A to U1A; the output goes to the decoder circuits. The high from U10:4 also passes through R25 to U10:A, which forces audio gate U11:D off, preventing audio from the external transceiver from coming through.

VOX

JP3 can be jumpered to provide VOX carrier detect for radios that do not provide carrier detect. Receive audio is routed from the external transceiver connector to buffer amplifier U2A, which drives RMS to DC converter U4B. The DC voltage at the cathode of D6 represents the level of the incoming receive audio. U4A acts as a comparator whose output pulls low when the receive audio exceeds about $45 mV_{p-p}$ or about 750 Hz of deviation (350 Hz for narrowband systems). This passes to JP3, which can be jumpered to provide VOX carrier detect for radios that do not provide carrier detect.

DTMF

Receive audio enters the DTMF decoder IC (U14) from the high pass filter through C51 and R64. When a proper DTMF digit is being decoded, TP8 will go low, and a binary output will appear on pins 18, 19, 20, and 20 of U14.

POCSAG Decode

All POCSAG messages contain a Receiver Identity Code (RIC) or CAP code. This indicates which unit or group of units a message is intended for. The unit must have its RIC configured before it responds to a message.

The Standard Format for Federal Signal POSAG codes consists of a five-character numeric message preceded by a bracket “[” and followed by a bracket “]” for a total of seven characters. The first three numbers are the unit number. Any unit number less than 300 activates only that unit number. A unit number of 300 activates all units. A unit number of 301 to 316 activates all units in zones 1 to 16 respectively. The unit must be configured for the zone in which it is to function.

Technical Description

The last two numbers in the message are the function number (01 through 06), which activates functions one through six. Function numbers 96, 97, 98, and 99 activate Poll All, Reset, Quiet Test, or Cancel respectively.

Receive audio from the receiver module enters on JP7, pin 8. This audio is direct coupled and passes through lowpass filter U5A. R11 and C35 average the DC voltage present on U5A pin 1 and pass it to U5B pin 6. U5B acts as a comparator converting the audio present on pin 5 into square waves. This is fed to the processor for decoding.

Transmit Audio and PTT

The transmit audio is generated by U14 (the DTMF encoder), U12 (the digital encoder), and the CTCSS board (if present). PTT is generated by the processor taking pin 44 low. This gates U11:B on, allowing the transmit audio to pass out to the transmitter.

The PTT also sets the collector of Q4 high, which allows R47 to turn on Q3 through R44. Q4 pulls the PTT line low and activates TRANSMIT LED D18. The collector of Q4, being high, also allows R48 to begin charging C15. When this exceeds 5 volts, U3A forces its output to ground and shuts off Q3. This provides a time-out timer to prevent the transmitter from getting stuck in transmit.

The PTT signal also sets the output of U17F high, turning on Q5. This sends a ground to the CTCSS board, telling it to encode rather than decode.

Serial Ports

Transmit serial data from pin 3 of the micro (U28) passes through switch U24 to U31 - pin 7, which converts the TTL level to +/- 12 volts RS232 levels and passes the transmit data to serial port JP8. Receive data from JP8 is likewise converted from RS232 levels to TTL levels and sent through switch U24 to the micro on pin 2.

Transmit serial data from pin 13 of the micro (U28) and RTS from pin 14, pass to U42 - pins 7 and 10, which converts the TTL levels to +/- 12 volts RS232 levels and passes them to auxiliary serial port JP16. Receive data and CTS from JP8 are likewise converted from RS232 levels to TTL levels and sent to the micro on pins 12 and 15.

Relay Outputs

There are four relay outputs that are controlled by the processor. They are driven through opto-isolator U37 and spike protected to prevent voltage spikes from affecting the unit. The outputs appear on a connector at the bottom of the board with contact ratings up to 5 A and 240 Vac RMS. K3 and K4 outputs have jumpers to select if they are to be operated only when the unit is Armed (the unit has been activated) or anytime without being Armed.

Speaker Output

The microprocessor (U28) generates warning sounds on pin 26, which are routed out through amplifier U16 to the speaker output JP2.

Chopper Motor Current Sensor

Overview

The adjustable current sensor 2001062B is a window comparator device that uses a current sensor and window comparator. The output is opto-coupled and the circuit is powered by a voltage regulator. The ground for the circuit is selected by way of jumper J2 between isolated or earth ground. The operation of the circuit is such that if the current passing through the probe of the current sensor is larger than the lower preset level and is less than the upper preset level, an active high output results in turning on the opto-coupled output, indicating that the sensed current is within the acceptable range.

Circuit Description

The circuit is energized when 12 Vdc (nominal) is applied to J1-3 and ground is applied to J1-1. The 12 Vdc at J1-3 is applied directly to the voltage regulator. The regulated 8 Vdc output of IC1 is applied to the dual op amp at pin 8 and also to the Hall-Effect current sensor at its (+) input.

Current probe CS1 is designed to generate a reference voltage of 1/2 the supply voltage on its (0) output pin. With 8.0 Vdc at the (+) input of CS1 and ground applied at the (-) input of CS1, CS1 outputs 4.0 Vdc on the (0) output when the current passing through the probe of CS1 is zero. This voltage is applied to R2, through which C4 is charged to 4.0 volts, and this voltage is applied to the non-inverting input of IC2B and the inverting input of IC2A. The output of the current sensor is linearly scaled such that a change of 100 A in sensed current results in a change of 1.0 volt at the output, and a change of 1.0 A results in a change of 0.01 volts at the output. Using this calibration, you can adjust the POT1 and POT2 to set upper and lower current thresholds, respectively.

A typical application of the current sensor could be to set the device for an upper current threshold of 300 A and a lower current threshold of 50 A.

Using these values, the voltage at TP1 corresponding to 300 A is the following:

$$4.0 \text{ V} + (300 \text{ A} * 0.01 \text{ V/A}) = 7 \text{ V}$$

The voltage at TP1 corresponding to 50 A is the following:

$$4.0 \text{ V} + (50 \text{ A} * 0.01 \text{ V/A}) = 4.5 \text{ V}$$

Adjusting POT1 sets the upper current threshold voltage of 7 V at TP2, and adjusting POT2 sets the lower current threshold voltage of 4.5 V at TP4. With a sensed current value between 50 and 300 A, the voltage at TP1 is between 4.5 and 7 volts. Since the voltage at the inverting input of IC2B (pin 6, also TP2) is set to 7 volts, and the voltage at the non-inverting input (pin 5) is less than 7 volts, the output of IC2B (pin 7) is logic low. Similarly, since the voltage at the non-inverting input of IC2A (pin3, also TP4) is set to 4.5 volts, and the voltage at the inverting input (pin 2) is greater than 4.5 volts, the output of IC2A (pin 1) is also logic low.

The outputs of IC2A and IC2B are applied directly to the inputs of NOR gate IC3. With a logic low at both inputs of IC3 (pins 1 and 2), the output of IC3 at pin 3 is a logic high, approximately 8 volts. 8 volts applied through R1 to the input (pin 1) of opto-coupler IC4 causes the output transistor of IC4 to be saturated and a logic low is applied to J1-2, indicating that the sensed current is within the preset acceptable range.

In the case that the sensed current exceeds the upper current limit, the voltage at TP1 is larger than 7 volts, putting the non-inverting input of IC2B at a higher potential than the inverting input, resulting in a logic high at the output of IC2B, which is applied to pin 1 of IC3. A logic high at either or both inputs of IC3 yields a logic low at the output of IC3, which causes the output transistor of IC4 to be cut off, and a logic high is applied to J1-2, indicating that the sensed current is outside the acceptable range. J2-1 must be pulled high by whatever circuit it is connected to. Similarly, if the sensed current falls below the lower current limit, the voltage at TP1 is less than 4.5 volts, putting the inverting input at a lower potential than the non-inverting input, resulting in a logic high at the output of IC2A, which is applied to pin 2 of NOR gate IC3. As described above, this results in an active high applied to J1-2, indicating that the sensed current is outside the acceptable range.

Rotator Motor Current Sensor

Overview

The Current Sensor board is a convenient snap-track mountable way to measure DC currents in the 0 to 10 ampere range. It scales the voltage reading to allow direct reading of the current passing through the sensor and employs a window comparator, which signals that the current is between a lower and an upper limit.

Features:

- Easy direct reading of current passing through the sensor
- Jumper selectable fixed window comparator, no adjustment needed
- UNDER, GOOD, and OVER indication LEDs
- Accurate to +/- 5% at 2 to 8 ampere DC

Electrical Specifications for Rotator Motor Current Sensor

Table 9 Electrical Specifications for Rotator Motor Current Sensor

Input Voltage	12.5-20 Vdc
Input Current	< 80 mA maximum
Measurement Accuracy	+/- 10% at 0.5-1.0 A +/- 5% at 2-8 A
Measurement Current Ranges	0-10 A, 0-10 Vdc at TP3
Window Comparator Thresholds	Selectable: from 0.33-5.0 A for the minimum to 2.0-10.0 A for the maximum
Window Comparator Output	Open collector, sink <= 10 mA

Table 10 Environmental and Physical for Rotator Motor Current Sensor

Environmental	
Operating Temperature	-30°C to +65°C (-22°F to 149°F)
Humidity	0-98% non-condensing
Size	2 x 3 inches
Weight	< 6 oz

Connections for Rotator Motor Current Sensor

Table 11 Connectors for Rotator Motor Current Sensor

JP1	Current Measurement Pass-Through 2(+) voltage source 1 0-10 A output to motor
JP2	Lower Threshold Selection 15 and 16 0.33 A 13 and 14 1 A 11 and 12 1.5 A 9 and 10 2.0 A 7 and 8 2.5 A 5 and 6 3 A 3 and 4 4 A 1 and 2 5 A
JP3	Upper Threshold Selection 19 and 20 2 A 17 and 18 3 A 15 and 16 4 A 13 and 14 5 A 11 and 12 6 A 9 and 10 7 A 7 and 8 8 A 5 and 6 9 A 3 and 4 10 A 1 and 2 Disable Upper Threshold
JP4	Ground Select Jumpered ties isolated ground to circuit ground
JP5	Interface, Power In and Signal Output 1 Circuit Ground 2 Window comparator output, open collector, pulls low when current is above min and below max current 3 DC supply voltage input (12-35 Vdc) 4 Iso Ground

Circuit Description

Power Supply

Power enters through D1, is regulated down to 5 Vdc +/- 2% by U4, and is filtered by C2 and C3.

Current Measurement Path

The current sensor, U1, outputs a fixed DC voltage (2.5 V) plus a variable voltage representing the current being measured. For the 0 to 5 ampere input a 2 ampere current draw would = 2.5 Vdc + 0.625 Vdc or 3.125 Vdc.

U3B generates an offset voltage. This voltage is summed through U3A with the voltage from the current sensor. This subtracts off the 2.5 Vdc from the current sensor leaving only the voltage representing the current being measured. U3A multiplies this voltage and scales it so that 1 ampere of current being measured = 1 Vdc at TP3 (3 A = 1 Vdc for the 0-15 A input). The output of window comparator U2A and U2B goes high if the voltage is greater than the voltage at U2 pin 6 and less than the voltage at U2 pin 3. This turns on Q1 which pulls the output at JP2 pin 2 low.

Figure 3 Schematic Rotation Current Sensor Board 2005221C

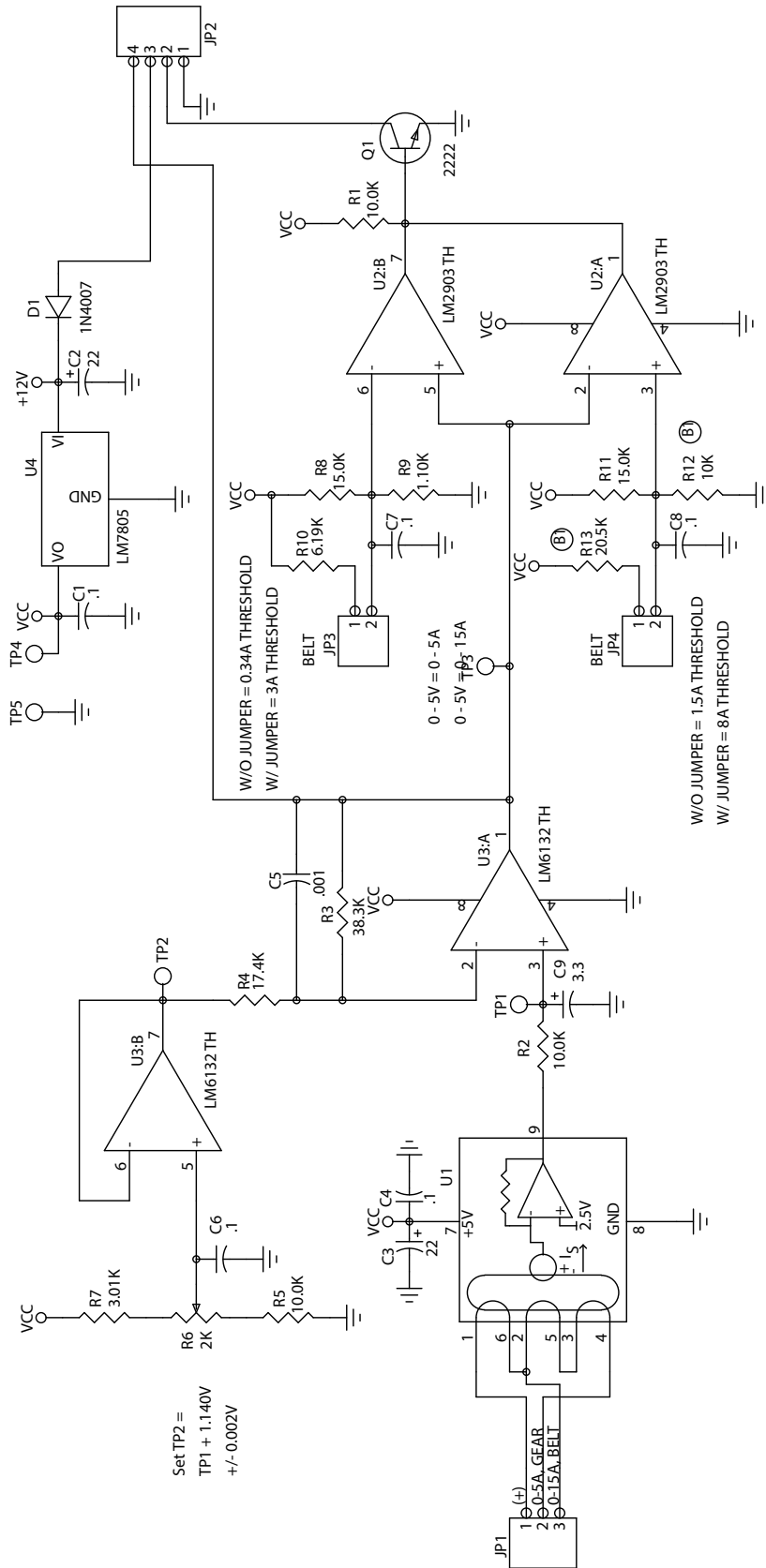

All Values are in:
uF, Ohms & mHz
unless otherwise noted

Installation

⚠ DANGER

ELECTROCUTION HAZARD: *Electrocution or severe personal injury can occur when making electrical connections, drilling holes, or lifting equipment. Therefore, experienced electricians, per national and local electrical codes, acting under the direction of the installation crew safety foreman, should perform the installation.*

EXPLOSION HAZARD: *Explosive gases and corrosive materials may be present. To prevent explosion or severe personal injury, installation technicians must be experienced with the safe installation of lead-acid type batteries.*

Before installing, commissioning, or performing maintenance, visit <https://www.fedsig.com/warning-mass-notifications-systems-tech-support> to download the ICM-DC RTU checklist.

Locating the Control Cabinet

First consider the siren location and method of activation before determining Control Cabinet location. You can activate the FCTBD unit remotely through radio or landline controls and locally using buttons provided in the Control Cabinet. See “Landline Siren Activation (optional)” on page 34.

Since the controls are in a NEMA 4 rated enclosure, you may install the controls indoors or outdoors.

To ensure proper siren power is maintained, it is recommended that the Control Cabinet location be within a 50 feet wire run to the siren. If it is necessary to make a longer run, use a 1 AWG or larger wire for the siren motor.

When mounting the Control Cabinet, it is recommended that the units be out of reach to avoid vandalism but accessible to service personnel. The Control Cabinet comes equipped with padlock hasps; use it for added security. Use corrosion-resistant lock assembly.

The Control Cabinet is shipped mounted on an aluminum channel with four mounting holes for 1/2-inch bolts. The total weight of the Control Cabinet is approximately 95 pounds; therefore, ensure that the mounting surface and fasteners can safely sustain the weight of the assembly and any additional environmental stresses placed on it.

See “Figure 4 Typical FCTBD Installation Example” on page 26.

NOTE: When installing this product, ensure that local and NEC guidelines are followed.

Figure 4 Typical FCTBD Installation Example

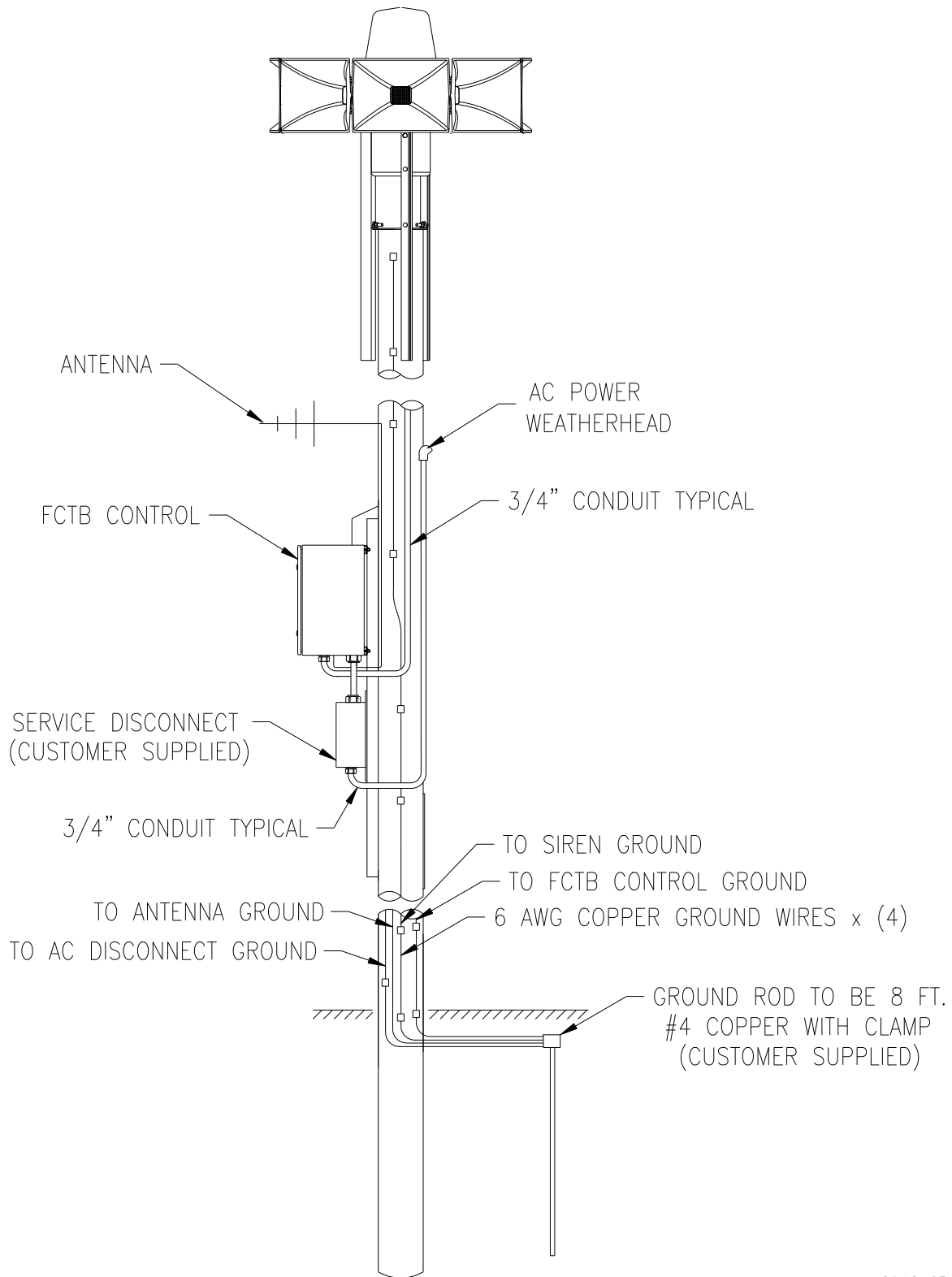

291246B

Installing the Control Cabinet

The Control Cabinet is attached to a length of four-inch channel. There are five pre-drilled holes in the channel:

- One 1-1/4-inch convenient lifting point
- Four 5/8-inch mounting holes

The total weight of the Control Cabinet is approximately 95 lb (43.09 kg). Therefore, it is imperative that the mounting surface and mounting method selected can safely sustain the weight of the assembly. In addition, the mounting method and surface used must be able to withstand external mechanical stresses that may be applied to the assembly.

The four 5/8-inch holes are for attaching the assembly to a wall or other substantial vertical surface. If the siren is installed on the roof of a building, it may be desirable to install the Control Cabinet inside the building if practical.

To install the Control Cabinet:

1. Prepare the mounting surface for hanging the assembly using the 5-inch channel as a template.
2. Attach the Control Cabinet to the wall, pole, or other substantial vertical surface using the four 5/8-inch mounting holes.

Electrical Connections

⚠ WARNING

Install the siren electrical system in compliance with local electrical codes and NEC recommendations. Federal Signal also recommends that all user-installed conduit connections enter from the bottom of the cabinet. Disconnect all power and read all warnings at the beginning of this manual and on the batteries before making connections.

⚠ CAUTION

The siren and control system must be solidly connected to an earth ground. If the siren is installed in a building, ground the system to a metallic object known to be grounded. For pole mount installations, drive a metal rod or bar at least eight feet into the ground, as close as practical to the base of the pole. Use a separate, continuous 6 AWG or larger wire from the siren frame to ground and from the cabinet of each siren control system to ground.

NOTICE

The FCTBD Unit requires 120 Vac power (or 240 Vac with the –240B option) to operate.

See “Figure 4 Typical FCTBD Installation Example” on page 26, “Figure 8 Single Motor Wiring” on page 57, and “Figure 9 T-Bolt Wiring” on page 58.

Connecting FCTBD to AC Power

To connect FCTBD to AC power:

1. Mount a service disconnect in close proximity to the Control Cabinet. Fuse the disconnect at 10 A (FRN 3). Ground the service disconnect to a driven earth ground. If one is not available, drive a 5/8 inch x 8 foot ground rod in close proximity of the pole or other mounting structure.
2. Route a section of pipe or liquid tight conduit between the Control Cabinet and the service disconnect of the siren, using one of the openings located on the bottom side of the Control Cabinet.
3. Determine the voltage to be used to operate the Control Cabinet.
 - For 120 Vac operation: Route one, 14-gauge black wire (HOT), one 14-gauge white wire (neutral), and one 14-gauge green wire, (chassis ground), from the service disconnect to the FCTBD and connect to F1, F2 and TB5 as shown in “Figure 8 Single Motor Wiring” on page 57. Set the AC voltage selection switch on the control board to 120 Vac.
 - For 240 Vac operation, use the –240B step-down transformer. Route two 14-gauge black wires (HOT) and one 14 gauge green wire (chassis ground) from the service disconnect to the FCTBD and connect to F1, F2 and TB5 as shown in “Figure 8 Single Motor Wiring” on page 57 (Detail A). Since the 240 Vac power is dropped in half by the –240B transformer, set the AC voltage selection switch on the control board to 120 Vac.

Connecting the Motor Starter (AC Contactor)

To connect the motor starter:

1. Install the Q-MOV kit per the instructions provided with the kit. Install one MOV across the coil of each contactor keeping the leads as short as possible.
2. The coil of the motor starter is controlled by the relay outputs at JP21 of the FCTBD control board. When the contact closes, it completes the circuit to supply AC power across the coil of the motor starter. The FCTBD output Relay #1 is at JP21 pins 1 and 2. This relay controls the “chopper” motor. T-bolt sirens may be controlled by a single contact closure from the FCTBD. If each motor starter is to be controlled individually by the FCTBD, relays 2 and 3 control the rotator and blower motors respectively. (See “Figure 9 T-Bolt Wiring” on page 58).
3. Run separate conduit from the Control Cabinet to the motor starter cabinet for making the motor starter connections.
4. Run a control wire (18 AWG minimum) for each contactor to be controlled from JP21 to the contactor coil. (See “Figure 8 Single Motor Wiring” on page 57 for single motor sirens and “Figure 9 T-Bolt Wiring” on page 58 for Thunderbolt sirens.)

Installing the Sensor

NOTICE

Verify the sensor package being used with the control system is compatible with the siren type it is being used to monitor.

See “Figure 9 T-Bolt Wiring” on page 58 for some sensor wiring configuration examples.

Sensor Models

The following sensor kits are available for sensing siren motor voltage(s) and current(s). Consult your Federal Signal sales representative for assistance to select the proper sensor kit for each installation.

Select the sensor that matches your siren motor type and number.

Table 12 Sensor kits options

Part Number	Description
SK-SM	Single motor AC current sensor
SK-3M	Three motor AC current sensor

Select the sensor that matches your voltage and phase.

Part Number	Description
SK1-120	Single phase, 120 Vac voltage sensor
SK1-240	Single phase, 240 Vac voltage sensor
SK3-240	3-phase, 240 Vac voltage sensor
SK3-480	3-phase, 480 Vac voltage sensor

CAUTION

To ensure proper and reliable two-way status monitoring, the operation and configuration of the sensors must be confirmed when the FCTBD is installed.

Installing the Motor Current Sensor

Motor configurations vary. Therefore, refer to the following instructions, which correspond to your sensor kit(s).

To install the motor current sensor:

1. Disconnect power to the siren and the siren control panel.
2. Secure the CURRENT SENSOR(S) inside the Control Cabinet with #10 machine screws and nuts. Repeat the installation for each motor current sensor to be installed.

NOTICE

The Control Cabinet is a NEMA 4 rated enclosure. Be sure to maintain the integrity of the enclosure.

Refer to the instructions provided with the current sensor. Route one of the motor power leads from the siren motor through the current sensor and terminate it to its motor contactor.

3. Route a piece of flexible, liquid-tight conduit between the siren's motor starter cabinet and the FCTBD.
4. Route the current sensor output lines from each current sensor, through the flexible conduit, into the FCTBD Controller Board at JP5 and JP10. Use the "Normally Open" contact from each sensor used. See "FCTBD Controller Board Indicators" on page 37.

Each current sensor has a pair of lines from it. When multiple sensors are used, identify each pair of current sensor lines. The current sensor lines terminate on the FCTBD control board JP5 and JP10. See "Figure 8 Single Motor Wiring" on page 57 and "Figure 9 T-Bolt Wiring" on page 58.

⚠ WARNING

SOUND HAZARD: The output sound level of a siren is capable of causing severe hearing damage. Therefore, always wear hearing protection when performing tests or maintenance on the siren.

Adjusting the AC Motor Current Sensor

To adjust the AC motor current sensor:

1. Turn on AC power to the siren and the siren control panel.
2. Using an AC ammeter, do the following: run, measure, and record the current of the motor(s) to be sensed to determine how many times the wire to be sensed must pass through the sensor.

NOTE: If the measured current is less than 1 A, pass the motor feed wire through the sensor more than once to multiply the current sense range. Example: If the current measured is 0.7 A, make two passes through the sensor to equal 1.4 A.

3. Activate the siren motor and turn the adjustment pot on the sensor until the sensor's LED just turns on. Verify the appropriate LEDs on the FCTBD turn on, D19 = Chopper, D20=Blower and D22=Rotator.
4. Turn off the motor and verify the LED on the current sensor turns off.

AC Voltage Sensors

Two different types of sensors are used for three phase and single phase sirens. See the appropriate section below for the type of voltage that will be monitored.

External AC Sensor 3 Phase: Models SK3-240 and SK3-480

To install the external AC sensor three phase:

1. Turn off AC power to the siren and control panel off at the service disconnect.
2. Connect the octal base terminals #3, #4, and #5 to L1, L2, and L3 for the siren motor power, respectively. A typical connection point is the load side of the disconnect or the line voltage input of the sirens control panel. See “Figure 8 Single Motor Wiring” on page 57 and “Figure 9 T-Bolt Wiring” on page 58.
3. Measure the line voltage at the service disconnects. Set the voltage knob on the voltage sensor 10% below the measured voltage. This adjustment sets the low voltage trip point.
4. Insert the voltage sensor into the octal base. Apply line voltage. The LED indicator lights and remains on. If the LED fails to light, a fault condition(s) exist and must be corrected. Switch any two connections on octal base terminals #3, #4, or #5 to correct phase reversal. A slight counterclockwise adjustment of the line voltage knob lowers the voltage trip point.
5. After the voltage sensor has been properly connected and the low voltage trip point has been adjusted, connect the output relay contacts (octal relay base terminals #1 and #8) and route the wires to the FCTBD Control Cabinet. Terminate the line from terminal #1 to JP10 pin 11 and terminal #8 to JP10 pin 12.

NOTE: The external AC sensor will not activate the AC power indicator (D20). To confirm proper operation of the external AC sensor requires communication with the Central Control Unit. Generate a report at the Central Control Unit and verify proper external AC sensor operation.

External AC Sensor Single Phase: Models SK1-120 and SK1-240

To install the external AC sensor single phase:

1. Turn off AC power to the siren and control panel at the service disconnect.
2. Secure the 1 Phase AC voltage sensor to the siren control cabinet using a #10 machine screw and nut.
3. Connect lines to the AC input of the voltage sensor and then route them to the line input voltage of the sirens control panel.
4. Measure the line voltage at the service disconnect. Set the voltage knob on the voltage sensor 10% below the measured voltage. This adjustment will set the low voltage trip point.
5. Connect lines to the output N.O. and COM. of the voltage sensor and route them to the FCTBD Controller Board. Terminate the N.O. line to JP10 pin 12 and COMM to JP10 pin 11 see “Figure 8 Single Motor Wiring” on page 57.

NOTE: The external AC sensor will not activate the AC power indicator (D20). To confirm proper operation of the external AC sensor requires communication with the Central Control Unit. Generate a report at the Central Control Unit and verify proper external AC sensor operation.

Installing the Antenna

⚠ WARNING

ELECTROCUTION HAZARD: To prevent electrocution or severe personal injury, install the antenna away from power lines and install it with proper grounding. Refer to section 810 of the National Electrical Code, ANSI/NAPA No. 70.

A factory installed, internally wired, antenna bulkhead adapter is provided on the top side of the Control Cabinet for ease of antenna cable interface. The bulkhead adapter requires the installation of a male N Type connector on the antenna cable for correct interface. It is essential that the installer follow all tuning (if applicable), installation, and safety instructions provided by the antenna manufacturer.

For installation instructions on the Yagi and Omni Antennas, go to the Federal Signal's website.

Pre-operational System Configuration and Testing

⚠ WARNING

SOUND HAZARD: The output sound level of a siren is capable of causing severe hearing discomfort or permanent hearing damage. Therefore, always wear adequate hearing protection and minimize exposure when performing any testing or maintenance on the siren.

⚠ WARNING

Failure to properly test the siren system before placing into service may prevent the siren from operating in an emergency. The following tests and calibrations must be performed by an experienced technician prior to using the siren system.

Configuring the FCTBD

Check that the FCTBD is properly programmed as defined in "Programming Software" on page 49 or according to the instructions provided with the programming software as applicable.

Testing the Sensors

To ensure proper and reliable two-way status operation, confirm that the sensors have been installed as instructed in "Installing the Sensor" on page 29.

Testing the Motor Current Sensor

Verify D19 on the FCTBD controller board turns on when the siren motor is on. D20 and D22 should also turn on with a Thunderbolt siren.

Testing the AC Voltage Sensor

Confirm that with the AC power source turned off (via service disconnect) the AC power indicator D24 is off. If using an external AC Power sensor, refer to the following instructions: External AC Sensor 3 Phase and External AC Sensor Single Phase.

External AC Sensor 3 Phase: Models SK3-240 and SK3-480

To verify the external AC sensor three phase:

1. Verify the octal base terminals #3, #4, and #5 to L1, L2, and L3 respectively. A typical connection point is the load side of the disconnect or the line voltage input of the sirens control panel. See “Figure 8 Single Motor Wiring” on page 57.
2. Measure the line voltage at the service disconnect. Set the voltage knob on the voltage sensor 10% below the measured voltage. This adjustment sets the low voltage trip point.
3. The LED indicator lights and remains ON. If the LED fails to light, a fault condition(s) exist and must be corrected. Switch any two connections on octal base terminals #3, #4, or #5 to correct phase reversal. A slight counterclockwise adjustment of the line voltage knob lowers the voltage trip point.
4. After the sensor has been properly connected and the low voltage trip point has been adjusted, verify contact closure, with AC voltage on, at the FCTBD, JP10 pin 1 to JP10 pin 2.

NOTE: The external AC sensor will not activate the AC power indicator (D24). To confirm proper operation of the external AC sensor requires communication with the Central Control Unit. Generate a report at the Central Control Unit and verify proper external AC sensor operation

External AC Sensor Single Phase: Models SK1-120 and SK1-240

To verify the external AC sensor single phase:

1. Verify the AC input to the voltage sensor.
2. Measure the line voltage at the service disconnect. Set the voltage knob on the voltage sensor 10% below the measured voltage. This adjustment sets the low voltage trip point.
3. After the sensor has been properly connected and the low voltage trip point has been adjusted, verify contact closure, with AC voltage on at the FCTBD, JP10 pin 1 to JP10 pin 2.

NOTE: The external AC sensor will not activate the AC power indicator (D24). To confirm proper operation of the external AC sensor requires communication with the Central Control Unit. Generate a report at the Central Control Unit and verify proper external AC sensor operation.

Verifying Intrusion Sensor

With the cabinet door open, verify that the intrusion indicator (D21) is on. Press the intrusion switch located on the cabinet door. With the switch pressed, confirm that the intrusion indicator is off.

Measuring the Battery Voltage

To measure the battery voltage:

1. Allow the battery to charge for 24 hours to ensure it is fully charged.
2. Turn off AC power to the power supply by disconnecting power at the service disconnect.

3. Using a digital multimeter (Fluke® model 75 or equivalent), measure the battery using the following test points (See “Chopper Motor Current Sensor” on page 21 for details.)

TB1-1 and TB1-4 = 13.8 Vdc*

Voltage reflects battery float voltage and may vary depending on the state of charge.

4. While monitoring the voltage, manually activate the intrusion switch and ensure the voltage does not drop below 11.5 Vdc while the radio is transmitting.

If a low battery condition is indicated, verify the charger output voltage is set to 13.5-13.8 Vdc without the battery connected. Repeat this measurement and replace the battery if it will not accept a charge.

5. Turn AC power on by turning on the service disconnect switch.

Measuring the 12 V Battery Charger

To measure charger output voltage, it must be disconnected from the battery since the battery's state of charge affects the voltage measurement. Use a digital multimeter to measure the charger output. Verify the charger output voltage is set to 13.5-13.8 Vdc.

Manual Siren Activation

Manually press each programmed function button and confirm correct siren operation. Refer to the controller programming and test data sheet (shipped with controller) for details.

Landline Siren Activation (optional)

Confirm that the user-supplied telephone control relay provides each appropriate remote function input with a momentary dry contact closure (1 second minimum) and observe proper siren activation. See “Control Board Power Input” on page 48 for details on interfacing and wiring.

Transceiver Interface, Alignment, and Siren Activation

Due to the test equipment requirements and RF control systems knowledge required to perform the following controller testing, only a qualified two-way Radio Service Technician should conduct the following test steps.

To ensure reliable radio control siren operation and proper decoding of the SS2000+ encoder/controller, the following testing must be conducted upon initial controller installation.

For the following steps, connect the Communications Service Monitor to the bulkhead connector mounted on the bottom side of the Control Cabinet.

Transmit Level Adjustments

NOTES:

- If CTCSS option is used, add 0.75 kHz of deviation of PL to the 3.0 kHz deviation level below.
- Deviation levels must be cut in half on 12.5 kHz narrowband channels.

To adjust the transmit level:

1. To transmit and generate a test tone, apply a jumper across JP15 on the FCTBD Controller Board (see “Figure 6 Transceiver Interface Connector P1” on page 45) or press the intrusion switch to generate a report.
2. Confirm the deviation level is at 3.0 kHz (DTMF) or 3 kHz for digital systems. This level has been pre-set at the factory; however, if adjustment is required, set R63 (DTMF) or R57 for digital systems on the controller board for a deviation level of 3.0 kHz (DTMF) or 3 kHz for digital systems. (See “Figure 6 Transceiver Interface Connector P1” on page 45.)
3. Using an Inline Watt Meter, confirm that the forward radiated power output matches the specified power output listed on the final test data sheet supplied with unit.
4. Using an Inline Watt Meter check for minimal reflected radiated power (10% maximum reflected power). If reflected power is excessive, check the antenna connections and refer to the antenna tuning instructions if applicable.

Adjusting the Receive Level

To adjust the receiver level:

1. Inject a 100 μ V carrier signal modulated with a 1 kHz tone at 3.0 kHz deviation for DTMF or for digital systems 1.5 kHz for narrow band channels.
2. Connect an oscilloscope to TP6 on the controller board and confirm a clean, undistorted sine wave of 1 V_{p-p} . The level has been pre-set at the factory; however, if adjustment is required, set R27 to 1 V_{p-p} for the external transceiver. (See “Figure 6 Transceiver Interface Connector P1” on page 45.) The level of the on-board receiver module is fixed and does not need to be adjusted.

Testing Controller Decode Sensitivity

To test the controller decode sensitivity:

1. With the DTMF transmit modulation level set to 3.0 kHz deviation or 1.5 kHz for narrow band channels.
2. Encode the appropriate DTMF strings required to enable the desired siren function. Confirm reliable decoding.

NOTE: If using FSK Digital System, press the button at the encoder.

Confirming Controller Auto-Reporting

By toggling one of the following asynchronous sensor inputs, confirm that the controller generates a properly formatted DTMF report string. See “DTMF Encoding Format” on page 48.

Operations

Intrusion

Press the intrusion switch and allow for one second for reporting, upon the release of the switch another report is generated.

AC Line Voltage

Remove AC power at the service disconnect. Confirm that a report is generated within five minutes that acknowledges loss of power. Restore AC power. Verify a report is generated acknowledging restoration of AC power.

Confirming Controller Responds to a Report Request

Poll the siren from the SS2000+ or the PC Control Point. Verify the siren responds with the correct site number and the correct status information.

Operations

System Operating Description

Siren Activation

The DTMF versions of FCTBD enable the user to program an ARM string into the controller for extra security. If an ARM string is not programmed, then an ARM command is not required to activate a function. Digital versions of FCTBs do not use the ARM function.

Activation Using the ARM function

To start siren activation through the radio, it is necessary to ARM the siren before initiating a siren function such as a wail or steady. Once the siren is ARMed, it remains ARMed for 255 seconds or 4.25 minutes unless a function is activated. Upon activation of the siren, the siren ARM timer stops until the function times out, is canceled, or is reset. The ARM command is not required prior to sending a RESET or REPORT command.

To start a function by either landline or button, it is necessary to provide a one-second closure on the landline or a one-second depression of the buttons.

Site Status Monitoring

To monitor or poll a site, request a report. The site does not need to be ARMed before requesting a report. Once a request has been made for a report, the FCTBD is able to report back its site status within a second if the channel is clear. If the channel is busy, the FCTBD is equipped with a carrier detect transmit hold off that causes the unit to wait until the channel is clear before the report is transmitted.

DTMF Only

The siren controller reports when polled from the SS2000+ or when one of its sensors changes state. The status of the site is encoded in a 9-digit DTMF string that is designed to work with a Federal Signal SS2000+ to decode, format, and time and date stamp the received string. For detailed information about the DTMF coding format, see "Chopper Motor Current Sensor" on page 21.

Automatic Reports

The FCTBD automatically sends back a report if one of the following sensors has a change of state: AC, Low Battery, Intrusion, Stuck Relay detected, Motor Fuse fail, or the siren is activated locally. The control station can also be set to automatically poll the system at a predefined interval. Automatic reporting may be optionally disabled on FCTBD systems. The FCTBD is equipped with a carrier detect transmit hold off that causes the unit to wait until the channel is clear before an automatic report is transmitted.

The thresholds are in the following table.

Table 13 Thresholds

Input	Threshold	Time
AC fail internal	57 Vac +/- 5%	57 sec +/- 1
AC fail external TR	40 V _{RMS} +/- 1%	2.2 sec + 1 sec x site #
Battery 12 V	12.7 V +/- 3%	20 sec
Battery 48 V	43.5 V +/- 3%	20 sec
Intrusion	Door Open	555 ms
Stuck Relay Detect	relays off & current = 50 300 A	222 ms
Motor fuse	1.0-3.4 V	5 sec
Local Activation	Button	10 sec

Growl Test

The Standard Growl Test runs the rotator for 12 seconds (if applicable) and the chopper motor until the sensors latch or a maximum of 2 seconds. This function is commonly used when doing periodic testing to verify proper operation while generating minimal sound.

FCTBD Controller Board Indicators

The following table provides a description of LED indicators on the FCTBD Controller Board.

Table 14 FCTBD Controller Board Indicators

Component Number	Description	Indication
D25	CPU LED	Microprocessor Heartbeat
D12	RECEIVE LED	RF Carrier Indicator on with carrier
D18	TRANSMIT LED	Transmit
D60	RELAYS ARMED	Power to relays on
D62	RELAY #1 LED	Relay #1 closed
D63	RELAY #2 LED	Relay #2 closed
D65	RELAY #3 LED	Relay #3 closed
D66	RELAY #4 LED	Relay #4 closed, or PA mode
D20	PRESSURE LED	Pressure Sensor input
D21	INTRUSION LED	Intrusion Sensor input
D19	CURRENT LED	Current Sensor input
D22	ROTATION LED	Rotation Sensor input
D23	LOW BATTERY LED	Low Battery Sensor (internal)
D24	AC POWER FAIL LED	AC Power Fail Sensor (internal)

D26	POWER LED	+5 V Operating Power
D79	ISO +12 V	Isolated 12 V power
D77	ISO +5 V	Isolated 5 V power
U18	LCD Display	Displays Function Counters, Decodes and Software Revision

The following tables provide descriptions of the FC Controller Board connectors, selections, and switches.

JP1	<p>SINAD</p> <p>1 Receiver module carrier detect, short to pin 2 when using SINAD board along with both sides of JP4</p> <p>2 External transceiver carrier detect</p>
JP2	<p>Test Speaker</p> <p>1 0 to 2 V_{p-p} Audio Source: Receiver Audio during P.A. functions, Siren Audio during Electronic Siren functions</p> <p>2 Ground</p>
JP3	<p>Short For VOX Carrier Detect</p> <p>Short pins 1 and 2 for VOX carrier detect</p>
JP4	<p>Test Speaker</p> <p>1 VCC, +5 V</p> <p>2 VCC, +5 V</p> <p>3 Short pins 1 and 3 to give priority to the external transceiver</p> <p>4 Short pins 2 and 4 to give priority to the internal receiver. With no shorting jumper, first carrier detect has priority. Short both sides when using SINAD board along with JP1.</p>
JP5	<p>Sensor Inputs (#1 at left edge)</p> <p>1 Pressure sensor input, dry Contact closure < 1 K</p> <p>2 ISO Ground</p> <p>3 Intrusion sensor input, dry Contact closure < 1 K</p> <p>4 ISO Ground</p> <p>5 Current sensor input, dry Contact closure < 1 K</p> <p>6 ISO Ground</p> <p>7 Rotation sensor input, dry Contact closure < 1 K</p> <p>8 ISO Ground</p> <p>9 48-Volt Battery input to 48-Volt sensor and to power supply, 15–75 Vdc</p> <p>10 Ground</p> <p>11 12 Volt Battery input to 12 Volt sensor and to power supply, 11–15 Vdc</p>
JP6	<p>Speaker Mute gate bypass</p> <p>Short pins 1 and 2 to bypass speaker mute gate, allow monitoring of radio channel with local speaker</p>
JP7	Receiver Module for one-way receiver
JP8	Serial and FLASH programming Port
JP9	LEDs on with Intrusion

JP10	Remote Activation and Sensor Inputs (#1 at left edge of connector)	
	1	Spare Sensor Input #2, dry Contact closure < 1 K
	2	ISO Ground
	3	Spare Sensor Input #1, dry Contact closure < 1 K
	4	ISO Ground
	5	Remote Activation Input #4, Activates Functions under code 4, dry Contact closure < 1 K
	6	ISO Ground
	7	Remote Activation Input #3, Activates Functions under code 3, dry Contact closure < 1 K
	8	ISO Ground
	9	Remote Activation Input #2, Activates Functions under code 2, dry Contact closure < 1 K
	10	ISO Ground
	11	Remote Activation Input #1, Activates Functions under code 1, dry Contact closure < 1 K
12	ISO Ground	
JP11	Used for special applications	
	1 and 2	See Options for JP11
	3-8	Not used
	9 and 10	See Jumper pins 9 and 10 (Normally Jumpered)

Options for JP11

Jumper pins 1 and 2

Table 15 2001 DC Solar mode

AC (Power)	AC power and external power or 50 Vdc (AC power or 48 V battery/charger) latching
Battery	>12.7 V (DC-DC) and > 43.7 V (48 V battery)
Pressure	Motor fuse (low = pass)

Table 16 2001 DC Non-Solar mode

AC (Power)	AC power and external AC power (not looking at 48 Vdc)
Battery	>12.7 V (DC-DC) and > 43.7 V (48 V battery) (either 12 or 48 fail will cause a fail) Transfer switch low voltage detect (External AC input Sense2, low=voltage pass)
Pressure	Motor fuse (low = pass)

Table 17 FCD Repeater Solar mode

AC (Power)	AC power and external power or 50 Vdc (AC power or 48 V battery/Charger) latching
Battery	12.7 Vdc (connects to 12 V battery or DC-DC convertor)
Pressure	Charger = External charger sense contact (low = pass)

Table 18 FCD Repeater Non-Solar mode

AC (Power)	AC and external power or 50 Vdc (AC power or 48 V battery/charger) latching
Battery	12.7 Vdc (connects to 12 V battery or DC-DC convertor)
Pressure	Charger = External charger sense contact (low = pass)

Jumper pins 9 and 10 for NXDN Mode or Transformer Rectifier and Control Mode

NXDN Mode

When the NXDN mode is polled, the system responds over the port which received the poll request only.

Transformer Rectifier and Control Mode

Use relay number 3 to switch from Transformer Rectifier (TR) to batteries in order to conduct a battery test. Remote AC power sense debounce fixed at 4 seconds (normally 28 seconds).

Standby:

- If low voltage occurs, JP10 on pins 11 and 12 get an open contact from the TR contactor.
- If the voltage is normal, TR gives a contact closure across JP10 on pins 11 and 12.

JP12	SINAD 1 Directly to processor pin #58 (ADC7) 2 Ground
JP13	CTCSS Encoder/Decoder 1 Receive audio, not DC isolated, set to 1 V _{p-p} with 1 kHz tone at 3 kHz deviation for wideband 1.5 kHz deviation for narrowband 2 Ground 3 +8 Vdc, < 100 mA current 4 Decode not & PTT line, low with decode, set low by processor during transmit 5 Transmit audio, 0 to 2 V _{p-p} of Digital data or Tone
JP14	Force Carrier Detect 1 Short to (JP14, pin 2), to force carrier detect on 2 Ground
JP15	Short To Set Deviation 1 Short to ISO Ground (JP15, pin 2), causes unit to transmit for setting deviation 2 ISO Ground
JP16	Aux Serial Port 1 2 TXD, standard RS232 levels 3 RXD, standard RS232 levels 4 Ground 5 CTS 6 RTS

JP21	Relay Outputs, 3 A, up to 240 Vac, (#1 at left edge of connector) 1 Relay 1, Common 2 Relay 1, N.O 3 Relay 2, Common 4 Relay 2, N.O 5 Relay 3, Common 6 Relay 3, N.O. or N.C., depending on jumper JU1 7 Relay 4, Common 8 Relay 4, N.O. or N.C., depending on jumper JU2
JP22	AC Power Input 1 and 2 120 or 240 Vac +/- 10%, 60 Hz (Set S7)
JP23	TR Sensor Input 1 Ground 2 TR voltage input, 0-50 Vdc, 0-79.4 Vp full wave rectified AC
JP24	Charger Disable Output 1 Isolated Emitter, pulls to isolated Ground to disable 2 Isolated Open Collector
JP25	Charger Status Input 1 Isolated active low input, pulls to isolated Ground when status is OK 2 Isolated Ground
JP26	Relay Output #3 Arm Select Jumper pins 1 and 2, no Arm required (not need a function activated to run) Jumper pins 2 and 3, requires Arm (a function must be activated) to work
JP27	Digital Receive Disable Jumper pins 1 and 2 to disable receiving AFSK digital signals
JP28	Relay Output #3 Arm Select Jumper pins 1 and 2, no Arm required (not need a function activated to run) Jumper pins 2 and 3, requires Arm (a function must be activated) to work
JP29	Fast DTMF Decode Jumper pins 1 and 2 to enable decoding of fast DTMF
JP30	Option header Jumper pins 1 and 2 to enable option #1 Jumper pins 3 and 4 to enable option #2 Jumper pins 5 and 6 to enable option #3 Jumper pins 7 and 8 to enable option #4
JP31	Disable Transmit Time-Out-Timer Jumper pins 1 and 2 to disable transmit time-out-timer
JP32	I ² C Port 1 +5 V 2 SDA / SCL 3 SCL / SDA 4 INT input, active low 5 Ground 6 Ground

Operations

P1	Transceiver Interface
	1 Transmit audio, DC isolated, 0 to 1 V _{P-P}
	2 Receive audio, DC isolated, 350 mV _{P-P} to 3 V _{P-P}
	3 PTT not, goes low (<0.65 V) during transmit
	4 Ground
	5 +12 Vdc, 100 mA max, 2 A with battery
	6 Carrier Detect not, set low (< 0.65 V) during receive
	7 No connection
	8 Ground
9 Ground	

TP1	Two-Tone Decoder, HighPass Filter Enable Goes high when processor is decoding a tone > 2100 Hz
TP2	Two-Tone Decoder, LowPass Filter Enable Goes high when processor is decoding a tone < 400 Hz
TP3	Receive audio to Two-Tone Decoder Audio at last stage before two-tone comparator, 1 to 3 V _{P-P}
TP4	Transmit audio 0.1 to 3 V _{P-P}
TP5	Receive audio from Two-Tone Decoder to processor Audio after two-tone comparator, square waves to processor, 0 to 5 V _{P-P}
TP6	Receive audio level set External transceiver receive audio set to 1 V _{P-P} using R27
TP7	RX Data Receive data from digital modem IC, 0 to 5 volts
TP8	DTMF Decoder STD Goes low whenever a DTMF digit is being decoded
TP9	Voltage at 48 volt Battery Input 0-70 Vdc = 0-5 Vdc
TP10	Voltage at 12 volt Battery Input 0-20 Vdc = 0-5 Vdc
TP11	Ground
TP12	5 V, +/-2% Regulated power supply
TP13	2.5 V, +/-2%, Regulated reference supply
TP14	3.3 V, +/-5%, Regulated power supply
TP15	TR sense input, 0-50 Vdc or 0-79 Vp (full wave rectified AC) = 0-5 Vdc
TP16	Incoming unregulated 17 volt power supply, 14.4-75 Vdc
TP17	8 V, +/-5%, Regulated power supply
TP18	12 V, +/-10%, Regulated power supply
TP19	Isolated Ground
TP20	Isolated +12 V, +/-10%, Regulated power supply
TP21	Isolated +5 V, +/-10%, Regulated power supply

Switches

Switches provide the following: local activation via on-board button, master reset, site address, and AC voltage selection.

S1	Local Activation #4 Press and hold for 1/2 second, Activates Functions under code 4
S2	Local Activation #2 Press and hold for 1/2 second, Activates Functions under code 2
S3	Local Activation #3 Press and hold for 1/2 second, Activates Functions under code 3
S4	Site Address Switch Sets units site number
S5	Processor Reset
S6	Local Activation #1 Press and hold for 1/2 second, Activates Functions under code 1
S7	120/240 Vac Selector switch

Speaker Output

R27	External transceiver receive audio set to 1 V _{P-P} at TP6
R76	Test Speaker output level set
R58	MSK modem transmit deviation level set
R63	DTMF transmit deviation level set

Assigning Site Address (S4)

The site address switch gives each controller in a two-way system its unique unit number.

For use with Commander: In order for the siren to report back with its identity, define the site address by setting DIP switches located on the board. The DIP switches have values of 1, 2, 4, 8, 16, 32, 64, 128, 256, 512. Add appropriate DIP switch values to define the site number address.

Example

To define the board for Site #1, toggle the first DIP switch to the left. All other DIP switches are to the right. For Site #2, toggle the second DIP switch to the left. For Site #3, toggle the first and second DIP switch to the left. For Site #4, toggle the third DIP switch to the left. For Site #5, toggle the first and third DIP switch to the left. Continue this method to define other site number addresses.

Figure 5 Setting the Switch Number Example

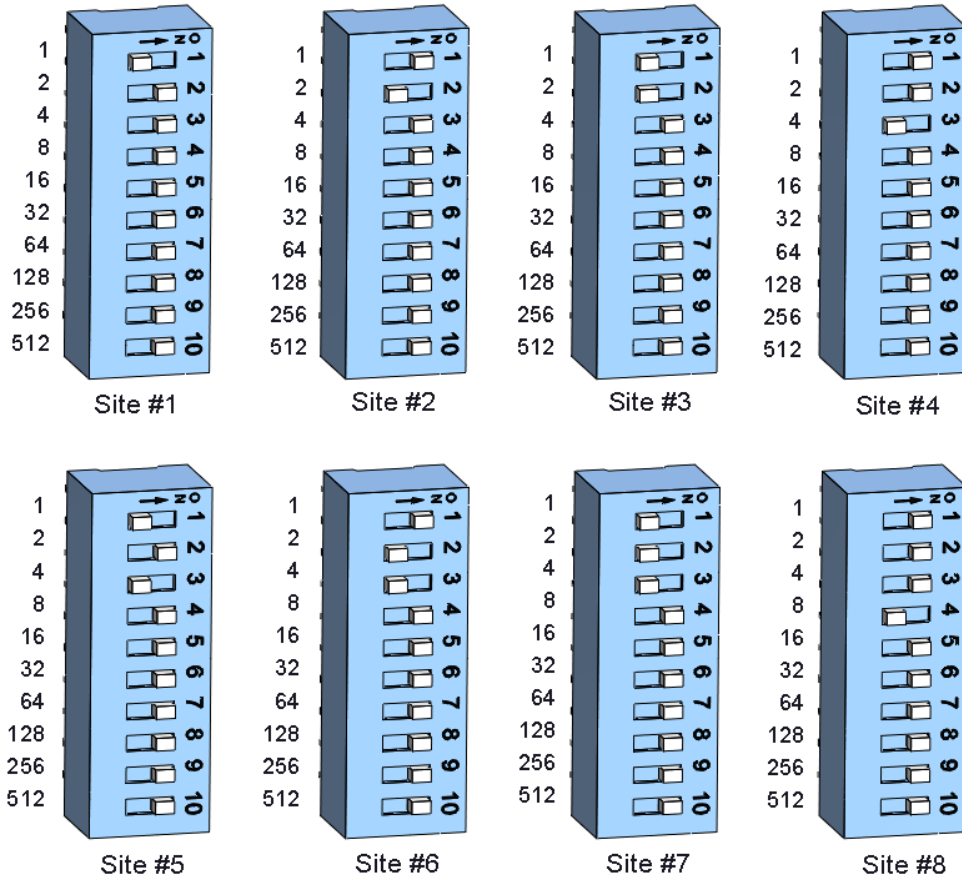

Switch number	1	2	3	4	5	6	7	8	9	10
Binary number	1	2	4	8	16	32	64	128	256	512

Example: Switch numbers 1, 2, and 3 are binary numbers 1, 2, and 4.

Add 1 + 2 + 4 = 7; 7 is the unit address

NOTES:

- Set the site address to one to program the controller card with firmware (HEX code).
- To program a non-digital unit using FSPWARE Software, set the site address to one. When programming is completed, change the DIP switch setting to the actual site address.
- The site address is stored at power up of the controller. If the site address is changed, cycle all power to the card (battery and AC).

Transceiver Interface

You can interface a transceiver through the male DB9 connector P1.

P1	Description
1	Transmit Audio
2	Receive Audio
3	PTT (active low)
4	Ground
5	12 Vdc (unregulated)
6	Carrier Detect
7	Not used
8 and 9	Ground

Figure 6 Transceiver Interface Connector P1

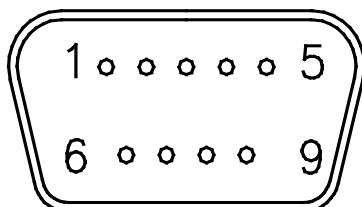

Transmit Audio

You can adjust the encoded audio from 0 to 1.2 V_{p-p} (O.C.) using the DTMF Deviation Potentiometer, R63 and Digital Deviation Potentiometer, R58. Use it to set the audio output level to the transceiver. You can connect the transmit audio to the radio's line level (flat) audio input or its mic (pre-emphasized) audio input, but the flat or non-pre-emphasized input is preferred and is easier to adjust. The transmit deviation is adjusted as follows:

- DTMF—Adjust R63 for 1.5 kHz deviation (add 0.35 kHz deviation if CTCSS is used)
- Digital—Adjust R58 for 1.5 kHz deviation (do not exceed 2 kHz)

***NOTE:** Set the deviation to 3.0 kHz and CTCSS level to 0.75 kHz on 25 kHz spaced channels.

The transmit audio is generated by U14 (the DTMF encoder), U12 (the digital encoder), and the CTCSS board (if present). PTT is generated by the processor taking pin 44 low. This gates U11:B on, allowing the transmit audio to pass out to the transmitter.

The PTT also sets the collector of Q4 high, which allows R47 to turn on Q3 through R44. Q4 pulls the PTT line low and activates TRANSMIT LED D18. The collector of Q4, being high, also allows R48 to begin charging C15. When this exceeds 5 volts, U3A forces its output to ground and shuts off Q3. This provides a timeout timer to prevent the transmitter from getting stuck in transmit.

The PTT signal also sets the output of U17F high, turning on Q5. This sends a ground to the CTCSS board, telling it to encode rather than decode.

Operations

Receive Audio

Connect the receive audio to the radio's de-emphasized audio out. You can adjust the audio level by R27 to 1 V_{p-p} at TP6 when receiving a properly modulated signal as described above.

PTT

Push-to-talk pulls to ground to place the transceiver into transmit mode.

+12 Vdc

The +12 Vdc is an unregulated, 1.0 A supply that can vary from 11.5 to 13.6 Vdc.

Carrier Detect

Carrier Detect input requires a pull to ground to indicate when carrier is present.

Sensors and Sensor Inputs

The FCTBD Controller Board comes with the following inputs to work with external sensors and two built-in sensors to report the following conditions.

AC	JP22
AC (External Sensor Input)	JP10-1
Low Battery, 12 Vdc	JP5-11
Low Battery, 48 Vdc	JP5-9 (only used with 48 V type sirens)
Rotation (Proximity Switch)	JP5-7
Rotation (Current Sensor)	JP10-3
Main Siren Motor Current	JP5-5
Intrusion	JP5-3

AC Sensor

During normal operation (when AC is present) the built-in AC sensor does not light. If AC is lost, the AC LED lights. The AC sensing logic is dependent on both the built-in AC sense and the external AC sense points. If an AC loss is detected at either point, a report is sent. A loss of AC is not reported immediately. The controller makes sure the loss lasts at least 2 seconds, and then it adds (1 second * Site #) before reporting. Each siren with an AC failure reports by site number in sequential order with a two-second delay between sites. Once AC is restored, another automatic report is sent in the same order to show change of state. If AC is restored before the automatic report is sent, the report is canceled.

Low Battery Sensor

The low battery sensor input measures the voltage across the 12 V battery. If the battery voltage goes below ~12.5 V for 20 seconds, the controller reports a low battery condition. The controller does not automatically report when the battery voltage returns to normal to eliminate the possibility of multiple reports when a battery is very weak. The low battery condition remains latched in memory until the controller is reset or a function is run and the battery voltage is restored.

Digital Inputs for Rotation Sensor

There are two rotation sensor inputs. Depending on the sensor option purchased, either the current sensor or proximity switch input is used.

- Standard Rotation Sensor Input: JP10-3 is used for the rotation motor current sensor. This input latches when current is detected. During a siren rotation this input is pulled low. The latch is reset by the RESET command.
- Proximity Switch Rotation Sensor Input: JP5-7 is used to connect a proximity switch to detect siren rotation. You may leave this input unconnected if a non-rotating siren is used or if JP10-10 is used to detect rotation. During a normal siren activation (when the siren is rotating), the external rotation sensor, which is usually an open collector proximity device mounted in the siren to detect gear movement, provides active low pulses. Once this input receives more than 11 low pulses during a siren activation, this input will latch active until a reset command is received.

Digital Input for Current Sensor

Use JP5-5 to detect the main siren motor operating current during siren activation. This input is pulled low when the external current sensor detects proper running current during a siren activation. If this input is pulled low for 1/4 second, the input is latched active until another activation command is received or a Reset command is sent.

Digital Input for Intrusion Sensor

Use JP5-3 to detect an intrusion into the Control Cabinet. With the Control Cabinet closed, the intrusion switch is in a normally closed position. If the intrusion condition changes state for more than one second, an auto-report is sent.

Digital Input for Pressure Sensor (not used with 2001-130 sirens)

Use JP5-1 to detect blower pressure on sirens during siren activation. This sensor input latches when operating current is detected (input is pulled low) and resets when a RESET command is received.

Relay Outputs

There are four relay outputs on the FCTBD Controller Board, which are controlled by the microprocessor. The relays provide isolation and are spike protected to prevent voltage spikes from affecting the unit. As the relay coil is energized, the outputs close, and the associated LED lights. The FCTBD Controller Board comes standard with two usable relays. Relay #3 is wired as a normally closed contact. Relay #4 is reserved for the radio low voltage cutoff feature. A jumper placed on JP20 keeps relay #4 closed until the FCTBD reaches a low voltage cutoff limit. Upon cutoff, relay #4 opens, preventing the radio from completely discharging the battery. See JP21 in the Functional Description section.

Speaker Output

You can use the speaker output at JP2 to monitor received audio, route remote P.A. or provide signal out when the tone generator option is used. You can adjust speaker output up to 2.0 V_{p-p} into an 8-ohm load using R76.

Monitor Received Audio

When the carrier is present, the received audio is routed to the test speaker output at JP2.

Remote Public Address

You need to program the P.A. as a function through the software if it is to be used. When the P.A. function is activated, the FCTBD Controller Board routes the received audio to the speaker output as long as the carrier is detected. If the carrier drops out for more than 15 seconds, the unit goes back to standby mode.

Audio Function Generator Option

To use this feature, you need to program one of the standard signals or a custom signal through the software. When the audio function is activated, the audio from the function generator is routed to the speaker output until the function finishes or a cancel code is sent.

Landline and Local Button Activation

Shorting any one of these pins to the isolated ground activates the function associated with it. The inputs are protected by limiting diodes and optical-isolator IC U26. There is also a button on the board for each of these functions that activates the associated input. See JP10 in the Functional Description section.

Control Board Power Input

The FCTBD Controller Board has a switch selectable nominal 120/240 Vac power input. When the proper voltage is applied, the POWER LED is lit. Set S7 to the appropriate voltage input level. Verify the charger is also set accordingly. See “Installation” on page 25 for installation details.

FCTBD Decoding and Encoding Formats

Decoding Formats

DTMF

Receive audio enters the DTMF decoder IC (U14) from the high pass filter through C51 and R64. When a proper DTMF digit is being decoded, TP8 will go low and a binary output will appear on pins 18, 19, 20, and 20 of U14.

Two-Tone

The FC Controller Board decodes two-tone codes with tone accuracy within 1.5%. Timing must be at least 80% of what has been programmed. The inter-tone gap must be less than 400 milliseconds. The recommended minimum tone spacing is 5%. You can use tone timings between 0.5 seconds and 8 seconds for the A tone and between 0.25 seconds and 8 seconds for the B tone.

DTMF Encoding Format

The FCTBD Controller Board encodes a nine-digit DTMF string that includes the RTU's unit type, ID number, function status, and sensors status. See “Chopper Motor Current Sensor” on page 21 for detailed information.

Programming Software

FSPWARE

FSPWARE is software for two-tone and DTMF controlled systems. This software requires a direct connection between the siren and the computer's RS232 port through the use of a PCB universal cable adapter.

Commander Software (SFCDWARE)

Commander® Software (SFCDWARE) is used to control, monitor, and configure the siren controller. The software communicates with the siren controller over an RS232 port. Refer to the Help menu provided with the software for operational details.

Service and Maintenance

⚠ WARNING

MOVING PARTS HAZARD: The siren has moving parts, high operating current, explosive gases, corrosive materials, and high output sound levels, which could cause severe personal injury, electrocution, or death.

Qualified personnel familiar with the siren, associated controls, and power sources being used should perform service or maintenance.

Before servicing or maintaining, ensure that remote activation cannot occur and disconnect power to the siren and the associated control equipment.

For information about recommended cables for the radio, refer to Recommended Cables for Radio sheet (SYS5060) on www.fedsig.com.

Preventative Maintenance

To ensure that the warning system is fully operational and to maintain the highest possible level of reliability, perform the following monthly testing and annual inspection. In order to maintain the integrity of the warning system, prompt investigation of any reported failures must be researched and corrected promptly.

Monthly Testing

The following is a typical monthly test outline:

1. Reset all sirens to clear latched sensor status inputs (DTMF systems only).
2. Activate one of the siren functions (3-minute activation recommended).
3. Poll the system for siren status reports.
4. Examine each site report for any failed condition. If you detect a failure condition, notify designated service personnel.

Annual Inspection

Perform the pre-operational system test procedure on an annual basis. See "Pre-operational System Configuration and Testing" on page 32 for details.

Options

Model -240B

Model -240B allows the Control Cabinet's battery charger to operate when only 240 Vac power is available. The unit provides a 120 Vac output.

FS-SINAD Option

The SINAD Meter board is a small add-on board option that plugs into the siren controller. This gives the user the ability to measure the quality of the received RF signal reaching a Remote Terminal Unit (RTU). This option is only available on the SFCDWARE two-way communication system (SFCDWARE version 7_22 and later). The SFCDWARE system indicates the SINAD of the RTU through the selection of the SINAD test. See SFCDWARE help file for details. This enables the ability to track changes, which may indicate a degradation or failure in the receiving system. The on-board display also provides personnel in the field a way to visually confirm the quality of the received signal.

The truest measure of a decoder's ability to perform its function is the ratio of signal to noise and distortion arriving at the decoder. The received audio, which the decoder must decode, contains the intended signal plus any noise and distortion. Many things can cause noise and distortion, such as low transmitter power, terrain or weather conditions, a malfunctioning receiver or its antenna, or even other nearby transmitters. The fact that this measure of signal-to-noise and distortion ratio encompasses any and all things, which have affected the received audio, makes it a valuable measure for predicting the decoder's ability to do its job.

This board measures the SINAD of a received 1200 Hz signal. The measured SINAD is passed to the processor of the FCM and also displayed on 10 LEDs on the SINAD Meter board. When the lowest LED lights, the SINAD is 3 dB and each successive LED is another 3 dB, up to 30 dB SINAD. Acceptable SINAD is 18 dB.

Features:

- SFCDWARE software indication of RTU SINAD
- Accuracy to +/- 1 dB
- Visual Display in 3 dB steps from 3 dB SINAD to 30 dB SINAD
- Easy installation on existing controllers

Model FCTBD-IP

The FCTBD-IP combines the characteristics of an FCTBD with serial-to-Ethernet conversion capabilities. This allows serial devices to communicate over an Ethernet network and provides audio decoding of digitized audio sent over the network.

The converter is configured with its own fixed IP address and port number. When packets of data are received over the Ethernet port that are addressed to the board's IP and port number, they are converted to serial data and sent out over the serial port. Likewise, any data coming into the serial port is converted to TCP/IP data packets and sent out over the Ethernet port to the server's IP address. The unit also contains a digital-to-analog converter. This allows specially configured incoming data packets to be converted to audio, which is then filtered and sent out over a 600-ohm audio port.

Ethernet Board Specifications

Table 19 Ethernet Board Specifications

Electrical	
Input Voltage	10.5 to 95 Vdc
Current Draw	< 150 mA
Serial Port	
Serial Port Protocol	RS232C, N, 8, 1 baud rate configurable
Ethernet Port	
Protocol	IEEE 802.3, 10 Base-T connection
600 Ohm Audio Output Port	
Protection	MOV and Transorb surge protection
Impedance	600 ohms
Audio Output Level	Adjustable from 0.30 to 3.00 V _{P-P} (-17 dB to +2.7 dB) into 600 ohms
Environmental	
Operating Temperature	-30°C to +65°C
Humidity	0 to 95% non-condensing
Physical	
Dimensions (H x W x D)	~ 2 x 4 x 6.5 inches
Weight	< 2 lb

Connections

Table 20 Connectors

JP1	600-ohm Audio Output Port Balanced line output.
JP2	JTAG Emulation port
JP3	Audio Output Expanded or Flat Selection Jumper Jumpers pins 1 and 2 for flat audio output. Jumpers pins 2 and 3 for expanded dynamic range audio output.
JP4	RS232 Serial Port 3 Ground, 0.5 A maximum current capacity 4 Radio transmit data from PC, standard RS232 levels 5 Radio receive data to PC, standard RS232 levels 6 Ground, 0.5 A maximum current capacity
JP5	FLASH Programming and Converter Configuration Port 2 TX Data, standard RS232 levels 3 RX Data, standard RS232 levels 4 Ground 5 Serial Clock input for FLASH programming, standard RS232 levels 6 Processor Reset Not line, used in programming FLASH, 10 K pull-up
JP6	10.5-95 Vdc Power Input 1 - (-) 2 - (+)
JP7	Resets board back to factory default settings

J1	Ethernet Network Port 1 & 2 Transmit data pair, balanced line 3 & 6 Receive data pair, balanced line 4, 5, 7, 8 AC coupled ground
----	--

Table 21 Indicators

D1	CPU Heartbeat indicator, green.
D2	Transmit data indicator, red.
D3	Receive data indicator, yellow.
D4	Power indicator, green.

Table 22 Controls

R1	600 ohm audio output level set.
----	---------------------------------

Figure 7 Serial to Ethernet Board

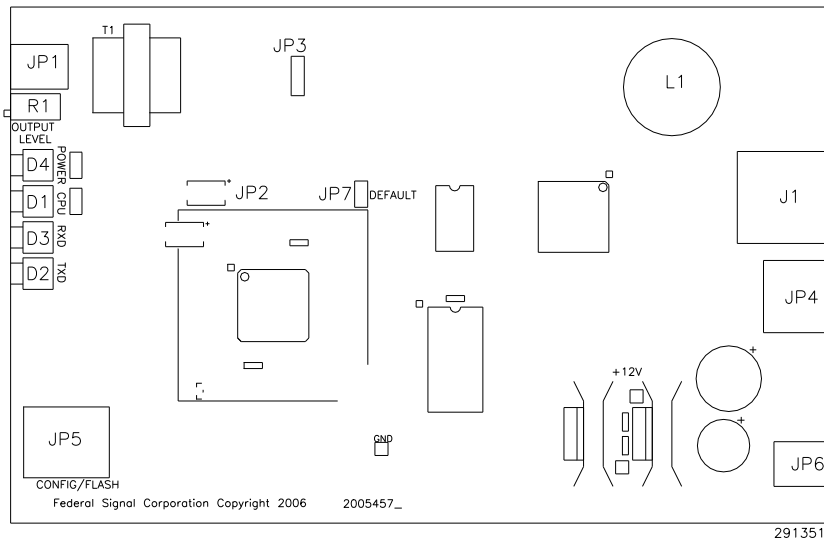

Network Information

Protocols Supported

- TCP/IP
- UDP (optional)
- XML (optional)
- XMPP (optional)

IP Ports Used

- 16887 (SmartMsg TCP/IP)
- 80 (HTTP)
- 3100 (optional UDP Serial Over IP)
- 3101 (optional UDP Voice Over IP)

IP Address

User selectable

TOS/DSCP (Type of Service)

User selectable

Bandwidth Requirements

Voice Over IP	150 K baud per connection
Siren Activation	50 bytes per connection
Siren Poll Response	74 bytes per connection

Power Supply and 13.8 V Battery Charger

The mechanical siren power supply and charger allows the siren controller and a two-way radio to be powered from AC or from a backup battery. It also keeps the battery charged. The 13.8 V power supply can deliver up to 10 A of current, and the charger delivers a current limited 13.75 V float charge.

Features:

- Powered from 102-132 Vac or 204-264 Vac
- 13.8 V, 10 A regulated and current limited output
- 13.75 V, 1 A regulated and current limited charge output

Table 23 Specifications

Electrical	
Input Voltage	102-132 Vac or 204-264 Vac, 120 and 240 Vac nominal
Power Supply Output Voltage	13.8 Vdc +/- 5% for 120 Vac +/-10% +5 /-10% for 120 Vac +10 /-15%
Power Supply Output Current	10 A max
Battery Charger Output Voltage	13.75 Vdc +/- 2%
Battery Charger Output Current	1 A Current Limited
Environmental	
Operating Temperature	-30° to +65°C (-22° to 149°F)
Humidity	0-98% Non-Condensing
Physical	
Size	6.50 x 9.23 inches
Weight	6 lb

Table 24 Connectors

JP1	AC Power Output to transformer primary 1 High side of first transformer primary 2 Low side of first transformer primary 3 No connection 4 High side of second transformer primary 5 Low side of second transformer primary
-----	---

JP2	AC Power Input from transformer secondary 1 High side of first transformer secondary 2 Low side of first transformer secondary 3 High side of second transformer secondary 4 Low side of second transformer secondary
JP3	AC Power Input 1 L1/Hot 2 L2/Neutral 3 Earth Ground
JP4	Power Output to Radio 1 Ground 2 +13.5 Vdc
JP6	Charger Output to Battery 1 Ground 2 +13.5 Vdc

Table 25 Test Points

TP1	Rectified AC power from transformer, 16-25 Vdc
TP2	Output of 13.86 V regulator, 13.86 Vdc, +/- 4%.
TP3	Output of Battery Charger regulator, 13.75 Vdc, +/- 2%
TP4	Ground
TP5	Output of 5 volt reference, 5.00 Vdc, +/- 0.2%

Table 26 Indicators

D1	Power, 13.8 V power supply on
D4	Charging, On when battery voltage is less than 13.3 V
D7	Ready, On when battery voltage is greater than 13.3 V

Testing the Power Supply and Charger

To test the power supply and charger:

1. Set the AC voltage selection switch, S1 to 115 and power the unit with 120 Vac.
2. Confirm that there is 13.36-14.36 V on TP2.
3. Connect a 1.3 Ω , 1% resistive load across JP4.
 - Confirm that the output voltage is \approx 13Vdc.
 - Disconnect the 1.3 Ω load.
4. Confirm that there is 4.9925-5.0075 V on TP5.
5. Confirm that there is 13.47-14.03 V across TP3.
6. Confirm that the Ready LED is on.
7. Connect an 8 Ω , 1% resistive load in series with an Ammeter across JP6.
 - Confirm that there is at least 1 A of current.
 - Confirm that the Charging LED is on.
 - Disconnect the 8 Ω load.

Replacement Parts

To order replacement parts, call Customer Support. See Getting Service.

Table 27 Replacement Part Numbers

Description	Part Number
12 Vdc Charger	Q-FCTCHG
12 Vdc Battery	Q155193A
FC+ Control Board	Q20000200

Getting Service

If you are experiencing any difficulties, contact Federal Signal Customer Support at 800-548-7229 or 708-534-3400 extension 7511 or Technical Support at 800-524-3021 or 708-534-3400 extension 7329 or e-mail at techsupport@fedsig.com. For instruction manuals and information on related products, visit <http://www.fedsig.com>.

Appendix A Wiring Diagrams

Figure 8 Single Motor Wiring

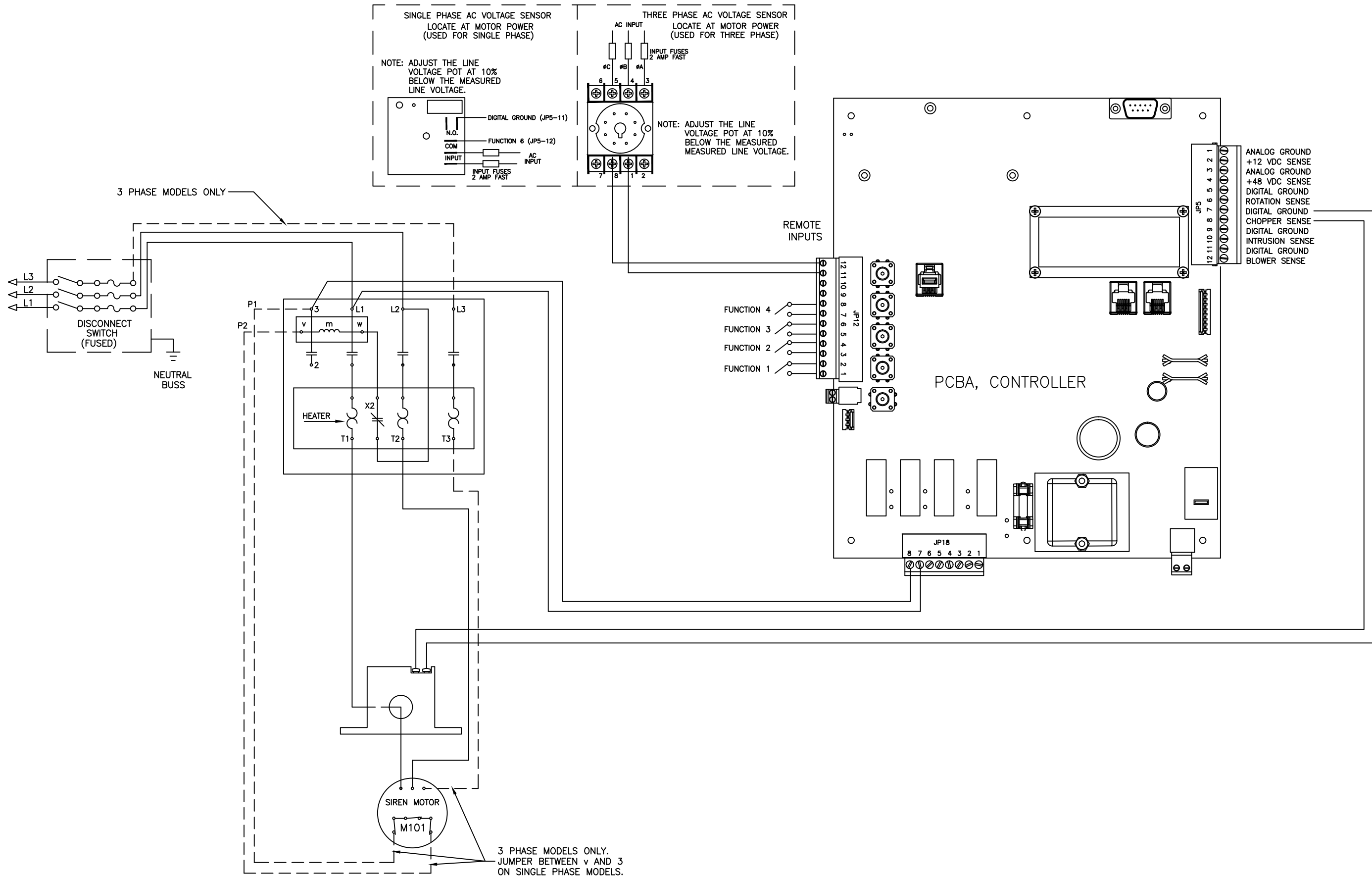

Figure 9 T-Bolt Wiring

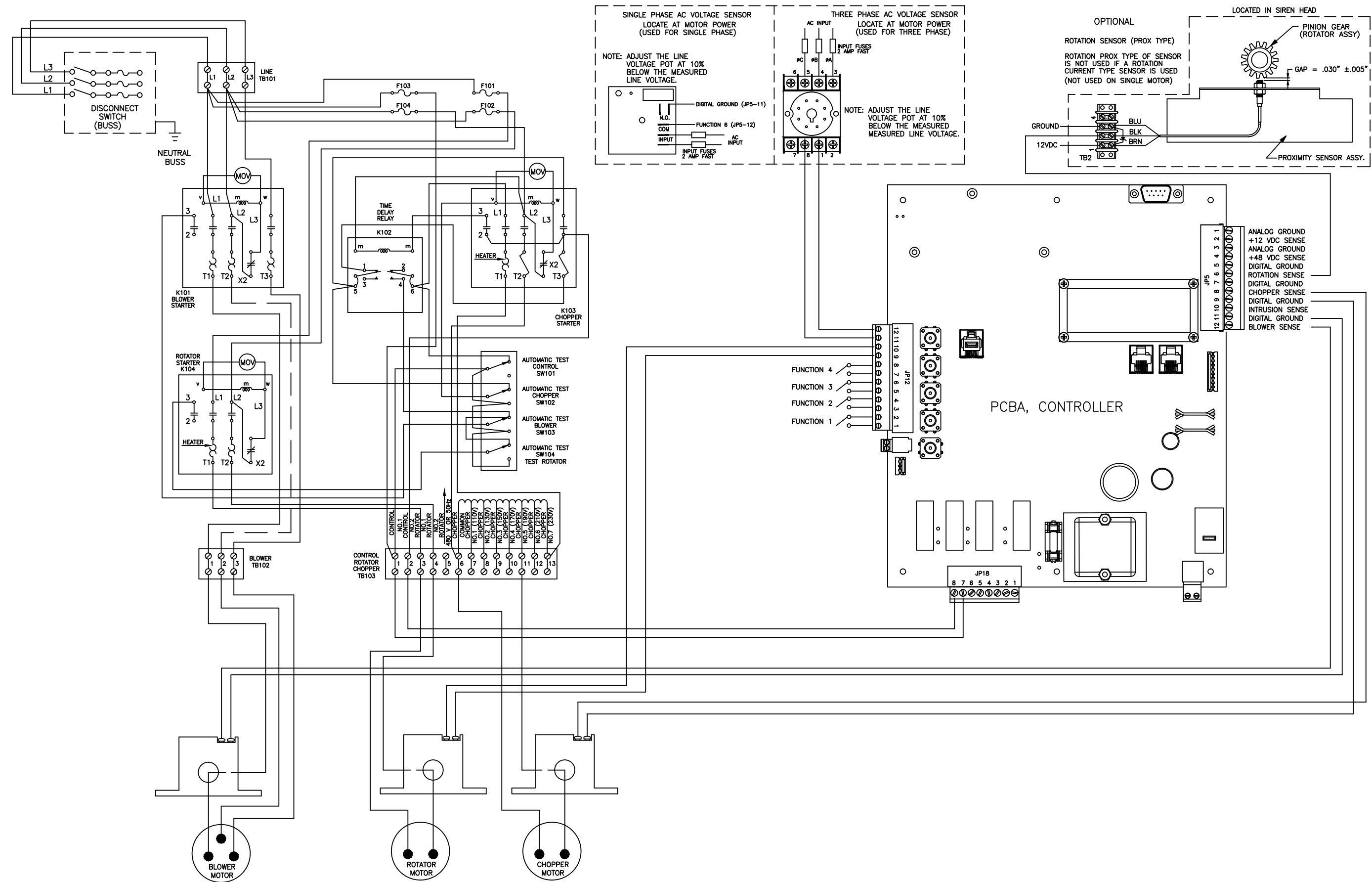
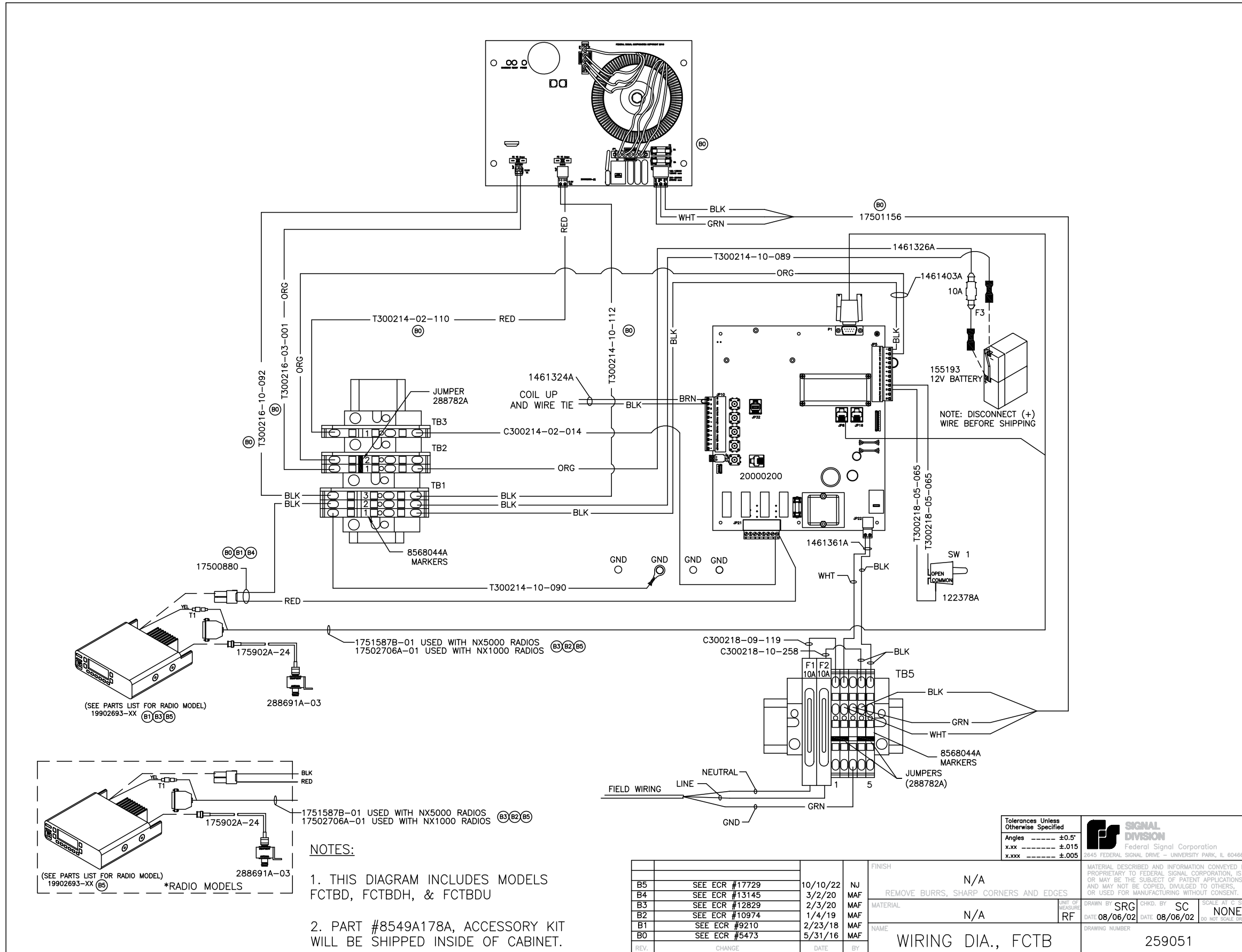

Figure 10 FCTB Wiring Diagram



NOTES:
 1. THIS DIAGRAM INCLUDES MODELS FCTBD, FCTBDH, & FCTBDU
 2. PART #8549A178A, ACCESSORY KIT WILL BE SHIPPED INSIDE OF CABINET.

Tolerances Unless Otherwise Specified
 Angles ----- ±0.5°
 x.xx ----- ±.015
 x.xxx ----- ±.005

SIGNAL DIVISION
 Federal Signal Corporation
 2645 FEDERAL SIGNAL DRIVE - UNIVERSITY PARK, IL 60466

MATERIAL DESCRIBED AND INFORMATION CONVEYED IS PROPRIETARY TO FEDERAL SIGNAL CORPORATION, IS OR MAY BE THE SUBJECT OF PATENT APPLICATIONS, AND MAY NOT BE COPIED, DIVULGED TO OTHERS, OR USED FOR MANUFACTURING WITHOUT CONSENT.

REV.	CHANGE	DATE	BY	NAME	FINISH	SCALE AT C SIZE
B5	SEE ECR #17729	10/10/22	NJ	N/A	N/A	NONE
B4	SEE ECR #13145	3/2/20	MAF	REMOVE BURRS, SHARP CORNERS AND EDGES		
B3	SEE ECR #12829	2/3/20	MAF			
B2	SEE ECR #10974	1/4/19	MAF			
B1	SEE ECR #9210	2/23/18	MAF			
B0	SEE ECR #5473	5/31/16	MAF			
WIRING DIA., FCTB						

DRAWN BY: SRG
 DATE: 08/06/02
 CHKD. BY: SC
 DATE: 08/06/02
 SCALE: NONE
 DRAWING NUMBER: 259051

Figure 11 FCTBD-IP Wiring Diagram

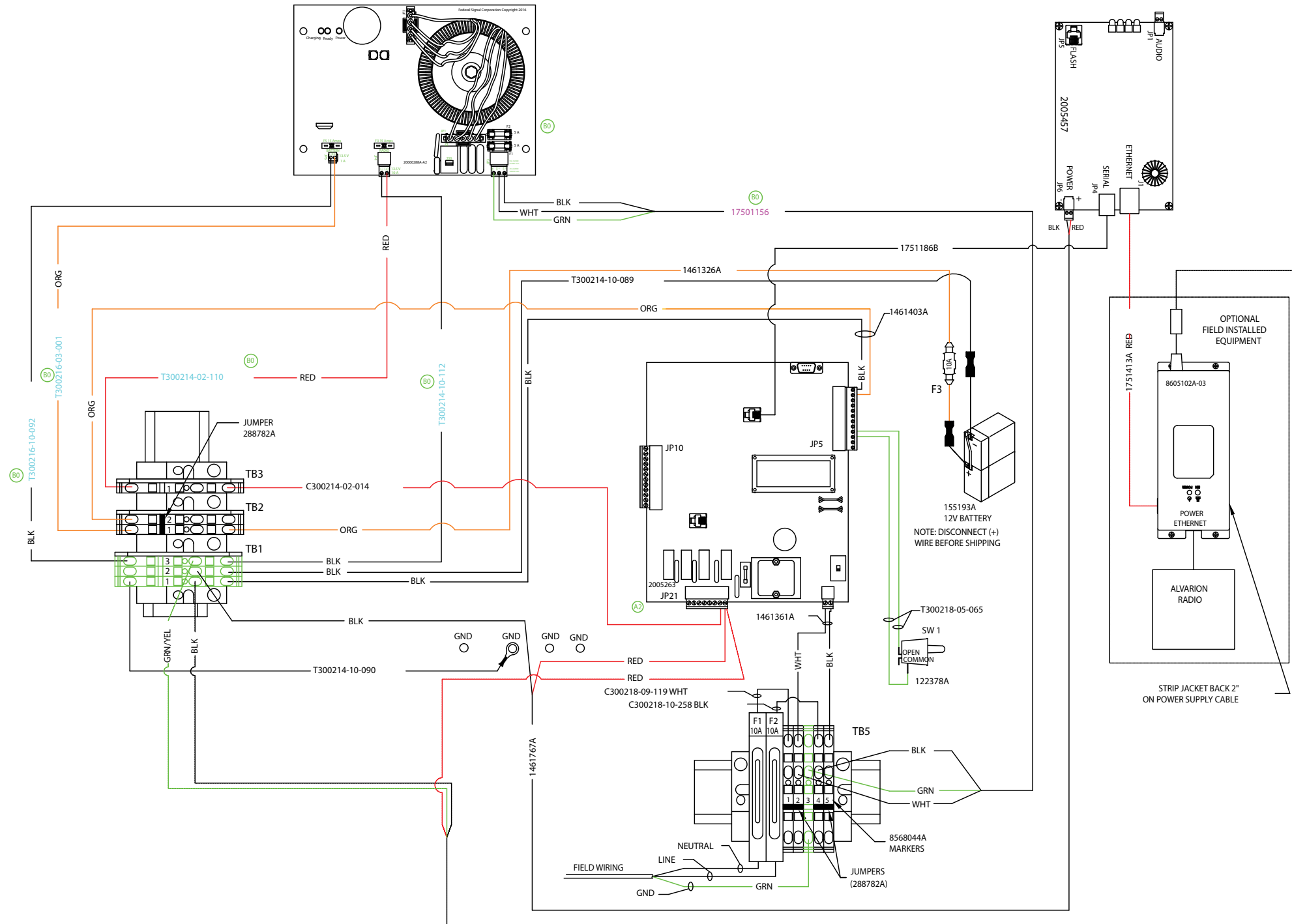

Tolerances Unless Otherwise Specified	
Angles	±0.5°
xxx	±0.15
xxxx	±0.05

B0 SEE ECR #5473 5/31/16 MAF
 A2 SEE ECR #10-6419 5/5/10 VT
 A1 SEE ECR #09-4970 7/2/09 MAF
 A REL TO PROD. ECO 07-4160 10/29/07 MAF

N/A
 N/A RF MAF RC NONE
 8/16/07 10/25/07
 WIRING DIA, BROADBAND, FCTBD-IP 259264