

25500811 Rev A1 1022

Safety Message to Installers of Siren Speakers

⚠ WARNING

People's lives depend on your proper installation and servicing of Federal Signal products. It is important to read and follow all instructions shipped with this product and the original product. Listed below are some other important safety instructions and precautions you should follow:

Before Installation

Qualifications

- To properly install an electronic siren, you must have a good understanding of automotive electrical procedures and systems, along with proficiency in the installation and service of safety warning equipment. Always refer to the vehicle's service manuals when installing equipment on a vehicle.

Sound Hazards

- Your hearing and the hearing of others in or near your emergency vehicle could be damaged by loud sounds. This can occur from short exposures to very loud sounds, or from longer exposures to moderately loud sounds. For hearing conservation guidance, refer to federal, state, or local recommendations. OSHA Standard 1910.95 offers guidance on "Permissible Noise Exposure."
- All effective sirens and horns produce loud sounds (120 dB) that may cause permanent hearing loss. Always minimize your exposure to the sound of the siren or horn and wear hearing protection. Do not sound the siren or horn indoors or in enclosed areas where you and others will be exposed to the sound.
- Federal Signal siren amplifiers and speakers are designed to work together as a system. Combining a siren and speaker from different manufacturers may reduce the warning effectiveness of the siren system and may damage the components. Verify or test your combination to make sure the system works together properly and meets federal, state, and local standards or guidelines.

During Installation

- DO NOT get metal shavings inside the product. Metal shavings can cause the system to fail. If drilling must be done near the unit, place an ESD-approved cover over the unit to prevent metal shavings from entering the unit. Inspect the unit after mounting to be sure there are no shavings present in or near the unit.
- To avoid a battery explosion, always disconnect the negative battery cable first and reconnect it last. Avoid causing a spark when connecting near or to the battery. The gases produced by a battery can cause a battery explosion that could result in vehicle damage and serious injury.
- DO NOT connect this system to the vehicle battery until ALL other electrical connections are made, mounting of all components is complete, and you have verified that no shorts exist. If wiring is shorted to the vehicle frame, high current conductors can cause hazardous sparks, resulting in electrical fires or flying molten metal.
- Ensure that the siren amplifier and speaker(s) in your installation have compatible wattage ratings
- In order for the electronic siren to function properly, the ground connection must be made to the NEGATIVE battery terminal.

Mounting the DFC-SB-750501 on the DFC-PB-xxxx Push Bumper

- Sound output will be severely reduced if any objects are in front of the speaker. If maximum sound output is required for your application, ensure that the front of the speaker is clear of any obstructions.
- Install the speaker(s) as far forward on the vehicle as possible in a location that provides maximum signaling effectiveness while minimizing the sound reaching the vehicle's occupants. Refer to the National Institute of Justice guide 500-00 for further information.
- Sound propagation and warning effectiveness will be severely reduced if the speaker is not facing forward. Carefully follow the installation instructions and always install the speaker with the projector facing forward.
- DO NOT install the speaker(s) or route the speaker wires where they may interfere with the operation of airbag sensors.
- If a vehicle seat is temporarily removed, verify with the vehicle manufacturer if the seat needs to be recalibrated for proper airbag deployment.
- Installation of two speakers requires that you wire the speakers in phase.
- Never attempt to install aftermarket equipment that connects to the vehicle wiring without reviewing a vehicle wiring diagram, which is available from the vehicle manufacturer. Ensure that your installation will not affect vehicle operation and safety functions or circuits. Always check vehicle for proper operation after installation.
- DO NOT install equipment or route wiring or cord in the deployment path of an airbag.
- Locate the control head so the vehicle, controls, and microphone can be operated safely.
- When drilling into a vehicle structure, ensure that both sides of the surface are clear of anything that could be damaged.

After Installation

- After installation, test the siren system and light system to ensure that it is operating properly.
- Test all vehicle functions, including horn operation, vehicle safety functions, and vehicle light systems, to ensure proper operation. Ensure that installation has not affected vehicle operation or changed any vehicle safety function or circuit.
- After testing is complete, provide a copy of these instructions to the instructional staff and all operating personnel.
- File these instructions in a safe place and refer to them when maintaining or reinstalling the product.

Failure to follow all safety precautions and instructions may result in property damage, serious injury, or death.

Unpacking the Product

After unpacking the product, inspect it for damage that may have occurred in transit. If it has been damaged, do not attempt to install or operate it. File a claim immediately with the carrier stating the extent of damage. Carefully check all envelopes, shipping labels, and tags before removing or destroying them. Ensure that the parts listed in Table 1 are included in the package. If you are missing any parts, contact Customer Support at 1-800-264-3578, 7 a.m. to 5 p.m., Monday through Friday (CT).

Model DFC-SB-750501 Mounting Bracket Kit for AS124

This publication has instructions for using the Model DFC-SB-750501 mounting bracket kit to mount the AS124 on the DFC-PB-xxxx push bumper.

NOTE: For electrical installation instructions, refer to the installation and maintenance Instructions packaged with the speaker.

Unpacking the Kit

After unpacking the kit, inspect it for damage that may have occurred in transit. If it has been damaged, do not attempt to install or operate it. File a claim immediately with the carrier, stating the extent of damage. Carefully check all envelopes, shipping labels, and tags before removing or destroying them. Ensure that the parts in the Kit Contents List are included in the package. If you are missing any parts, contact Customer Support at 1-800-264-3578, 7 a.m. to 5 p.m., Monday through Friday (CT).

Table 1 Kit contents

Item	Description	Part Number	Qty.
1	AS124 Push Bumper Bracket	806203646A	1
2	3/8-16 Button Head Bolt	70001468A-16	2
3	3/8-inch Lock Washer	70701469A	2

Installing the Brackets

⚠ WARNING

AIRBAG DEPLOYMENT: Do not install equipment or route wiring in the deployment path of an airbag. Failure to observe this warning will reduce the effectiveness of the airbag or potentially dislodge the equipment, causing serious injury or death.

Mounting the Speaker to the Bracket

⚠ WARNING

MOUNTING PRECAUTIONS: To avoid reducing the sound output and/or damaging the speaker, ensure that the speaker is mounted with the wires protruding from the bottom of the speaker. Failure to follow this warning may cause serious injury or death.

To mount the speaker:

1. Install the AS124 speaker (not included) to the bracket (Item 1) using the hardware that is included with the speaker. See Figure 1.

Figure 1 Attach speaker to bracket

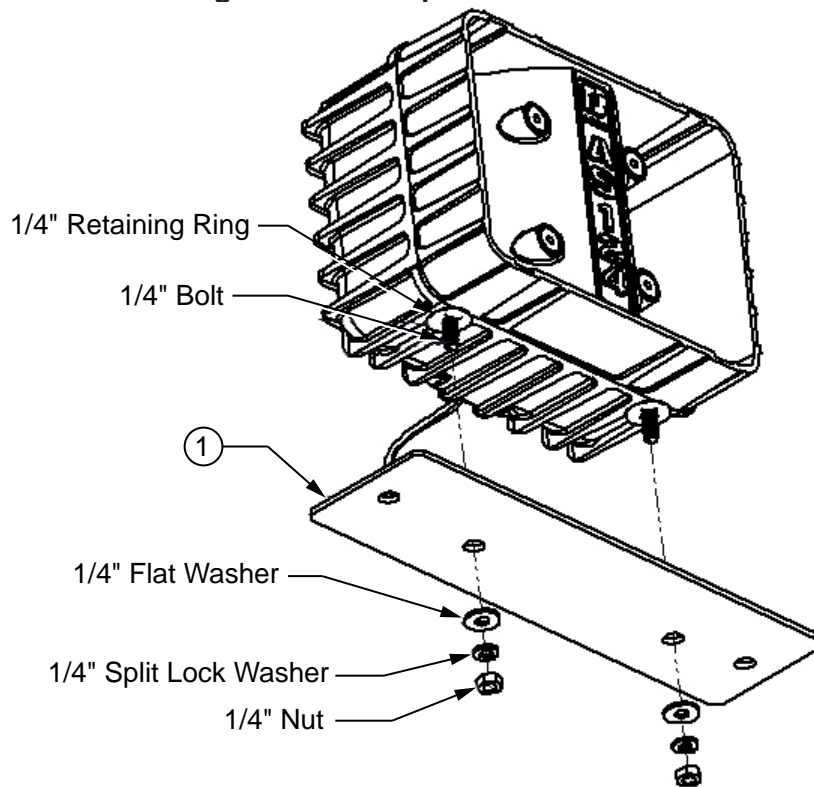

NOTE: The speaker can be installed on either the driver or the passenger side, but the orientation of the bracket will matter. See Figures 2 and 3.

Figure 2 Driver side mounting orientation

Front Side of Speaker

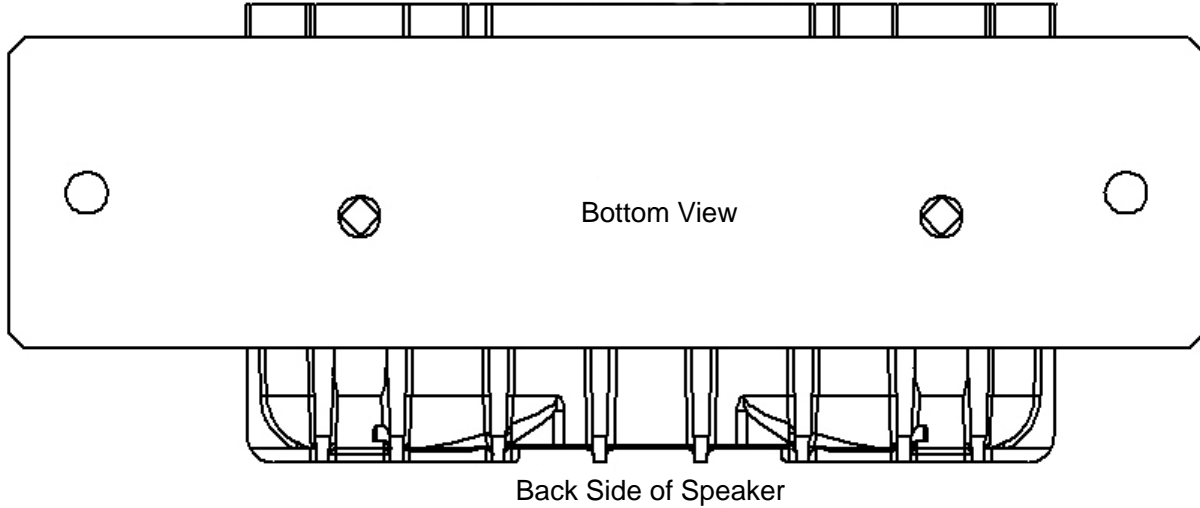
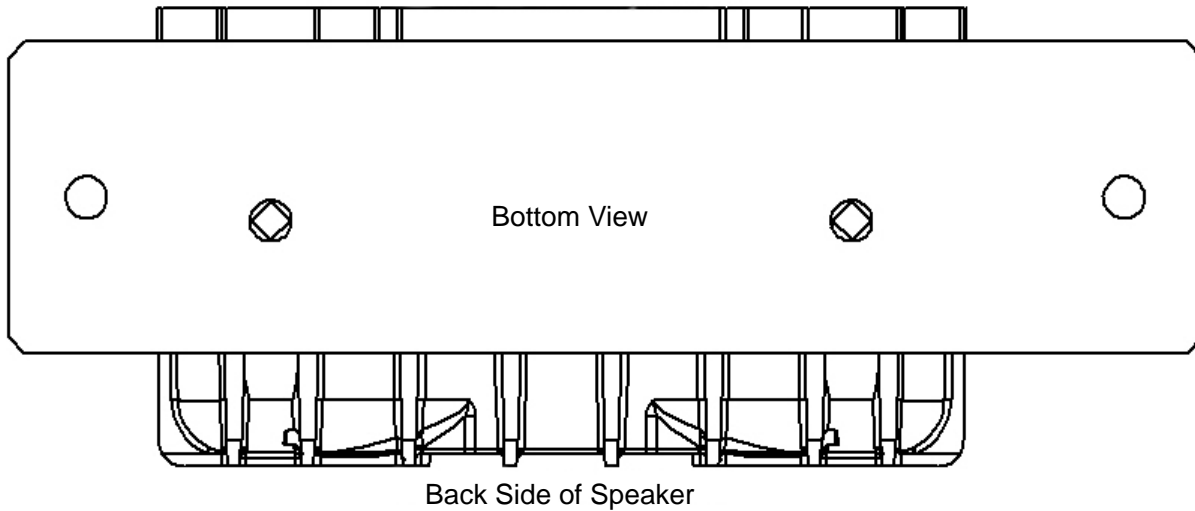

Figure 3 Passenger side mounting orientation

Front Side of Speaker



2. Using the supplied hardware (Items 2 and 3), install the bracket to the middle channel of the push bumper. See Figure 4.

Figure 4 Speaker installed

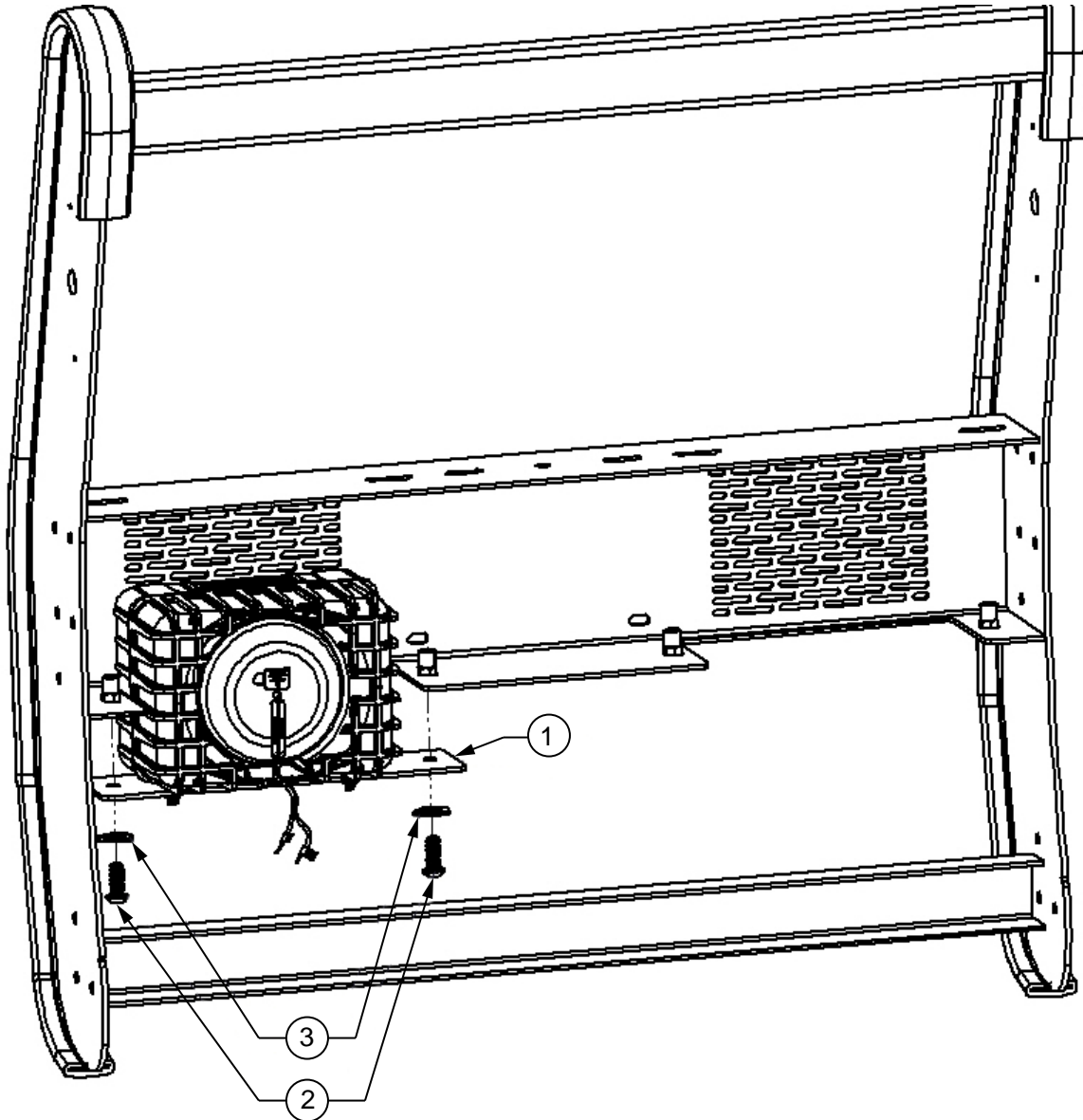

3. Wire the speaker according to the instructions packed with the speaker.

Maintaining the Brackets

Regularly clean the textured powder coat finishes with either a soft cloth or a brush with a mild soap and warm water. Avoid using any harsh chemicals, as this will damage the product's finish. Pressure washing this product is the most efficient way to remove heavy dirt and grime. The pressure washer should be used on a low pressure setting with filtered water for best results. Using high pressure can damage the product's finish.

Getting Technical Support

For technical support, please contact:

Federal Signal Corporation
Service Department
Phone: 1-800-433-9132
Email: empSERVICEinfo@fedSIG.com

Getting Repair Service

The Federal Signal factory provides technical assistance with any problems that cannot be handled locally. Any units returned to Federal Signal for service, inspection, or repair must be accompanied by a Return Material Authorization (RMA). Obtain an RMA from a local Distributor or Manufacturer's Representative. Provide a brief explanation of the service requested or the nature of the malfunction.

Address all communications and shipments to the following:

Federal Signal Corporation
Service Department
2645 Federal Signal Dr.
University Park, IL 60484-3167

Ordering Replacement Parts

To order replacement parts, call Customer Support at 1-800-264-3578, 7 a.m. to 5 p.m., Monday through Friday (CT) or contact your nearest distributor.

Limited Warranty

This product is subject to and covered by a limited warranty, a copy of which can be found at www.fedSIG.com/SSG-Warranty. A copy of this limited warranty can also be obtained by written request to Federal Signal Corporation, 2645 Federal Signal Drive, University Park, IL 60484, email to info@fedSIG.com or call +1 708-534-3400.

This limited warranty is in lieu of all other warranties, express or implied, contractual or statutory, including, but not limited to the warranty of merchantability, warranty of fitness for a particular purpose and any warranty against failure of its essential purpose.



FEDERAL SIGNAL
Safety and Security Systems

2645 Federal Signal Drive
University Park, Illinois 60484-3167

www.fedsig.com

Customer Support

Police/Fire-EMS: 800-264-3578 • +1 708 534-3400

Work Truck: 800-824-0254 • +1 708 534-3400

Technical Support: 800-433-9132 • +1 708 534-3400

© Copyright 2022 Federal Signal Corporation

All product names or trademarks are properties of their respective owners.