

**INSTRUCTION SHEET  
FOR  
SYNCHRONIZED SIMULTANEOUS FLASH LED WARNING LIGHT MODULES**

**SAFETY MESSAGE TO INSTALLERS**



People's lives depend on your safe installation of our products. It is important to read, understand and follow all instructions shipped with the products. In addition, listed below are some other important safety instructions and precautions you should follow:

- **To properly install this warning light: you must have a good understanding of automotive electrical procedures and systems, along with proficiency in the installation and use of safety warning equipment.**
- **When drilling into a vehicle structure, be sure that both sides of the surface are clear of anything that could be damaged.**
- **DO NOT install equipment or route wiring or cord in the deployment path of an air bag.**
- **You should frequently inspect the light to ensure that it is operating properly and securely attached.**
- **This product contains high intensity LED devices. To prevent eye damage, DO NOT stare into the light beam at close range.**
- **Locate light control so the vehicle and light can be safely operated in all driving conditions.**
- **Do not attempt to activate the light while driving in a hazardous situation.**
- **Place all warning labels provided, in a visible location on the equipment.**
- **File this instruction sheet in a safe place and refer to it when maintaining and/or reinstalling the product.**

**Failure to follow all safety precautions and instructions may result in property damage, serious injury or death to you or others.**

**I. GENERAL.**

The Federal Signal 4" round, 5" round, and 6-1/2" oval LED modules are sealed, low current devices designed for warning purposes. These models are self-flashing units for auxiliary emergency warning. These warning lights can be used either with their own internal flasher, or synchronized with several other lights. They can be powered by 12-24 VDC.

**II. UNPACKING.**

After unpacking the part, inspect it for damage that may have occurred in transit. If it has been damaged, file a claim immedi-

ately with the carrier, stating the extent of damage. Carefully check all envelopes, shipping labels, and tags before removing or destroying them.

**III. KIT CONTENTS LIST.**

Qty	Description
1	Warning light
1	Mounting grommet
1	Wire harness

**IV. INSTALLATION.**

**NOTE**

Read all instructions and plan all wiring and cable routing before performing any installation. Use grommets, wire ties, looms, and cable mounts (installer supplied) as needed to secure the wiring and to prevent chafing of the wiring.

The red, black and white wires on the harness supplied with this unit are not compatible with strobe power supplies.

- A. Determine the mounting location for the light and user-supplied control switch.
- B. Route an 18 GA wire from the power source to the switch location. Install an user-supplied fuse and fuseholder as close to the power source as possible. Each pair of lights should have a 2-ampere fuse. Two pairs should have a 4-ampere fuse.
- C. Route an 18 GA wire from the switch to the desired location of the light.
- D. Route an 18 GA wire from light installation area to the nearest convenient chassis ground. The battery is recommended.
- E. Note that the back of the light has the function of each pin marked.
- F. The warning light's pins are labeled as shown in table 1.
- G. Wire the warning lights using one of the two methods as follows:

1. Internal Flasher.

Using installer-supplied weather resistant terminals, connect the black wire to ground. The red wire is connected to positive (+) 12-24 VDC via an installer-supplied switch rated for 1-ampere for each light on that circuit. The green wire is left disconnected.

2. Synchronized Flash.

Up to four LED modules can be attached to synchronize the flash pattern. When connected in this way, all light modules will flash simultaneously.

Using figure 1 as a guide, connect the black (-) wires from all LED modules to common ground. The red wire from head 1 and the red wire from head 2 are connected together, and then

Table 1.

Par 36/Oval	Par 46	Function
"GND", black	"GND", black	Ground (-)
"TAIL", yellow	"AUX", yellow	Simultaneous flash override
"STOP", red	"PWR", red	Power for internal flasher (+)

connected to a common power source (+12-24VDC). The green wire from head 1 and the yellow wire from head 2 are also connected together. Any additional heads are connected in the same manner.

**CAUTION**

Before drilling or cutting holes in ANY part of a vehicle, be sure that both sides of the mounting surface are clear of parts that could be damaged; such as brake lines, electrical wiring or other vital parts.

H. Cut a 4-1/2" round, a 6" round, or 6-5/8" x 2-1/2 oval opening for the light at the desired location, or install the Federal

Signal Corporation Model 601320 (round) or 610310 (oval) bracket kit. Orient the grommet with the lettering upright and insert it into the opening for the light.

I. Pass the connector end of the wire harness through the opening. Allow enough excess wire to permit servicing of the light after installation

J. Connect the LED module to the plug. Use silicone dielectric grease to lubricate the connector gasket if the grease in the socket has been depleted.

K. See figure 2. Orient the LED Module with the lettering upright and push it into the gasket until seated. Apply pressure to the top and bottom alternately. A firm, steady pressure is needed.

L. Check the wiring and test for proper operation.

Copyright 2005 Federal Signal Corporation

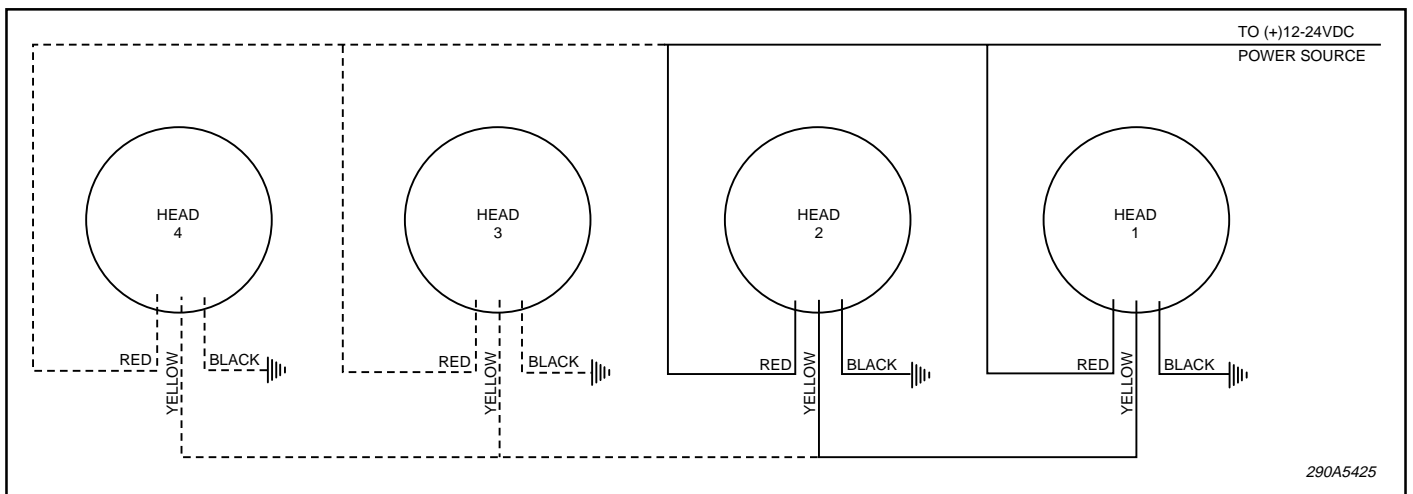

Figure 1.

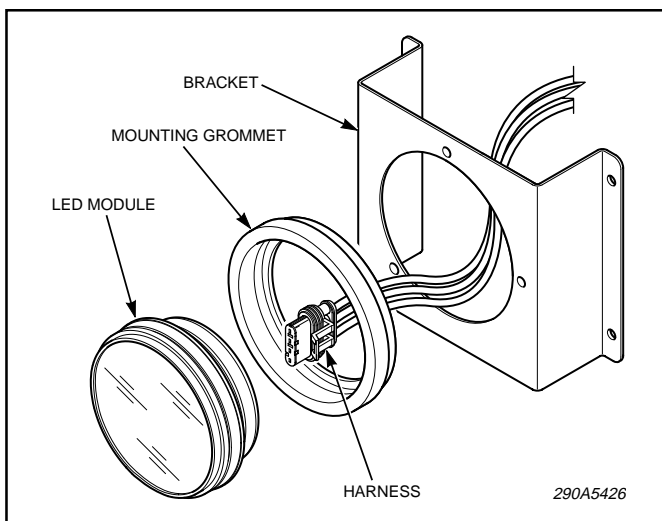

Figure 2.