

Safety Message to Installers of Siren Speakers

⚠ WARNING

People's lives depend on your proper installation and servicing of Federal Signal products. It is important to read and follow all instructions shipped with this product and the original product. Listed below are some other important safety instructions and precautions you should follow.

Before Installation

Qualifications

- To properly install an electronic siren, you must have a good understanding of automotive electrical procedures and systems, along with proficiency in the installation and service of safety warning equipment. Always refer to the vehicle's service manuals when installing equipment on a vehicle.

Sound Hazards

- Your hearing and the hearing of others, in or near your emergency vehicle, could be damaged by loud sounds. This can occur from short exposures to very loud sounds, or from longer exposures to moderately loud sounds. For hearing conservation guidance, refer to federal, state, or local recommendations. OSHA Standard 1910.95 offers guidance on "Permissible Noise Exposure."
- All effective sirens and horns produce loud sounds (120 dB) that may cause permanent hearing loss. Always minimize your exposure to the sound of the siren or horn and wear hearing protection. Do not sound the siren or horn indoors or in enclosed areas where you and others will be exposed to the sound.
- Federal Signal siren amplifiers and speakers are designed to work together as a system. Combining a siren and speaker from different manufacturers may reduce the warning effectiveness of the siren system and may damage the components. You should verify or test your combination to make sure the system works together properly and meets federal, state, and local standards or guidelines.

During Installation

- DO NOT get metal shavings inside the product. Metal shavings can cause the system to fail. If drilling must be done near the unit, place an ESD-approved cover over the unit to prevent metal shavings from entering the unit. Inspect the unit after mounting to be sure there are no shavings present in or near the unit.
- To avoid a battery explosion, always disconnect the negative battery cable first and reconnect it last. Avoid causing a spark when connecting near or to the battery. The gases produced by a battery can cause a battery explosion that could result in vehicle damage and serious injury.
- DO NOT connect this system to the vehicle battery until ALL other electrical connections are made, mounting of all components is complete, and you have verified that no shorts exist. If wiring is shorted to the vehicle frame, high current conductors can cause hazardous sparks, resulting in electrical fires or flying molten metal.
- Make sure the siren amplifier and speaker(s) in your installation have compatible wattage ratings.
- In order for the electronic siren to function properly, the ground connection must be made to the NEGATIVE battery terminal.

- Sound output will be severely reduced if any objects are in front of the speaker. If maximum sound output is required for your application, ensure that the front of the speaker is clear of any obstructions.
- Install the speaker(s) as far forward on the vehicle as possible in a location that provides maximum signaling effectiveness while minimizing the sound reaching the vehicle's occupants. Refer to the National Institute of Justice guide 500-00 for further information.
- Sound propagation and warning effectiveness will be severely reduced if the speaker is not facing forward. Carefully follow the installation instructions, and always install the speaker with the projector facing forward.
- DO NOT install the speaker(s) or route the speaker wires where they may interfere with the operation of airbag sensors.
- If a vehicle seat is temporarily removed, verify with the vehicle manufacturer if the seat needs to be recalibrated for proper airbag deployment.
- The installation of two speakers requires that you wire the speakers in phase.
- Never attempt to install aftermarket equipment that connects to the vehicle wiring without reviewing a vehicle wiring diagram, which is available from the vehicle's manufacturer. Ensure that your installation will not affect vehicle operation and safety functions or circuits. Always check the vehicle for proper operation after installation.
- DO NOT install equipment or route wiring or cord in the deployment path of an airbag.
- Locate the control head so the vehicle, controls, and microphone can be operated safely.
- When drilling into a vehicle structure, ensure that both sides of the surface are clear of anything that could be damaged.
- If a vehicle seat is temporarily removed, verify with the vehicle manufacturer if the seat needs to be recalibrated for proper airbag deployment.

After Installation

- After installation, test the siren system and light system to ensure that it is operating properly.
- Test all vehicle functions, including horn operation, vehicle safety functions, and vehicle light systems, to ensure proper operation. Ensure that installation has not affected vehicle operation or changed any vehicle safety function or circuit.
- After testing is complete, provide a copy of these instructions to the instructional staff and all operating personnel.
- File these instructions in a safe place and refer to them when maintaining or reinstalling the product.

Failure to follow all safety precautions and instructions may result in property damage, serious injury, or death.

Introduction

RBC2PB-FPIU20 and RBC1PB-FPIU20 are the mounting kits for the Federal Signal Compact Rumbler speaker. These kits mount the speaker to the front bumper of the 2020 Police Ford Intercept Utility Vehicle with Pit bars.

Unpacking the Kit

After unpacking the kit, inspect it for damage that may have occurred in transit. If it has been damaged, do not attempt to install or operate it. File a claim immediately with the carrier, stating the extent of damage. Carefully check all envelopes, shipping labels, and tags before removing or destroying them. Ensure that the parts in the appropriate Kit Contents List are included in the package. If you are missing any parts, contact Customer Support at 1-800-264-3578, 7 a.m. to 5 p.m., Monday through Friday (CT).

Table 1 RBC2PB-FPIU20 Kit Contents

Qty.	Description	Part Number
1	2020 FPIU with Pit Bar Rumbler Driver Side Bracket Assembly	828304480A-DS
1	2020 FPIU with Pit Bar Rumbler Passenger Side Bracket Assembly	828304480A-PS
4	1.50" OD Flat Washer	7072255A

Table 2 RBC1PB-FPIU20 Kit Contents

Qty.	Description	Part Number
1	2020 FPIU with Pit Bar Rumbler Driver Side Bracket Assembly	828304480A-DS
2	1.50" OD Flat Washer	7072255A

Installing the Bracket

⚠ WARNING

FIRE HAZARD: Do not install the speaker near the fuel tank or fuel lines. Installing the speaker too close to fuel line/tank areas may cause fuel leakage or a fire during a vehicle collision, causing personal injury or death.

NOTICE

MOUNTING PRECAUTIONS: To avoid reducing the sound output and damaging the speaker, ensure that the speaker is mounted with the wires protruding from the bottom of the speaker and the slots facing the ground.

NOTICE

DRILLING PRECAUTIONS: Before drilling holes, check the area you are drilling into to be sure you do not damage vehicle components while drilling. All drilled holes should be de-burred, and all sharp edges should be smoothed. All wire routings going through drilled holes should be protected by a grommet or convolute/split loom tubing.

Installing the Speaker

The steps for mounting a speaker on the driver side and the passenger side are the same. To mount a speaker bracket:

1. To access the area behind the bumper located in front of the front wheel on the driver side, remove the fascia according to the manufacturer's service manual.
2. With the pit bar mounted, remove the bolts on the driver side of the vehicle frame where the bracket will be mounted. See Figure 1.

Figure 1 Bolts (Passenger side shown)

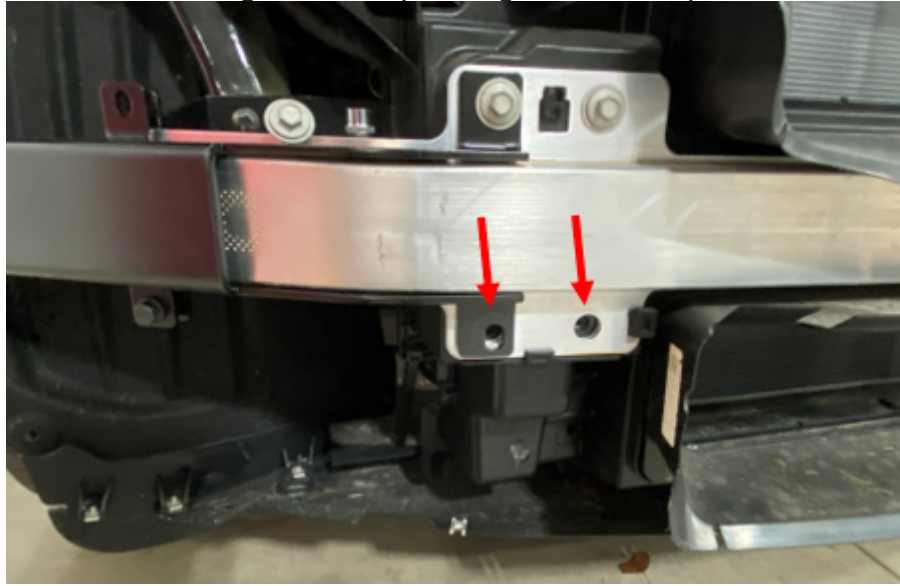

NOTE: Some additional modifications to the mounting area may be required.

3. Mount the Compact Rumbler Speaker using the four Plastite® screws that were included with the speaker. Torque the screws to 75 in-lb. See Figure 2.

Figure 2 Mount the Speaker

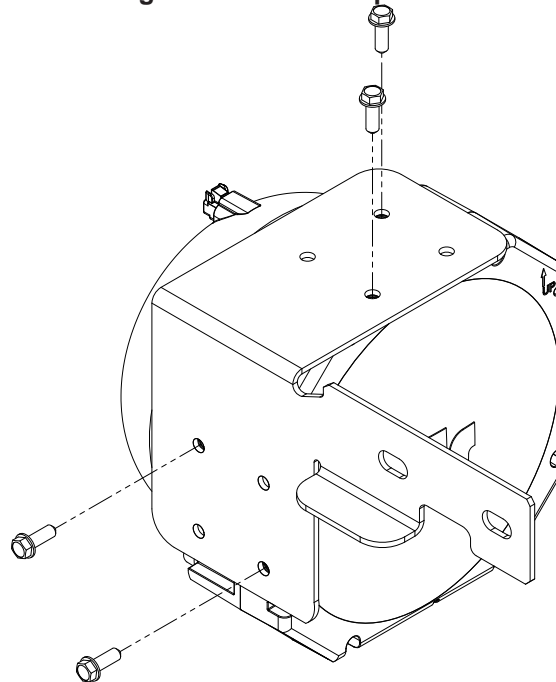

NOTICE

DRILLING PRECAUTIONS: When drilling holes, check the area you are drilling into to ensure that you do not damage vehicle components while drilling. All drilled holes should be de-burred, and all sharp edges should be smoothed. All wire routings going through drilled holes should be protected by a grommet or convolute/split loom tubing.

4. With the speaker mounted to the bracket, place the bracket on the bumper, positioning the mounting holes over the bumper bolts that were removed in step 2. With the bracket and speaker positioned, place two spacer washers between the bumper bar and the bracket on the hole mount that does not mount the pit bar bracket.
5. Tighten the bolts by hand, centering the bolts in the slot holes of the bracket.
6. If you are installing the RBC2PB-FPIU20 kit, secure the frame bolts and repeat steps 2 through 6 for the driver side.

Figure 3 Bracket (Passenger side shown)



NOTE: When mounting the driver side bracket, relocate the rubber harness mount found behind the driver side bumper.

7. Complete the speaker installation according to the speaker's instructions.

⚠ WARNING

SOUND HAZARD: All effective sirens and horns produce loud sounds (120 dB) that may cause permanent hearing loss. Always minimize your exposure to siren sound and wear hearing protection. Do not sound siren indoors or in enclosed areas where you and others will be exposed to the sound.

8. Test the siren for proper operation.
9. Reassemble the vehicle according to the manufacturer's service manual.

Getting Technical Support and Service

For technical support and service, contact:

Service Department
Federal Signal Corporation
Phone: 1-800-433-9132
Email: empsserviceinfo@fedsig.com

Getting Repair Service

The Federal Signal factory provides technical assistance with any problems that cannot be handled locally.

Any units returned to Federal Signal for service, inspection, or repair must be accompanied by a Return Material Authorization (RMA). Obtain an RMA from a local Distributor or Manufacturer's Representative.

Provide a brief explanation of the service requested or the nature of the malfunction.

Address all communications and shipments to the following:

Federal Signal Corporation
Service Department
2645 Federal Signal Drive
University Park, IL 60484-3167

Ordering Replacement Parts

To order replacement parts, call Customer Support at 1-800-264-3578, 7 a.m. to 5 p.m., Monday through Friday (CT), or contact your nearest distributor.

Limited Warranty

This product is subject to and covered by a limited warranty, a copy of which can be found at www.fedsig.com/SSG-Warranty. A copy of this limited warranty can also be obtained by written request to Federal Signal Corporation, 2645 Federal Signal Drive, University Park, IL 60484, email to info@fedsig.com or call to +1 708-534-3400.

This limited warranty is in lieu of all other warranties, express or implied, contractual or statutory, including, but not limited to the warranty of merchantability, warranty of fitness for a particular purpose and any warranty against failure of its essential purpose.



FEDERAL SIGNAL
Safety and Security Systems

2645 Federal Signal Drive
University Park, Illinois 60484-3167

www.fedsig.com

Customer Support

Police/Fire-EMS: 800-264-3578 • +1 708 534-3400

Work Truck: 800-824-0254 • +1 708 534-3400

Technical Support: 800-433-9132 • +1 708 534-3400

© 2023 Federal Signal Corporation

All trademarks are property of their respective owners.