

25500482 REV. A1 0620

Safety Message to Installers of Sound and Light Systems

⚠ WARNING

People's lives depend on your proper installation and servicing of Federal Signal products. It is important to read and follow all instructions shipped with this product and the original product. Listed below are some other important safety instructions and precautions you should follow.

Before Installation

Qualifications

- To properly install an electronic siren, you must have a good understanding of automotive electrical procedures and systems, along with proficiency in the installation and service of safety warning equipment. Always refer to the vehicle's service manuals when installing equipment on a vehicle.

Sound Hazards

- Your hearing and the hearing of others, in or near your emergency vehicle, could be damaged by loud sounds. This can occur from short exposures to very loud sounds, or from longer exposures to moderately loud sounds. For hearing conservation guidance, refer to federal, state, or local recommendations. OSHA Standard 1910.95 offers guidance on "Permissible Noise Exposure."
- All effective sirens and horns produce loud sounds (120 dB) that may cause permanent hearing loss. Always minimize your exposure to siren sound and wear hearing protection. Do not sound the siren indoors or in enclosed areas where you and others will be exposed to the sound.
- Federal Signal siren amplifiers/relay modules and speakers are designed to work together as a system. Combining a siren and speaker from different manufacturers may reduce the warning effectiveness of the siren system and may damage the components. You should verify or test your combination to make sure the system works together properly and meets federal, state and local standards or guidelines.

During Installation

- DO NOT get metal shavings inside the product. Metal shavings can cause the system to fail. If drilling must be done near the unit, place an ESD-approved cover over the unit to prevent metal shavings from entering the unit. Inspect the unit after mounting to be sure there are no shavings present in or near the unit.
- DO NOT connect this system to the vehicle battery until ALL other electrical connections are made, mounting of all components is complete, and you have verified that no shorts exist. If wiring is shorted to vehicle frame, high current conductors can cause hazardous sparks resulting in electrical fires or flying molten metal.
- Ensure that the siren amplifier/relay modules and speaker(s) in your installation have compatible wattage ratings.
- In order for the electronic siren to function properly, the ground connection must be made to the NEGATIVE battery terminal.
- Sound output will be severely reduced if any objects are in front of the speaker. If maximum sound output is required for your application, you should ensure that the front of the speaker is clear of any obstructions.

Pathfinder Vehicle Interface Cable for Dodge Charger

- Install the speaker(s) as far forward on the vehicle as possible, in a location that provides maximum signaling effectiveness while minimizing the sound reaching the vehicle's occupants. Refer to the National Institute of Justice guide 500-00 for further information.
- Mounting the speakers behind the grille will reduce the sound output and warning effectiveness of the siren system. Before mounting speakers behind the grille, make sure the vehicle operators are trained and understand that this type of installation is less effective for warning others.
- Sound propagation and warning effectiveness will be severely reduced if the speaker is not facing forward. Carefully follow the installation instructions and always install the speaker with the projector facing forward.
- DO NOT install the speaker(s) or route the speaker wires where they may interfere with the operation of airbag sensors.
- Installation of two speakers requires that you wire the speakers in phase.
- Never attempt to install aftermarket equipment, which connects to the vehicle wiring, without reviewing a vehicle wiring diagram, which is available from the vehicle manufacturer. Ensure that your installation will not affect vehicle operation and safety functions or circuits. Always check vehicle for proper operation after installation.
- DO NOT install equipment or route wiring or cord in the deployment path of an airbag.
- If a vehicle seat is temporarily removed, verify with the vehicle manufacturer if the seat needs to be recalibrated for proper airbag deployment.
- Locate the control head so the vehicle, controls, and microphone can be operated safely.
- When drilling into a vehicle structure, ensure that both sides of the surface are clear of anything that could be damaged. All drilled holes should be deburred, and all sharp edges should be smoothed. All wires going through drilled holes should be protected by a grommet or convolute/split-loom tubing. All exterior drilled holes must be sealed with Motorcraft seam sealer T-A-2-B or equivalent to prevent the potential exposure to carbon monoxide or other potentially harmful fumes. Failure to observe this warning could cause serious injury or death.

After Installation

- After installation, test the siren system and light system to ensure that they are operating properly.
- Test all vehicle functions, including horn operation, vehicle safety functions, and vehicle light systems, to ensure proper operation. Ensure that installation has not affected vehicle operation or changed any vehicle safety function or circuit.
- After testing is complete, provide a copy of these instructions to the instructional staff and all operating personnel.
- File these instructions in a safe place and refer to them when maintaining and/or reinstalling the product.
- Failure to follow all safety precautions and instructions may result in property damage, serious injury, or death.

RETAIN AND REFER TO THESE MESSAGES.

Installing the Vehicle Interface Cable

This publication contains instructions for installing the Dodge Charger Vehicle Interface Cable.

To install the interface cable:

1. Locate the Pigtail harness that plugs into the VSIM 24-way C2 Connector. (See the Up-Fitters Guide for the vehicle for more information.) The VSIM connectors are located under the center console, near the bottom of the instrument panel.
2. Make the following solder or crimp connections between the 24-way C2 Pigtail harness and the Federal Signal 17501771 cable. Make connections using cavity numbers, since wire colors may vary.

Table 1 Connections

Dodge 24-way C2 Pigtail harness		Federal Signal 17501771		
Cavity	Color	Cavity	Color	Function
11	BR/DG	1	White	CAN bus (+)
12	BR/LG	3	Green	CAN bus (-)
16	BK	2	Brown	GND (Shield)

Figure 1 Cable 17501771 Pinouts

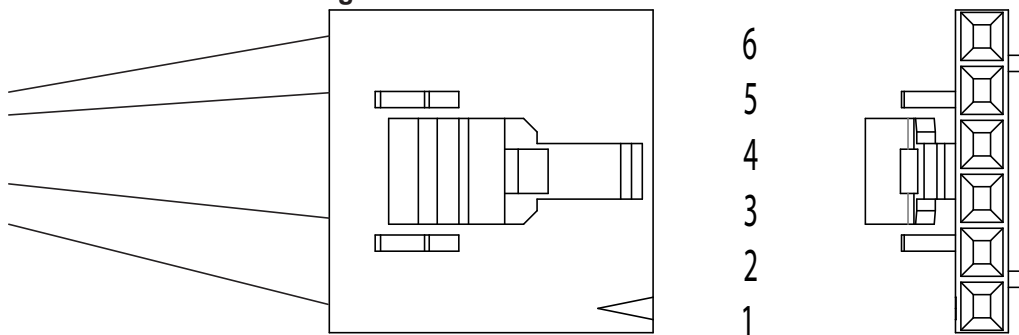

Connecting FS Vehicle Integration

To connect the Federal Signal vehicle integration:

1. Plug the VSIM 24-way C2 Connector harness into the vehicle.
2. Plug the 6-pin cable (17501771) into the Pathfinder Siren. Refer to the Pathfinder instructions 25500463.

Programming FS Vehicle Integration

All programming is done using the Convergence Configuration Software. You must know the vehicle's model year. Signals and vehicle events may vary by model year.

Getting Technical Support

For technical support, please contact:

Federal Signal Corporation
 Service Department
 Phone: 1-800-433-9132
 Email: emp-service-info@fedsig.com

Getting Repair Service

The Federal Signal factory provides technical assistance with any problems that cannot be handled locally. Any product returned to Federal Signal for service, inspection, or repair must be accompanied by a Return Material Authorization (RMA). Obtain a RMA from a local Distributor or Manufacturer's Representative. Provide a brief explanation of the service requested or the nature of the malfunction.

Address all communications and shipments to the following:

Federal Signal Corporation
Service Department
2645 Federal Signal Dr.
University Park, IL 60484-3167

Limited Warranty

This product is subject to and covered by a limited warranty, a copy of which can be found at www.fedsig.com/SSG-Warranty. A copy of this limited warranty can also be obtained by written request to Federal Signal Corporation, 2645 Federal Signal Drive, University Park, IL 60484, email to info@fedsig.com or call +1 708-534-3400.

This limited warranty is in lieu of all other warranties, express or implied, contractual or statutory, including, but not limited to the warranty of merchantability, warranty of fitness for a particular purpose and any warranty against failure of its essential purpose.



2645 Federal Signal Drive
University Park, Illinois 60484-3167

www.fedsig.com

Customer Support

Police/Fire-EMS: 800-264-3578 • +1 708 534-3400

Work Truck: 800-824-0254 • +1 708 534-3400

Technical Support: 800-433-9132 • +1 708 534-3400

© Copyright 2018-2020 Federal Signal Corporation
All trademarks are property of their respective owners.