

25500196 Rev. B0 0519

## Safety Message to Installers of Warning Light Equipment

### **⚠ WARNING**

People's lives depend on your proper installation and servicing of Federal Signal products. It is important to read and follow all instructions shipped with this product and the original product. In addition, listed below are some other important safety instructions and precautions you should follow:

- To properly install the lighting system, you must have a good understanding of automotive systems, along with proficiency in the installation and use of safety warning equipment.
- Do not install equipment or route wiring in the deployment path of an airbag.
- If a vehicle seat is temporarily removed, verify with the vehicle manufacturer if the seat needs to be recalibrated for proper airbag deployment.
- You should frequently inspect the light system to ensure that it is operating properly and that it is securely attached to the vehicle.
- When drilling into a vehicle structure, be sure that both sides of the surface are clear of anything that could be damaged.
- Refer to the instructions packed with related products for additional precautions and information.
- File these instructions in a safe place and refer to them when maintaining and/or reinstalling the product.
- Do not stare directly into the lights at a close range or permanent damage to your eyesight may occur.

Failure to follow all safety precautions and instructions may result in property damage, serious injury, or death.

## Mounting Bracket for MB1 Message Board

This publication has instructions for using the MBK01 Mounting Kit to mount the MB1 Message Board in the rear of the Ford® Interceptor Utility.

**NOTE:** For electrical installation instructions, refer to the Installation and Maintenance Instructions packed with the Message Board.

## Unpacking the Kit

After unpacking the kit, inspect it for damage that may have occurred in transit. If it has been damaged, do not attempt to install or operate it. File a claim immediately with the carrier, stating the extent of damage. Carefully check all envelopes, shipping labels, and tags before removing or destroying them. Ensure that the parts in the Kit Contents List are included in the package. Disposal of all shipping materials must be carried out in accordance with national and local codes and standards. If you are missing any parts, contact Customer Support at 1-800-264-3578, 7 a.m. to 5 p.m., Monday through Friday (CT).

Table 1 Kit contents

Qty.	Description	Part Number
2	Bracket Assy., Upper Mount,	857300075
2	Bracket, Lower Mount, MB1, FPIU	865201248
2	Screw, 1/4"-20, Hex Head	7002A000-12
4	Screw, #10 Type B, Pan, Six Lobe, Black	7011246-06
2	Washer, 1/4" Flat	7072A025

## Installing the Brackets

### ⚠ WARNING

**AIRBAG DEPLOYMENT:** Do not install equipment or route wiring in the deployment path of an airbag. Failure to observe this warning will reduce the effectiveness of the airbag or potentially dislodge the equipment, causing serious injury or death.

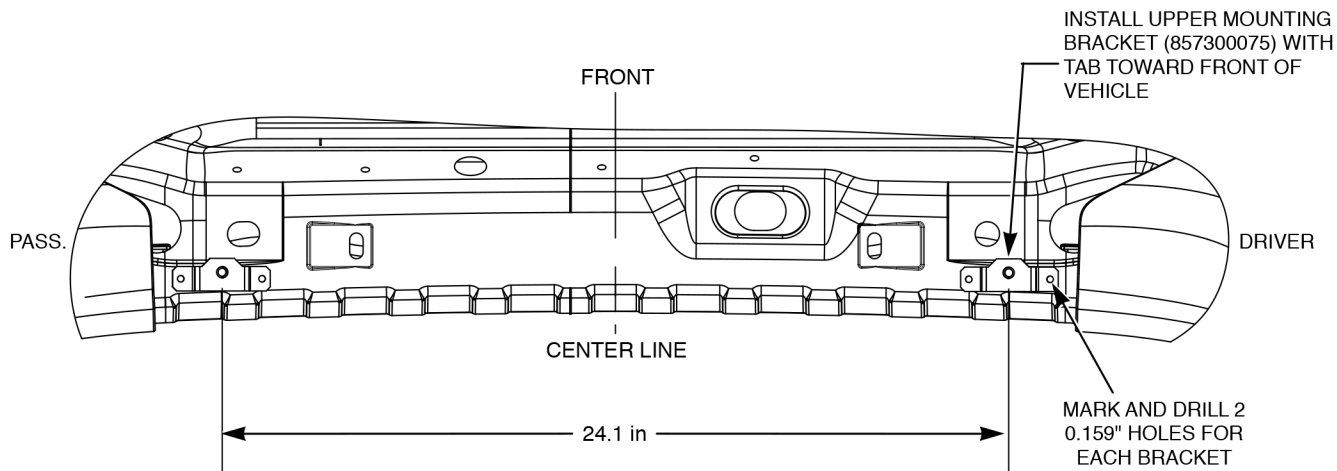
### NOTICE

**DRILLING PRECAUTION:** When drilling holes, check the area you are drilling into to be sure you do not damage vehicle components. All drilled holes should be deburred and all sharp edges should be smoothed. All wire routings going through drilled holes should be protected by a grommet or convolute/split loom tubing.

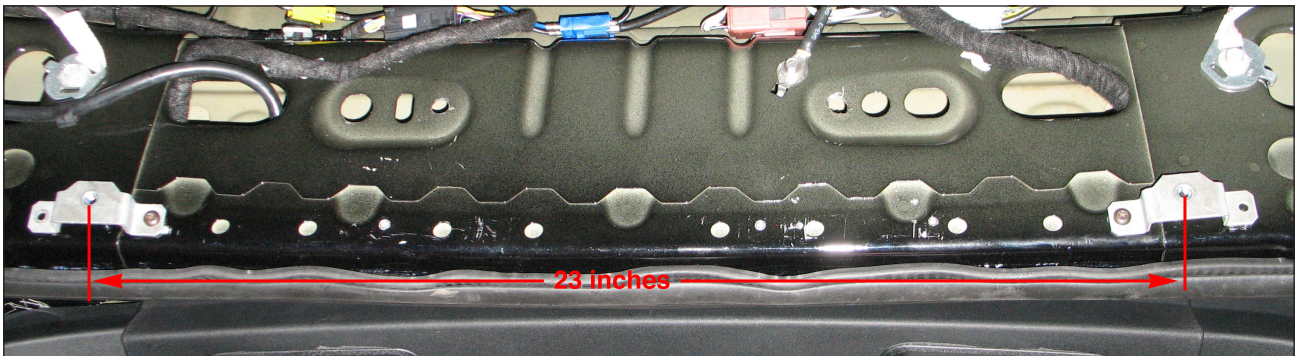
**IMPORTANT:** Plan all cable routing before the installation.

1. To access the rear roof support, disassemble the vehicle according to the manufacturer’s service manual.
2. Position the upper bracket assemblies as shown in Figure 1A for 2013 - 2019 vehicles, or Figure 1B for 2020 vehicles, and mark the holes.
3. Drill two 0.159-inch diameter (#21 drill) holes for each bracket.
4. Mount the brackets to the rear roof support with four #10 Type B screws and reinstall headliner.

Figure 1A Upper bracket assemblies secured on rear roof support (2013-2019)

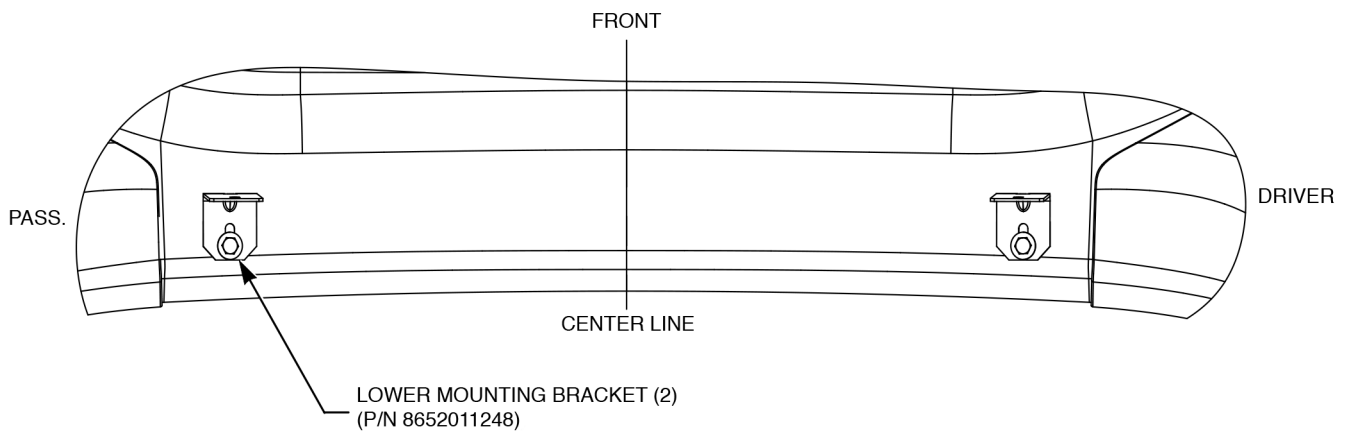


**Figure 1B** Upper bracket assemblies secured on rear roof support (2020)



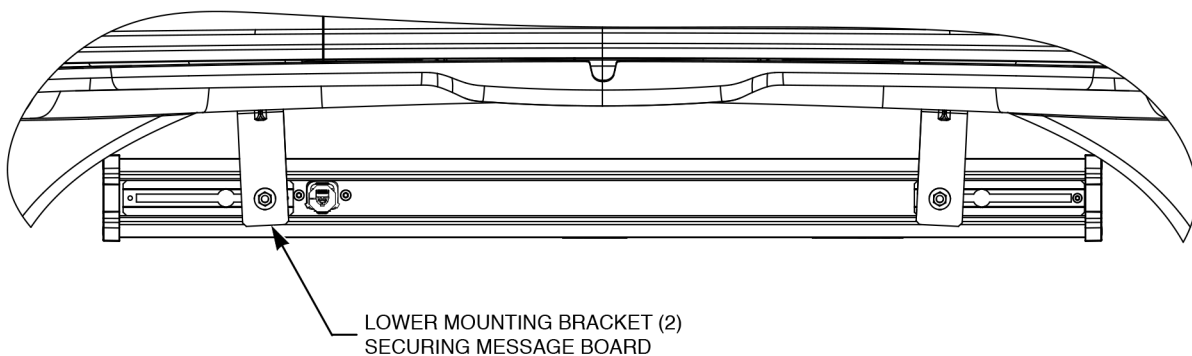
5. Locate the holes with a scratch awl in the upper bracket assemblies and pierce the headliner.

**Figure 2** Lower bracket assemblies positioned over rear headliner



6. Mount the lower brackets to the upper bracket assemblies with the 1/4"-20 cap screws and flat washers.
7. Mount the MB1 Message Board to the lower brackets with the hardware supplied with the Message Board.

**Figure 3** Message Board secured to lower mounting brackets (toward rear window)



8. Complete the installation according to the instructions provided with the Message Board.

**⚠ WARNING**

**LIGHT HAZARD:** *To be an effective warning device, an emergency warning system produces bright light that can be hazardous to your eyesight when viewed at a close range. Do not stare directly into the lights at a close range or permanent damage to your eyesight may occur.*

9. Test the Message Board for proper operation.

### **Getting Technical Support**

For technical support, please contact:

Federal Signal Corporation  
Service Department  
Phone: 1-800-433-9132  
Email: [empserviceinfo@fedsig.com](mailto:empserviceinfo@fedsig.com)

### **Getting Repair Service**

The Federal Signal factory provides technical assistance with any problems that cannot be handled locally. Any product returned to Federal Signal for service, inspection, or repair must be accompanied by a Return Material Authorization (RMA). Obtain a RMA from a local Distributor or Manufacturer's Representative. Provide a brief explanation of the service requested, or the nature of the malfunction.

Address all communications and shipments to the following:

Federal Signal Corporation  
Service Department  
2645 Federal Signal Dr.  
University Park, IL 60484-3167



**FEDERAL SIGNAL**  
Safety and Security Systems

2645 Federal Signal Drive  
University Park, Illinois 60484-3167

[www.fedsig.com](http://www.fedsig.com)

Customer Support  
Police/Fire-EMS: 800-264-3578 • +1 708 534-3400  
Work Truck: 800-824-0254 • +1 708 534-3400  
Technical Support: 800-433-9132 • +1 708 534-3400

© Copyright 2012-2019 Federal Signal Corporation

For Police Interceptor is a registered trademark of Ford Motor Company.  
All other product names or trademarks are properties of their respective owners.