

2562480 REV. A1 0920

## Safety Message to Installers of Warning Light Equipment

### **⚠ WARNING**

People's lives depend on your proper installation and servicing of Federal Signal products. It is important to read and follow all instructions shipped with this product and the original product. Listed below are some other important safety instructions and precautions you should follow:

- To properly install a light assembly, you must have a good understanding of automotive electrical procedures and systems, along with proficiency in the installation and use of safety warning equipment.
- If a vehicle seat is temporarily removed, verify with the vehicle manufacturer if the seat needs to be recalibrated for proper airbag deployment.
- When drilling into a vehicle structure, ensure that both sides of the surface are clear of anything that could be damaged.
- To be an effective warning device, this product produces bright light that can be hazardous to your eyesight when viewed at close range. Do not stare directly into this lighting product at close range, or permanent damage to your eyesight may occur.
- Frequently inspect the light system to ensure that it is operating properly and is securely attached to the vehicle.
- Refer to the instruction sheets included with related products for additional precautions and information.
- File these instructions in a safe place and refer to them when maintaining or reinstalling the product.

Failure to follow all safety precautions and instructions may result in property damage, serious injury, or death.

## Unpacking the Kit

After unpacking the kit, inspect it for damage that may have occurred in transit. If it has been damaged, do not attempt to install or operate it. File a claim immediately with the carrier, stating the extent of damage. Carefully check all envelopes, shipping labels, and tags before removing or destroying them. Ensure that the parts listed in Table 1 are included in the package. If you are missing any parts, contact Customer Support at 1-800-264-3578, 7 a.m. to 5 p.m., Monday through Friday (CT).

**Table 1 Kit contents**

Qty.	Description	Part Number
2	Bolt, Hex Hd., 5/16-18 x 1-3/4	7000469-28
2	Bolt, Hex Hd., 5/16-18 x 2-1/2	7000469-40
2	Bolt, Hex Hd., 5/16-18 x 3-1/2	7000469-56
2	Washer, Gutter Hook	8583491
2	Plate, Full Hex Bolt Keeper	8583492
6	Screw, #10 x 1/2" Thd. Frm. Phil., S.S., waxed	7011196-08

## Hook-Mounting Instructions for Federal Signal Light Bars

### Installing the Kit

Two 1-3/4-inch, 2-1/2-inch, and 3-1/2-inch bolts are supplied in the kit. If you need bolts of a different size when installing the light bar on vans, trucks, etc., order Federal Signal Model No. HK-BOLT. Use the length that best fits your vehicle. Vehicle-specific mounting hooks with the five-hole pattern are required for this installation.

#### **CAUTION**

**HEAVY OBJECT:** Use lifting aids and proper lifting techniques when removing or replacing this product. Failure to follow this warning may cause personal injury.

To install the kit:

1. Attach a gutter hook washer to a mounting hook (purchased separately) with a #10 pan head thread-forming screw. See Figure 1. Repeat the procedure with the other mounting hook.

**Figure 1 Gutter hook washer attached to mounting hook**

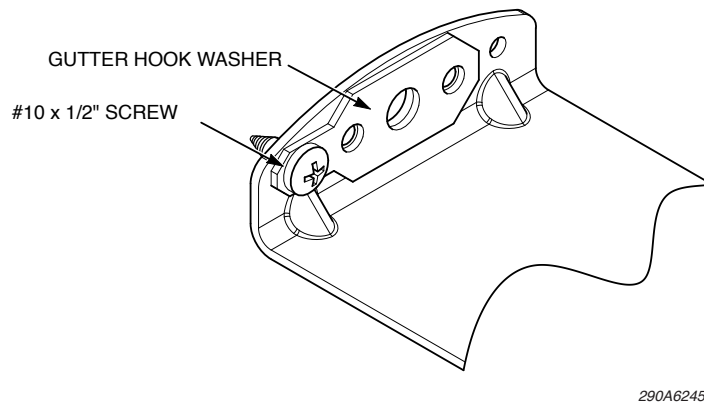

2. Place the light bar assembly on the vehicle roof. The assembly is usually centered over the B-pillar. Refer to the instructions included with the mounting system kit for additional information.
3. Fasten a mounting hook to each light bar mounting foot using the 1-3/4-inch, 2-1/2-inch, or 3-1/2-inch stainless steel hook-adjustment bolt and hand tighten the bolt. See Figure 2). Ensure that the mounting hooks do not interfere with the door or door glass.

**Figure 2 Full-Hex Keeper Plate secured to hook**

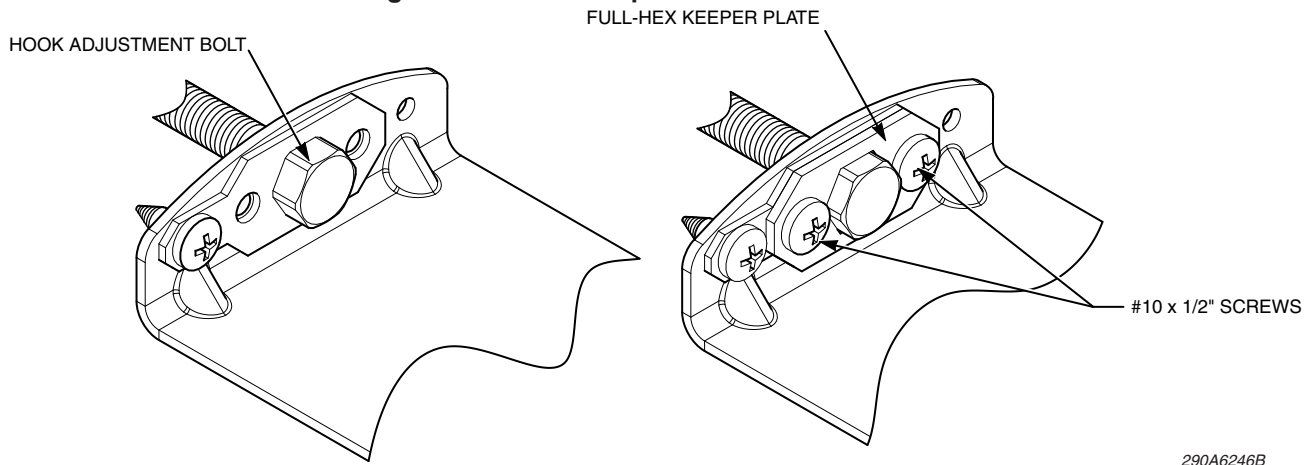

4. Evenly snug both adjustment bolts. Check to ensure that the light bar remains centered left to right on the vehicle roof.

**NOTICE**

**TORQUE ADJUSTMENT:** *Torque the adjustment bolts 6 ft-lb to 7 ft-lb and install keeper plates. Excessive tightening of the hook adjustment bolts can cause damage to the light bar, the mounting system, or the vehicle's roof.*

**⚠ CAUTION**

**ASSEMBLY WARNING:** *Ensure that the mounting kit is correct for the vehicle, and only use the supplied mounting kit hardware. If the mounting bracket is improperly assembled, the light assembly could fly off the vehicle causing injury or damage.*

5. Torque the adjustment bolts 6 ft-lb to 7 ft-lb, and install keeper plates.

**NOTE:** To allow the #10 thread-forming screws and keeper plates to be properly secured, the hex head of the hook-adjustment bolt should be oriented as shown in Figure 2.

6. After the light bar assembly is secured to the vehicle and the hook adjustment bolt is in the proper orientation, slide a full hex keeper plate over the hook adjustment bolt (Figure 2).
7. Secure the keeper plate with two #10 pan head thread-forming screws to prevent the hook adjustment bolt from rotating.
8. Repeat steps 4 and 5 with the other mounting foot.
9. For electrical installation instructions, refer to the installation and maintenance instructions included with the light bar.

**IMPORTANT:** Frequently inspect the lightbar to ensure that all fasteners and brackets are tight.

### **Ordering Replacement Parts**

To order replacement parts, please contact your local dealer/distributor or:

Customer Support  
Federal Signal Corporation  
Phone: 1-800-264-3578  
7 a.m. to 5 p.m., Monday through Friday (CT)

### **Getting Technical Support**

For technical support, please contact:

Federal Signal Corporation  
Service Department  
Phone: 1-800-433-9132  
Fax: 1-800-343-9706  
Email: emp-service-info@fedsig.com

## **Getting Repair Service**

The Federal Signal factory provides technical assistance with any problems that cannot be handled locally. Any product returned to Federal Signal for service, inspection, or repair must be accompanied by a Return Material Authorization (RMA). Obtain a RMA from a local Distributor or Manufacturer's Representative. Provide a brief explanation of the service requested, or the nature of the malfunction.

Address all communications and shipments to the following:

Federal Signal Corporation  
Service Department  
2645 Federal Signal Dr.  
University Park, IL 60484-3167

## **Limited Warranty**

This product is subject to and covered by a limited warranty, a copy of which can be found at [www.fedsig.com/SSG-Warranty](http://www.fedsig.com/SSG-Warranty). A copy of this limited warranty can also be obtained by written request to Federal Signal Corporation, 2645 Federal Signal Drive, University Park, IL 60484, email to [info@fedsig.com](mailto:info@fedsig.com) or call +1 708-534-3400.

This limited warranty is in lieu of all other warranties, express or implied, contractual or statutory, including, but not limited to the warranty of merchantability, warranty of fitness for a particular purpose and any warranty against failure of its essential purpose.



2645 Federal Signal Drive  
University Park, Illinois 60484-3167

[www.fedsig.com](http://www.fedsig.com)

Customer Support

Police/Fire-EMS: 800-264-3578 • +1 708 534-3400  
Work Truck: 800-824-0254 • +1 708 534-3400  
Technical Support: 800-433-9132 • +1 708 534-3400

© Copyright 2011-2020 Federal Signal Corporation

All product names or trademarks are property of their respective owners.