

25500821 A0 1122

Safety Messages for Installers of Warning Light Equipment

People's lives depend on your safe installation of our products. It is important to read, understand, and follow all instructions shipped with the products. Listed below are some other important safety instructions and precautions you should follow:

- To properly install the lighting and siren systems, you must have a good understanding of automotive systems, along with proficiency in the installation and use of safety warning equipment.
- Do not install equipment or route wiring in the deployment path of an airbag.
- If a vehicle seat is temporarily removed, verify with the vehicle manufacturer if the seat needs to be recalibrated for proper airbag deployment.
- Frequently inspect the light and siren systems to ensure that it is operating properly and that it is securely attached to the vehicle.
- When drilling into a vehicle structure, ensure that both sides of the surface are clear of anything that could be damaged.
- Refer to the instructions packed with related products for additional precautions and information.
- Do not stare directly into the lights at a close range, or permanent damage to your eyesight may occur.
- All effective sirens and horns produce loud sounds (120 dB) that may cause permanent hearing loss. Always minimize your exposure to the sound of the siren and horn and wear hearing protection. Do not sound the siren and horn indoors or in enclosed areas where you and others will be exposed to the sound.
- File these instructions in a safe place and refer to them when maintaining and/or reinstalling the product.

Failure to follow all safety precautions and instructions may result in property damage, serious injury, or death.

Product Overview

This publication has instructions for using the Model ESB2-SIL22ND bracket kit to mount the ES100C, or Model ESBL2-SIL22ND bracket kit to mount the ES100C and/or MicroPulse MPS6U, MPS600, MPS600U, MPS12U, MPS1200, MPS1200U, and MPSW9 lights in the grille of the 2022 Silverado 1500.

NOTE: For electrical installation instructions, refer to the Installation and Maintenance Instructions included with the siren and light head.

Unpacking the Kit

After unpacking the kit, inspect it for damage that may have occurred in transit. If it has been damaged, do not attempt to install or operate it. File a claim immediately with the carrier, stating the extent of the damage. Carefully check all envelopes, shipping labels, and tags before removing or destroying them. Ensure that the parts in Table 1 are included in the package. If you are missing any parts, contact Customer Support at 1-800-264-3578, 7 a.m. to 5 p.m., Monday through Friday (CT).

Table 1 Kit contents

Qty	Description	Part Number
1	2022 Silverado® Dual-Bracket ES100C	856703175
1	1/4-20 Black Steel Head Phillips® Machine Screw	7000547A-16
1	1/4-20 Steel Hex Head Nylon Insert Nut	7058A009
4	#6-32 Stainless Steel Pan Head Phillips Machine Screw	7000491-08
4	#6-32 Stainless Steel Hex Head External Keps® Nut	7058A046

Installing the Brackets

⚠ WARNING

AIRBAG DEPLOYMENT: Do not install equipment or route wiring in the deployment path of an airbag. Failure to observe this warning will reduce the effectiveness of the airbag or potentially dislodge the equipment, causing serious injury or death.

IMPORTANT: Plan all cable routing before the installation.

NOTICE

THREAD DAMAGE AND GALLING: To prevent thread damage and galling, use anti-seize lubricant on all stainless steel fasteners.

Installing the ESBL2-SIL22ND Bracket

To install the speaker and lights:

1. Remove the vehicle’s front fascia according to the vehicle manufacturer’s instructions.
2. Install the speaker bracket to bolts on the vehicle as shown in Figure 1.

Figure 1 Insert Bracket Assembly
BOLT LOCATIONS

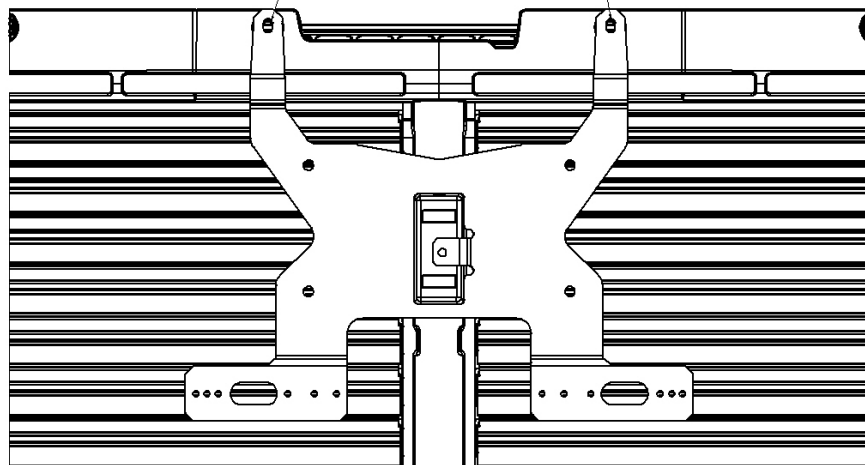

NOTICE

DRILLING PRECAUTION: When drilling holes, check the area you are drilling into to be sure you do not damage vehicle components. All drilled holes should be deburred, and all sharp edges should be smoothed. All wire routings going through drilled holes should be protected by a grommet or convolute/split loom tubing.

3. Using the hole in the center of the bracket as a template, drill a 1/4-inch hole in the plastic center post. Install the supplied 1/4-inch screw and nut through the previously drilled hole
4. Install the speakers to the speaker bracket and light head using the 5/16-inch hardware supplied with the speaker. See Figure 2.

Figure 2 ESBL-SIL22ND Bracket (Dual speaker installation shown)

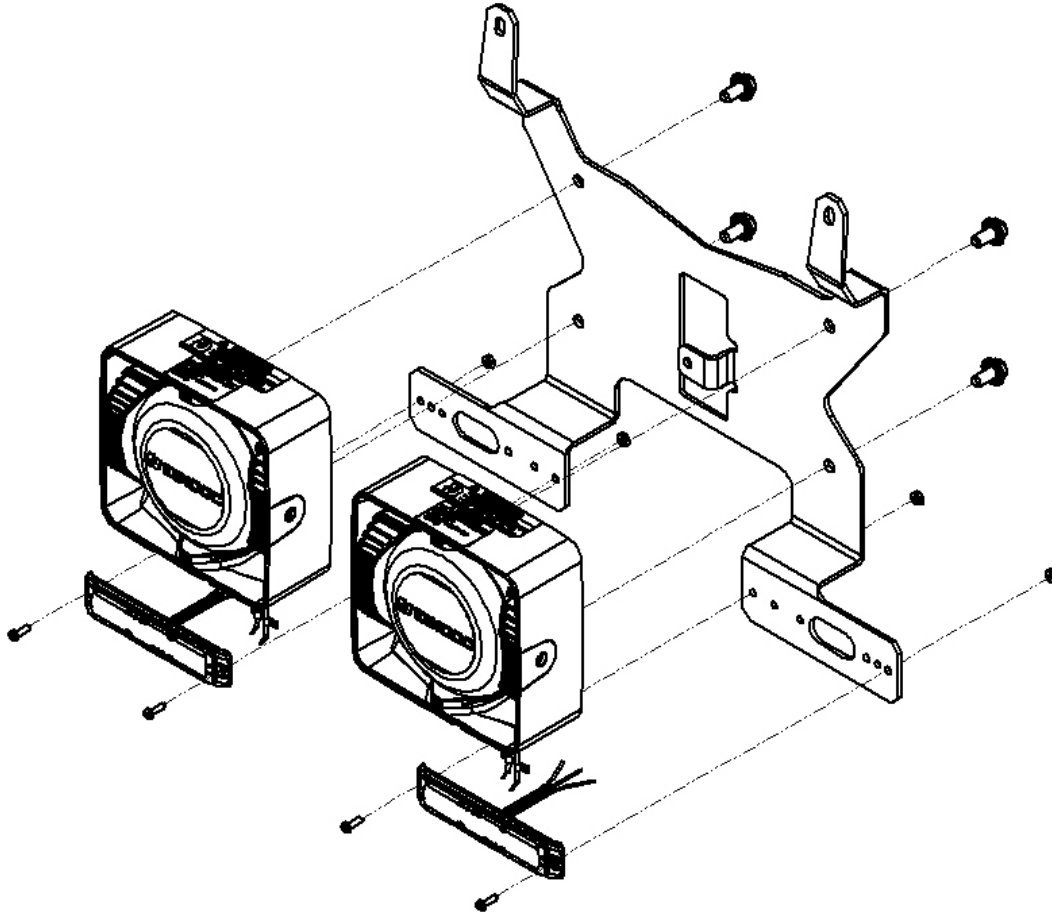

5. Install the light heads to the speaker brackets using the #6-32 screws and Keps® nuts supplied with this kit.
6. Complete the wiring as indicated by the speaker and light head instruction manuals.
7. Install the front fascia according to the vehicle manufacturer's instructions.
8. Test the lights and speakers for proper operation.

⚠ WARNING

SOUND HAZARD: All effective sirens and horns produce loud sounds (120 dB) that may cause permanent hearing loss. Always minimize your exposure to siren sounds and wear hearing protection. Do not sound the siren indoors or in enclosed areas where you and others will be exposed to the sound.

Getting Technical Support and Service

For technical support and service, please contact:

Service Department
Federal Signal Corporation
Phone: 1-800-433-9132
Email: empserviceinfo@fedsig.com
www.fedsig.com

Getting Repair Service

The Federal Signal factory provides technical assistance with any problems that cannot be handled locally.

Any units returned to Federal Signal for service, inspection, or repair must be accompanied by a Return Material Authorization (RMA). Obtain an RMA from a local Distributor or Manufacturer's Representative.

Provide a brief explanation of the service requested or the nature of the malfunction.

Address all communications and shipments to the following:

Federal Signal Corporation
Service Department
2645 Federal Signal Drive
University Park, IL 60484-3167

Ordering Replacement Parts

To order replacement parts, call Customer Support at 1-800-264-3578, 7 a.m. to 5 p.m., Monday through Friday (CT), or contact your nearest distributor.

Limited Warranty

This product is subject to and covered by a limited warranty, a copy of which can be found at www.fedsig.com/SSG-Warranty. A copy of this limited warranty can also be obtained by written request to Federal Signal Corporation, 2645 Federal Signal Drive, University Park, IL 60484, email to info@fedsig.com or call +1 708-534-3400.

This limited warranty is in lieu of all other warranties, express or implied, contractual or statutory, including, but not limited to the warranty of merchantability, warranty of fitness for a particular purpose and any warranty against failure of its essential purpose.



FEDERAL SIGNAL
Safety and Security Systems

2645 Federal Signal Drive
University Park, Illinois 60484-3167

www.fedsig.com

Customer Support

Police/Fire-EMS: 800-264-3578 • +1 708 534-3400

Work Truck: 800-824-0254 • +1 708 534-3400

Technical Support: 800-433-9132 • +1 708 534-3400

© Copyright 2022 Federal Signal Corporation

All product names or trademarks are properties of their respective owners.